

EDF R&D



FLUID DYNAMICS, POWER GENERATION AND ENVIRONMENT DEPARTMENT
SINGLE PHASE THERMAL-HYDRAULICS GROUP

6, QUAI WATIER
F-78401 CHATOU CEDEX

TEL: 33 1 30 87 75 40
FAX: 33 1 30 87 79 16

MARCH 2024

code_saturne documentation

**code_saturne version 8.0 tutorial:
Turbulence simulation in a mixing tee**

contact: saturne-support@edf.fr



TABLE OF CONTENTS

	I Introduction	5
1	Tutorial components	6
2	Tutorial structure	6
3	What you will learn	6
	II Part 1 - Vattenfall T-Junction Benchmarking Experiment	7
1	Case description	8
2	Test rig dimensions	8
3	Flow physics	9
4	Operating conditions	9
5	Fluid properties	9
5.1	GEOMETRY	10
5.2	BOUNDARY CONDITIONS	10
6	Creating the code_saturne Study and Cases	10
	III Part 2 - RANS Computation	12
1	What you will learn	13
2	Setting up the CFD simulation	13
2.1	SELECTING THE VOLUME MESH	13
2.2	CALCULATION FEATURES	15
2.3	VOLUME CONDITIONS	15
2.4	BOUNDARY CONDITIONS	18
2.5	TIME SETTINGS	20
2.6	NUMERICAL PARAMETERS	20
2.7	POSTPROCESSING	21
3	Running and analysing the simulation	22
3.1	RUNNING THE SIMULATION	22
4	Results analysis	23
4.1	IMPORTING CODE_SATURNE RESULTS INTO SALOME/PARAVIS	23
4.2	CHECKING THE Y+ AT THE BOUNDARIES	24

4.3	VISUALISING DATA ON A SLICE PLANE	25
4.4	EXTRACTING LINE DATA	26

IV Part 3 - Comparison of Predicted and Experimental Data **29**

1	Comparison of the axial velocity with the experimental data.	30
1.1	COMPARISON ALONG HORIZONTAL LINES.	30
1.2	COMPARISON ALONG VERTICAL LINES	32
2	Comparison the dimensionless temperature with the experimental data	34

V Part 4 - LES Computation **36**

1	What you will learn	37
1.1	CREATE A CASE WITH “COPY-FROM” FEATURE	37
1.2	SETTING UP THE CFD SIMULATION	37
1.3	MESH TAB	37
1.4	CALCULATION FEATURES	37
1.5	TIME SETTINGS	37
2	Programming LES inflow boundary conditions with user coding	38
3	Running and analysing the simulation for 3s of physical time	38
4	Setting the simulation for 8s of physical time	39
4.1	TIME SETTINGS	39
4.2	POSTPROCESSING TAB - TIME AVERAGES	40
5	Running and analysing the simulation for 8s of physical time	42
6	Results Analysis	42

VI References **43**

1	References	44
----------	-----------------------------	-----------

VII Appendix **45**

1	Appendix A – Experimental Data from [4]	46
2	Appendix B – Script SALOME.	54
3	Appendix C – Creating the Computational Domain	110
4	What you will learn	110
5	Creating the Geometry	110
6	Creating groups	112
6.1	CREATING GROUPS OF FACES	112
6.2	CREATING GROUP OF EDGES	114
7	Meshing	117

7.1	CREATING GROUPS IN MESH	121
7.2	EXTRUSION	123

Chapter I

Introduction

1 Tutorial components

This tutorial makes use of:

- The SALOME [1] platform for geometry generation, meshing, and post-processing
- code_saturne [2], [3] for CFD calculations
- Reference [4] for comparison with published results

To work through this tutorial you will need a computer on which these two software applications are already available or on which you have permission to install them.

2 Tutorial structure

In PWR plants, thermal fatigue can occur in energy cooling systems which are subjected to cyclic stresses. These cyclic stresses are generally found in T-Junctions where cold and hot water streams mix and the resulting turbulent fluctuations create thermal fluctuations at the walls which can lead to thermal fatigue.

This tutorial focuses on modelling such a T-Junction, using the RANS and the LES approach and is composed of five complementary parts:

- Part 1 (Section II) presents the T-Junction case experimental set-up.
- Part 2 (Section III) shows how to set-up the RANS case in code_saturne and the results of the RANS simulation compared with experimental data [4].
- Part 3 (Section IV) presents the results of the RANS simulation and compares them with experimental data.
- Part 4 (Section V) describes how to set-up a LES case.
- Appendix VII provide experimental datas; SALOME script to automatically create the mesh; useful information to generate the geometry and the mesh

3 What you will learn

Through this tutorial, you will learn how to:

- Setup an unsteady, viscous, turbulent, CFD simulation with variable fluid properties and no-slip walls, using code_saturne
- Program user coding to:
 - Compute user defined variables and extract quantities of interest for post-processing
 - Model the inlet turbulence for the LES computation using the Synthetic Eddy Method
 - Compute the time averages of variables for the LES simulation
- Control and run the code_saturne simulations from the CFDStudy module
- Examine the code_saturne output and results files, including data along specified profiles and at monitoring points
- Visually and quantitatively compare the predicted results with experimental data
- Additionnal tips to create a computational domain and a hexahedral mesh for a T-junction with SALOME.

Chapter II

Part 1 - Vattenfall T-Junction Benchmarking Experiment

1 Case description

The OECD/NEA-Vattenfall T-Junction benchmark [4] was initiated to test the ability of state-of-the-art CFD codes to predict the important parameters affecting high-cycle thermal fatigue in mixing tees or T-Junctions. The experiments were carried out at the Älvkarleby Laboratory at the Vattenfall R&D facility in Sweden.

The test rig used to complete the experiments is made from Plexiglas® and consists of two main pipe sections mounted horizontally upstream and downstream of a T-Junction with a branch pipe mounted vertically above this junction. This set-up is illustrated in Figure II.1.

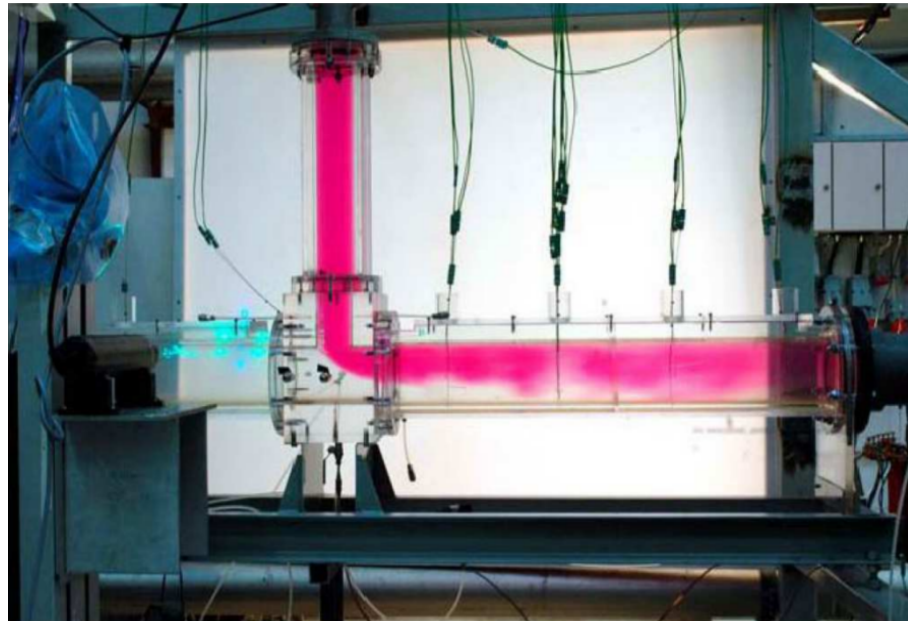

Figure II.1: Photograph of the Vattenfall test section [4].

The working fluid is deionised tap water with cold water flowing in the main horizontal pipe which is fed via a long inlet pipe from a high level reservoir. Hot water is pumped into the vertical pipe via a shorter inlet section and the two fluid streams mix in and downstream of the T-Junction.

The test rig dimensions are described next.

2 Test rig dimensions

The horizontal and vertical pipes in the experiment have differing diameters and lengths. The horizontal pipes upstream and downstream of the T-Junction have an internal diameter of 140mm and a length of 1070mm. The vertical pipe has an internal diameter of 100mm and a length of 470mm. These dimensions, as well as those of the T-Junction, are shown in Figure II.2.

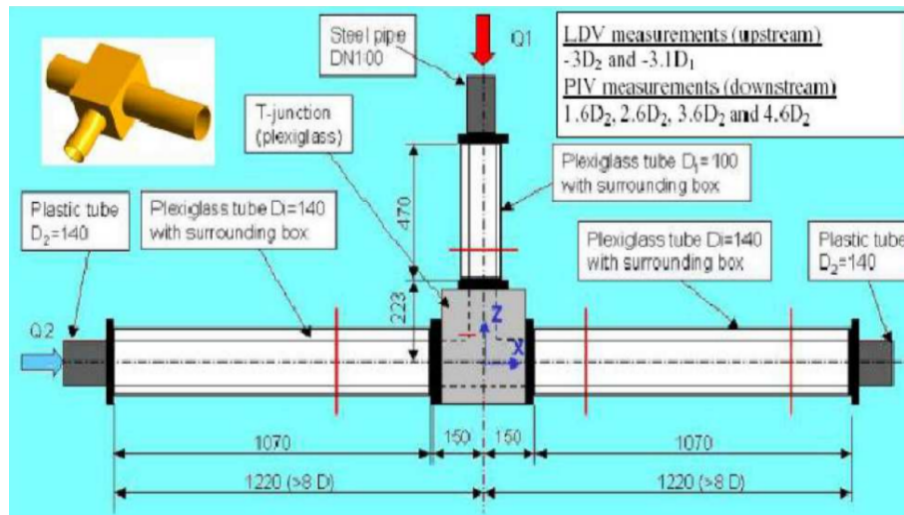

Figure II.2: Schematic of the mixing Tee in Plexiglas [4].

The flow physics are described next.

3 Flow physics

The flow physics involve the mixing of hot and cold fluid streams in a T-junction. As can be seen in Figure II.1, the flow field is steady in the pipes upstream of the T-junction but unsteady downstream of the meeting point of the hot and cold streams due to the mixing process of the two streams. The mixing process produces complex flow patterns, with non-uniform temperatures that will have an impact on local wall temperatures. The dominant physics is forced convection with unsteady mixing in and downstream of the T-junction.

The test rig operating conditions are described next.

4 Operating conditions

The test rig operating conditions are as follows:

- The cold water is entering the test section at a temperature of 19.0°C and with a velocity $\vec{U} = (0.585, 0.0, 0.0)$
- The hot water is entering the test section with a temperature of 36.0°C and with a velocity $\vec{U} = (0.0, 0.0, -0.764)$

The fluid properties are described next.

5 Fluid properties

The difference in temperature between the cold and hot water streams is approximately 17°C . This temperature difference is sufficient to result in property variations in the fluid streams. Table II.1 presents the approximate temperature dependence of the fluid properties of water [4].

$T(^{\circ}C)$	$\rho(kg/m^3)$	$k(W/mK)$	$\mu(PA.s)$	$C_p(J/kg.K)$	$Pr(-)$
15	999.2	0.5911	1.1380×10^{-3}	4186	8.058
20	998.3	0.5996	1.0020×10^{-3}	4182	6.988
25	997.2	0.6076	0.8904×10^{-3}	4179	6.125
30	995.8	0.6151	0.7977×10^{-3}	4178	5.419
35	994.1	0.6221	0.7196×10^{-3}	4178	4.833
40	992.3	0.6287	0.6533×10^{-3}	4178	4.342

Table II.1: Variation of water properties with temperature.

5.1 Geometry

The schematic of the computational domain is presented in Figure II.3 below.

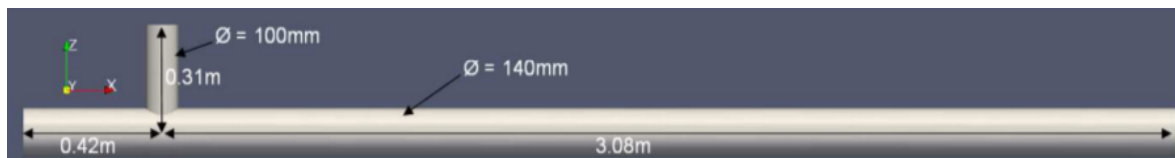

Figure II.3: Schematic of the mixing Tee.

As per the experimental setup, the horizontal pipe has a diameter of 140mm and the vertical pipe a diameter of 100mm. The reference frame is located at the cross section of the two pipes. The cold and the hot inlets are respectively located at -0.42m and 0.31m from this reference frame. The outlet is situated at 3.5m from the cold inlet.

5.2 Boundary conditions

Four boundary conditions are used in this study:

- Cold inlet : $\vec{U} = (0.585, 0.0, 0.0)$ with a temperature of $19.0^{\circ}C$
- Hot inlet : $\vec{U} = (0.0, 0.0, -0.764)$ with a temperature of $36.0^{\circ}C$
- Outlet : The standard outlet condition is used
- Walls : The wall boundary are assumed to be no-slip, smooth and adiabatic

6 Creating the code_saturne Study and Cases

A code_saturne study called *Mixing_Tee* and two cases are created. One for the first set of calculations, which we call *RANS*, and the other for the LES simulation, which we call *LES*.

The study and the first case are created using the procedure described in Part I of tutorial 1 [5]. The second case will be created later as a copy of the first one. Start SALOME with the command `code_saturne salome`, select the CFDStudy module, and go through all the steps detailed in [5] to:

- Create the CFD case structure with the CFDStudy module
- Save the new file as 'Mixing_Tee'
- Customise the background settings

Once the study and the case have been created, you should end up with the directory structure (Figure II.4) shown in the Object Browser tab, displaying the study and the first case.

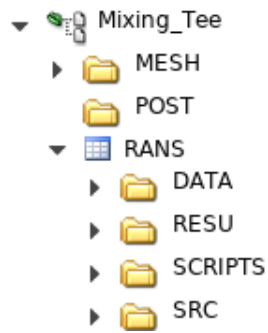

Figure II.4: *Mixing_Tee* Study and *RANS* case File Structure

The case is then ready to be set up.

Chapter III

Part 2 - RANS Computation

1 What you will learn

In this second part of the tutorial you will learn how to set-up, run and post-process the results of a steady-state RANS calculation for the T-Junction generated in Appendix (3). The setting up and running will be completed using the code_saturne GUI. Post-processing will be undertaken using ParaViS in SALOME where you will learn how to generate section plots in the flow domain and generate 2D line plots in order to compare predicted with experimental data.

2 Setting up the CFD simulation

The CFD case is set-up and run from code_saturne but it can also be set with CFDStudy module (Section II). In the CFDStudy module, create a ‘New File’ and verify that the case directory structure has been correctly recognised by clicking on the ‘Identity and Paths’ section in the tree menu. If the case directory is correct you can continue. If not, you will need to set the correct directory. Then, save the file. The default name is ‘setup.xml’. You can now proceed with setting up the case, following the top down order of the sections in the left-hand column, starting with the mesh.

2.1 Selecting the volume mesh

Open the ‘MESH’ section and add the ‘T_junction_RANS_07042016_602712.med’ to the initially empty list of meshes (Figure III.1). This is done by clicking on the “+” icon shown in Figure III.1 and selecting the appropriate mesh in the MESH directory.

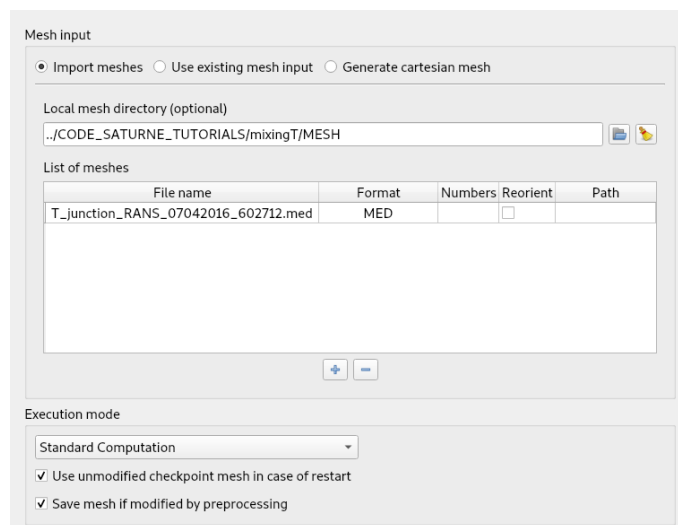

Figure III.1: Selecting the ‘T_junction_RANS_07042016_602712.med’ file for the calculations.

Boundary zones Four boundary conditions are used in this study:

- Cold inlet : $U (0.585, 0.0, 0.0)$ with a temperature of $19.0^{\circ}C$
- Hot inlet : $U (0.0, 0.0, -0.764)$ with a temperature of $36.0^{\circ}C$
- Outlet : The standard outlet condition is used
- Walls : The wall boundary are assumed to be no-slip, smooth and adiabatic

For the LES computation, the Synthetic Eddy Method [8] is used to artificially generate turbulence at the domain inlets.

Two methods may be used to specify the boundary conditions. The user can create them manually or they can be partially completed by code_saturne itself.

For the first method, in the ‘Boundary zones’ section, and in its panel click on the ‘add’ button four times to manually create the four boundary conditions generated in Phase II, namely ‘inlet_1’, ‘inlet_2’, ‘outlet’ and ‘wall’. Change the ‘Selection criteria’ name of each boundary to reflect exactly the name of groups defined in Phase II. Then, change the nature to ‘inlet’ in the ‘Nature’ drop-down menu for ‘inlet_1’ and ‘inlet_2’, the nature to ‘outlet’ for the boundary ‘outlet’ and leave the nature ‘wall’ for the boundary ‘walls’. The boundary regions are now fully defined (Figure III.2).

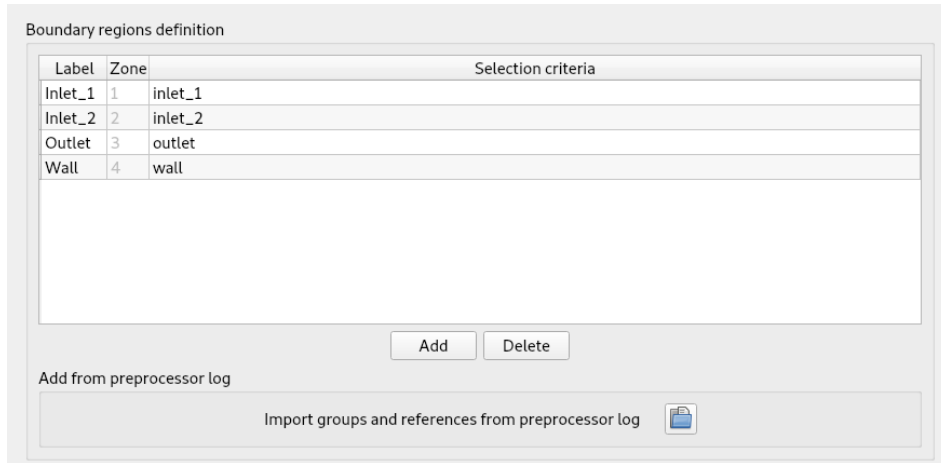

Figure III.2: Boundary definition.

For the second method, execute a ‘Mesh quality criteria only’ calculation from the ‘MESH’ section as shown in the tutorial 1 Part II [5]. Then, go back into the ‘Boundary zones’ section and click on the icon in the panel to import groups and references from the pre-processor log file called ‘preprocessor.log’ as shown in Figure III.3 and click on ‘Open’.

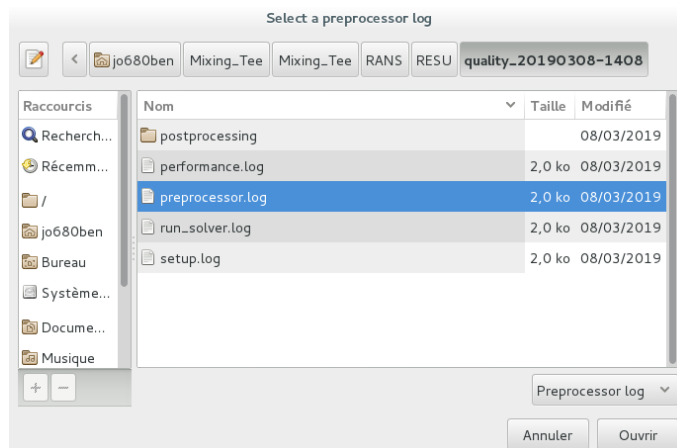

Figure III.3: Preprocessor listing for boundary definitions.

You can now go to the ‘Calculation features’ section in order to specify the flow physics for the calculation.

2.2 Calculation features

In the 'Calculation features' section, leave all the default values unchanged: multiphase flow, atmospheric flows, combustion and the electrical and compressible models are all inactive.

Turbulence models You need to change 'Turbulence model' to 'k-epsilon Linear Production'. In the 'Advanced Options' sub-section, ensure that the wall function type is set to 'Two scale model' and that 'Gravity terms in the turbulence equations' is selected.

Thermal model Activate 'Temperature (Celsius)' under 'Thermal scalar' option. This will activate the solution of the temperature equation and designate Temperature as the scalar specified at the boundary conditions (Figure III.4).

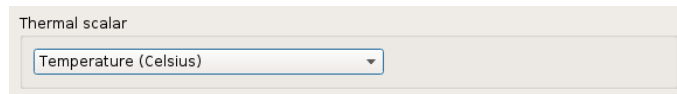

Figure III.4: Activating solution of the Temperature equation

Body forces Set the acceleration of gravity by entering the value ' $-9.81m/s^2$ ' for its component in the vertical (Z) direction in the 'Gravity' panel, Figure III.5.

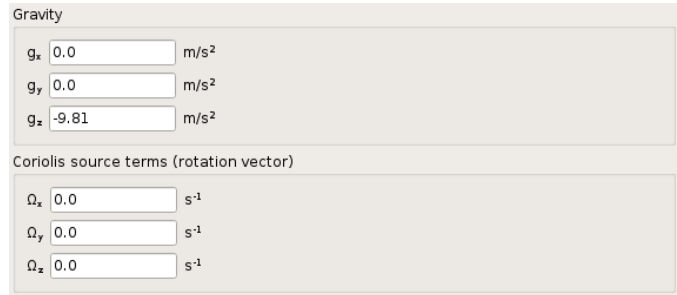

Figure III.5: Gravity and Hydrostatic pressure specification.

You can now move to the 'Fluid properties' section.

2.3 Volume conditions

Due to the mixing of the hot and cold fluid streams, all the physical properties of the fluid are temperature dependant. The fluid is water at atmospheric pressure where the density, viscosity, specific heat and thermal conductivity are considered as function of the local temperature using the following relations [7]:

$$C_p(T) = -1.0224 \times 10^{-4}T^3 + 2.9201 \times 10^{-2}T^2 - 1.822T + 4209.9 \quad (\text{III.1})$$

$$\mu(T) = -1.9296 \times 10^{-9}T^3 + 4.7256 \times 10^{-7}T^2 - 4.2088 \times 10^{-5}T + 1.6947 \times 10^{-3} \quad (\text{III.2})$$

$$\frac{\lambda}{C_p(T)} = -3.0374 \times 10^{-13}T^3 - 2.1701 \times 10^{-9}T^2 + 4.7970 \times 10^{-7}T + 1.3538 \times 10^{-4} \quad (\text{III.3})$$

$$\rho(T) = 1.4078 \times 10^{-5}T^3 - 5.5855 \times 10^{-3}T^2 - 2.8886 \times 10^{-3}T + 1000.4 \quad (\text{III.4})$$

Physical properties For this tutorial, these physical properties are coded in GUI. Initialise all parameters corresponding to the intermediate temperature 27.5°C and set the option "user law" for all the quantities which will be calculated with the set of equations defined above. The final set-up for this panel is shown in Figure III.6.

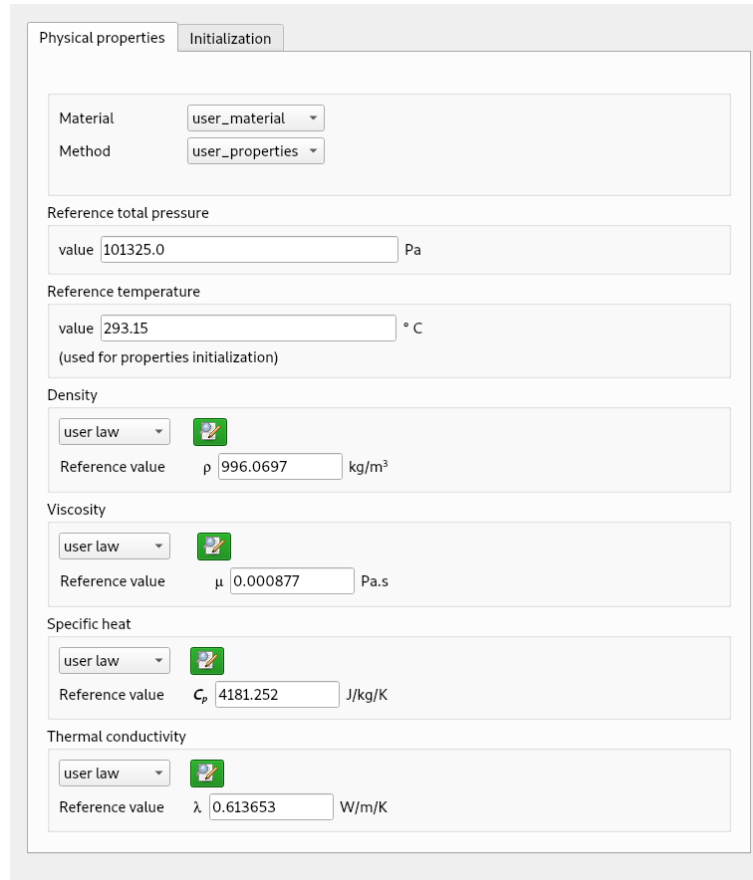

Figure III.6: Selection of fluid properties.

The implementation of the different laws for the properties are shown in Figure III.7 to Figure III.10.

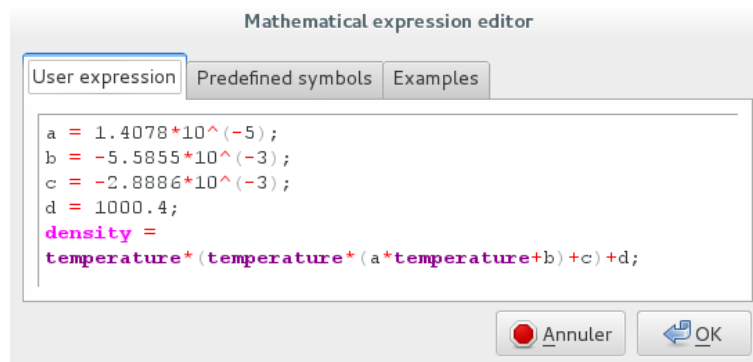

Figure III.7: Coding the density as a function of the temperature.

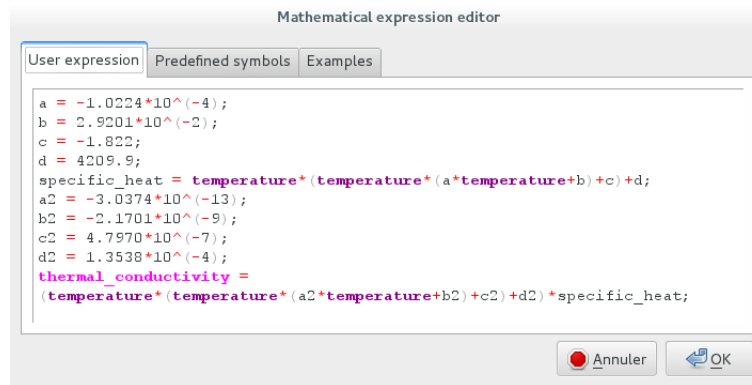

Figure III.8: Coding the thermal conductivity as a function of the temperature.

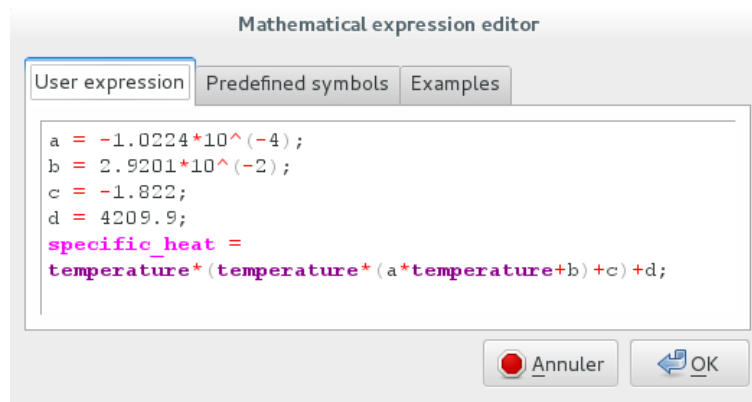

Figure III.9: Coding the specific heat as a function of the temperature.

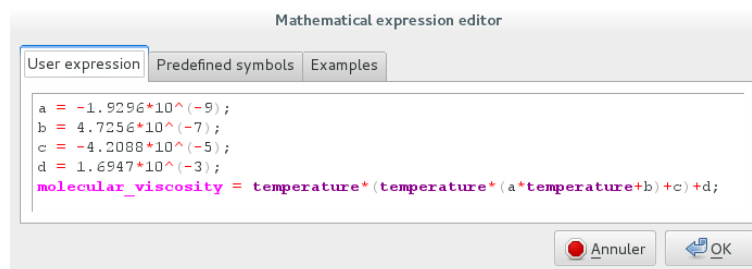

Figure III.10: Coding the viscosity as a function of the temperature.

In the 'Reference values' sub-section, set the reference pressure to 101325.0Pa and the reference velocity to 0.5m/s.

No other settings are required in this section.

Initialization The initial values for the velocity and temperature are defined in the 'Initialization' sub-section of the 'Volume zones' section III.11. The flow is initially stagnant by default. To set the initial temperature, click on the 'Mathematical Expression Editor' button marked 'Thermal' in the 'Initialization' panel and enter the temperature of the cold inlet in the pop-up editor panel (Figure III.12).

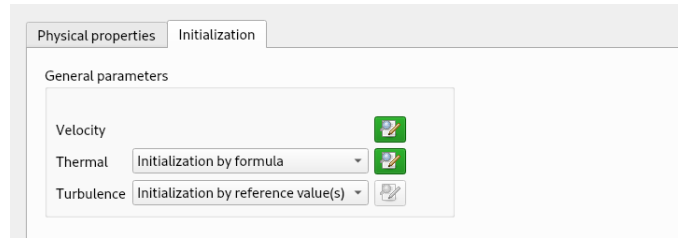

Figure III.11: Initialiaziation.

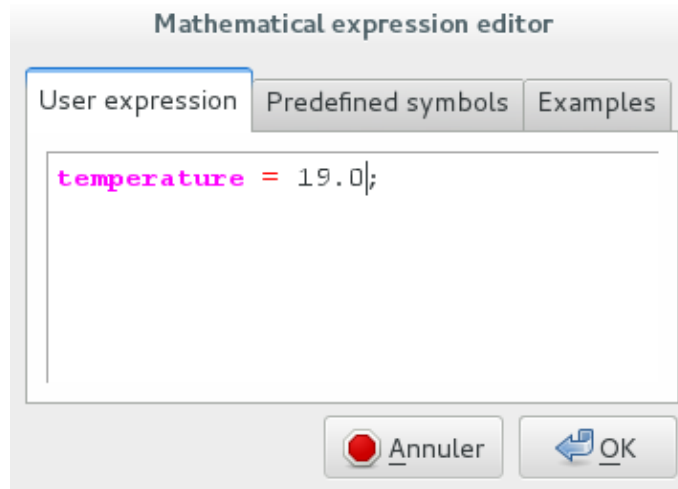

Figure III.12: Initial temperature specification.

No other settings are required in this section. You can now move to the 'Boundary zones' section.

2.4 Boundary conditions

Change the nature of each boundary condition as explained above in order to obtain an identical boundary set-up to that shown in Figure III.2.

Having defined their type, the boundary values can now be specified. Select the 'Boundary conditions' sub-section and click on the boundary 'inlet_1'. Specify all boundary values as given in Figure III.14. Boundary values for 'inlet_2' are presented in the Figure III.16.

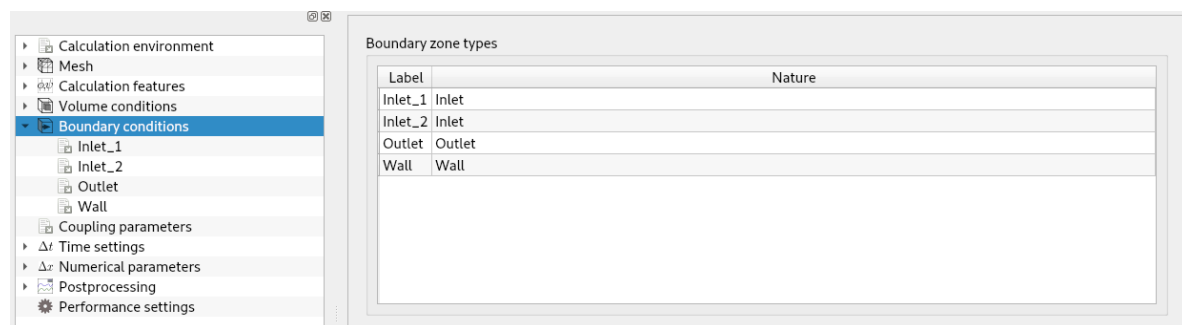

Figure III.13: Boundary Conditions Nature

BC_1 [Inlet]

Convective Inlet

Mapped Inlet

Velocity

norm 0.585 m/s

Direction user profile

Turbulence

Calculation by hydraulic diameter

Hydraulic diameter 0.14 m

Thermal

temperature

Type Prescribed value

Value 19

Figure III.14: Inlet_1

BC_2 [Inlet]

Convective Inlet

Mapped Inlet

Velocity

norm 0.764 m/s

Direction normal direction to the inlet

Turbulence

Calculation by hydraulic diameter

Hydraulic diameter 0.1 m

Thermal

temperature

Type Prescribed value

Value 36

Figure III.15: Inlet_2

Leave the default parameters for the 'outlet' and 'walls' boundary conditions.

No other settings are required in this section. You can now go to the 'Numerical parameters' section.

2.5 Time settings

In the ‘Time Settings’ section, choose Steady option, keep default values except for iterations number. Set it to 3,000.

The screenshot shows the 'Time Settings' panel with the following values:

- Time step option: Steady (local time step)
- Velocity-Pressure algorithm: SIMPLEC
- Reference time step: 0.1 s
- Maximal CFL number: 1.0
- Maximal Fourier number: 10.0
- Minimal time step factor: 0.1
- Maximal time step factor: 1000.0
- Time step maximal variation: 0.1
- Stopping criterion: Number of time steps
- Stopping value: 3000

Figure III.16: Time Settings

No other settings are required in this section. You can now move to the ‘Postprocessing’ section.

2.6 Numerical Parameters

In the ‘Numerical Parameters’ section leave as default all settings.

Equation parameters In the ‘Equation parameters’ sub-section, the ‘Solver’ panel shows that pressure, velocity and temperature are solved for. In order to decrease overall computation time, it is possible to decrease the solver precision to 10^{-5} as shown in Figure III.17.

Name	Solver Choice	Preconditioning Choice	Solver Precision	Verbosity
pressure	Automatic	Automatic	1e-05	0
velocity	Automatic	Automatic	1e-05	0
k	Automatic	Automatic	1e-05	0
epsilon	Automatic	Automatic	1e-05	0
temperature	Automatic	Automatic	1e-05	0

Figure III.17: Solver parameters.

Leave as default the parameters in the ‘Scheme’ panel. However, if you have limited computational resources, you can change the second Centered scheme to the first order Upwind scheme for the convective variables.

The ‘Clipping’ panel is used to set the temperature bounds thereby making it possible to instruct the code to clip the temperature to these values if it strays outside this defined range. This is done in order to help improve solution stability. For this tutorial you can enter the cold and hot inlet temperature for clipping the predicted scalar temperature, as shown in Figure III.18.

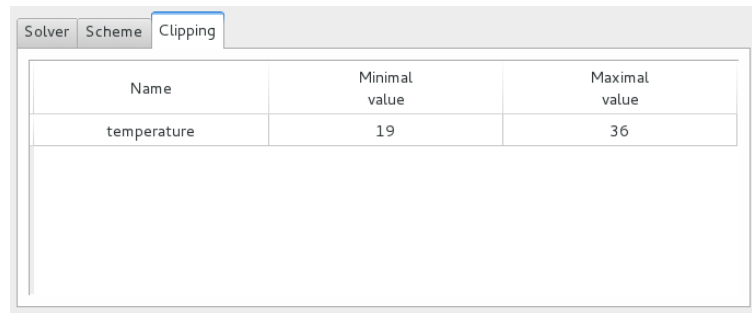

Name	Minimal value	Maximal value
temperature	19	36

Figure III.18: Clip of the scalar temperature.

2.7 Postprocessing

In the 'Postprocessing' section, go into the 'Monitoring Points' panel. Click on the '+' icon to add a probe then enter the coordinate of this first probe as shown in Figure III.19. Repeat this procedure for other probes of your own choice. Monitoring probes can be useful to check the convergence of the simulation.

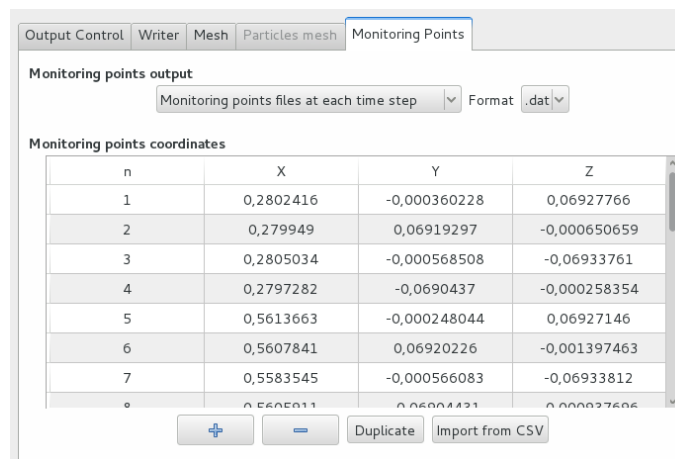

n	X	Y	Z
1	0,2802416	-0,000360228	0,06927766
2	0,279949	0,06919297	-0,000650659
3	0,2805034	-0,000568508	-0,06933761
4	0,2797282	-0,0690437	-0,000258354
5	0,5613663	-0,000248044	0,06927146
6	0,5607841	0,06920226	-0,001397463
7	0,5583545	-0,000566083	-0,06933812

Figure III.19: Monitoring points.

The code_saturne calculation is now fully specified from the standpoint of the GUI and the xml file should be saved.

3 Running and analysing the simulation

3.1 Running the simulation

In the ‘Time settings’ section click on the ‘Start/Restart’ sub-section and check that the ‘calculation restart’ option is off. It is possible to specify a checkpoint frequency by clicking on the ‘Advanced options’.

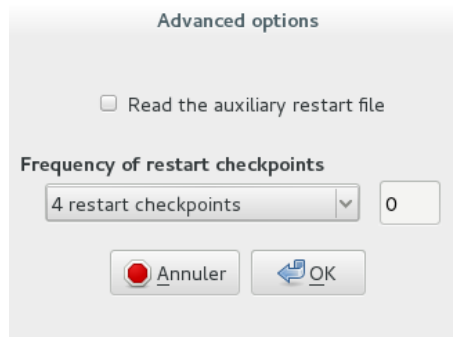

Figure III.20: Checkpoint frequency.

Note: The latest ‘4 restart checkpoints’ creates **restart** files. This could be useful in case of computing crash to restart the simulation from a restart file. ‘4 restart checkpoints’ means a restart file is written at 25%, 50%, 75% and 100% of the process. To run the simulation press the ‘Run or submit solver’



A new window will open allowing you to specify some calculation options (Figure V.2). Here, you can change the ‘Number of processes’ to those that you require for running the simulation.

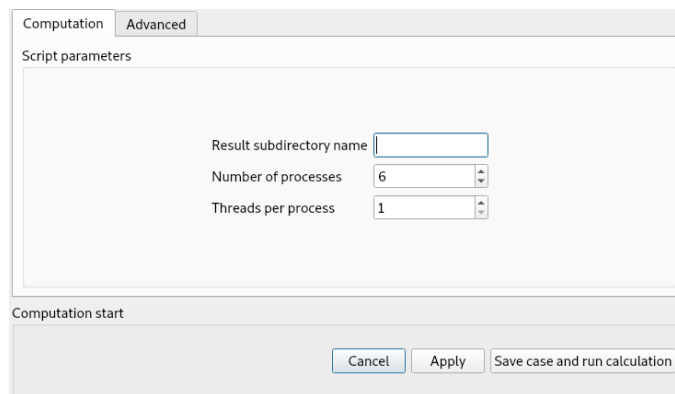

Figure III.21: Batch calculation settings.

After specifying ‘Number of processes’, press the ‘Save case and run calculation’ button to run the simulation.

The pop-up panel for the run opens, listing in real time the different stages of the calculation, from user-subroutines compilation to saving the results.

Wait for the calculation to complete and open the ‘listing’ file in your ‘Mixing_Tee/RANS/RESU/DateOfRunTimeOfRun/’ directory. Verify that the residuals listed under ‘drift’ in the ‘Information on Convergence’ table have dropped several orders of magnitude for all variables (pressure,

velocity, temperature), showing that the calculations have fully converged to a steady-state solution (Figure III.24).

```

** INFORMATION ON CONVERGENCE
-----
Variable      Rhs norm      N_iter  Norm. residual  Drift  Time residual
-----
c Velocity    0.14509E+01    9   0.25066E-01   0.37483E+04 0.43736E+04
c Velocity[X]                0.35930E+04
c Velocity[Y]                0.67624E+00
c Velocity[Z]                0.15465E+03
c Pressure    0.32229E+00    62   0.24892E+00   0.45663E+00 0.49344E+04
c k           0.87740E-01    7   0.16910E-03   0.77921E-05 0.35845E+03
c epsilon     0.72170E+00    10   0.54243E-02   0.14996E+00 0.37978E+04
c TempC      0.83217E+07    6   0.36687E-04   0.86195E+02 0.40928E+02
-----

```

Figure III.22: After 1 iteration.

```

** INFORMATION ON CONVERGENCE
-----
Variable      Rhs norm      N_iter  Norm. residual  Drift  Time residual
-----
c Velocity    0.89939E+01    3   0.66946E-02   0.68502E-03 0.75234E+00
c Velocity[X]                0.28004E-03
c Velocity[Y]                0.51540E-04
c Velocity[Z]                0.35344E-03
c Pressure    0.13382E-01    11   0.22771E-02   0.34282E-01 0.34328E+00
c k           0.12999E+00    4   0.25161E-04   0.10390E-07 0.20431E+00
c epsilon     0.98444E+00    3   0.63630E-04   0.10842E-05 0.25823E+00
c TempC      0.10193E+07    4   0.41188E-02   0.25600E+00 0.46342E+00
-----

```

Figure III.23: After 3000 iterations.

Figure III.24: Convergence history from 'listing' file.

You can now proceed with examining and post-processing the results by returning to the SALOME platform.

4 Results analysis

In this section, the results obtained from the steady-state simulation using k- ϵ LP turbulence model are compared to experimental data [4]. In the first instance, the y^+ is checked along the wall to ensure that y^+ is within the limits of the law of the wall model then a clip plane is used to cut the volume mesh along the main pipe in order to visualise the mixing between the hot and the cold fluid streams. Finally, the velocity and the normalised temperature are extracted along measurement lines after the T-Junction in order to compare predicted and experimental data.

4.1 Importing code_saturne Results into SALOME/ParaViS

Start a SALOME session in the usual manner and select 'ParaViS' from the drop-down module selector in the top menu bar. The name of the module will add itself to the 'Object Browser' list and the ParaView-specific panels and menus will be activated, including a new 'ParaView scene viewer' window.

Before loading the run data in ParaViS, follow the steps described in Tutorial 1 Part II [5], to modify the default colour schemes.

In the ‘Pipeline Browser’ panel on the left-hand side, right click and select ‘Open’ in the drop-down menu. Point to the ‘RESULTS_FLUID_DOMAIN.case’ file in the RESU directory for the run that has just finished:

`../Mixing_Tee/RANS/RESU/DateOfRunTimeOfRun/postprocessing/RESULTS_FLUID_DOMAIN.case`

Then, follow the steps described in Tutorial 3 Part I [9], to create the ‘CellDataPointData1’ object used for post-processing.

Point to the ‘RESULTS_BOUNDARY.case’ file in the RESU directory. Repeat the same operation to create the ‘CellDataPointData2’ object

4.2 Checking the y^+ at the boundaries

The listing file after 3000 iterations is showing a y^+ in a range between 22 and 176 as shown in Figure III.25.

```

** BOUNDARY CONDITIONS FOR SMOOTH WALLS
-----
                                         Minimum   Maximum
-----
Rel velocity at the wall uiptn :  0.13849E-01 0.11978E+01
Friction velocity          uet   :  0.14613E-02 0.10954E+00
Friction velocity          uk    :  0.19455E-01 0.74442E-01
Dimensionless distance     yplus :  0.22559E+02 0.17619E+03
Friction thermal sca.      tstar :  0.00000E+00 0.00000E+00
Rough dim-less th. sca.   tplus :  0.42264E+02 0.58702E+02
-----
Nb of reversal of the velocity at the wall :      0
Nb of faces within the viscous sub-layer   :      0
Total number of wall faces                  :    39572
-----

```

Figure III.25: Boundary information after 3000 iterations.

A visualization of ‘CellDataPointData2’ on Paravis enable to locate where the low y^+ are located as well as the high y^+ (Figure III.26).

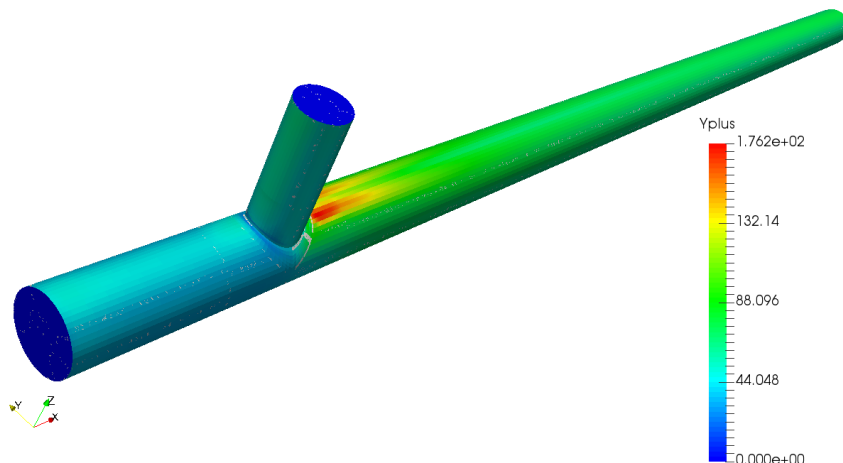

Figure III.26: Visualisation of the y^+ on ‘CellDataPointData2’.

4.3 Visualising data on a slice plane

In the 'Pipeline Browser' select the 'CellDataPointData1' object and click on **Filters** ⇒ **Common** ⇒ **Slice** in the top menu or click on the 'slice' icon. In the 'Object Inspector' ⇒ 'Properties' tab choose the 'Y Normal' direction and leave the default coordinate of the slice origin, then press 'Apply'. Click on the 'Display' tab of the 'Object Inspector' to choose the 'TempC' as 'Color by' as shown in Figure III.27. Then click on the 'Edit Color Map' button to pop-up the 'Color Scale Editor'. In this panel, click on 'Color Legend' to launch the 'Color legend' window and tick the 'Show Color Legend' box to add a colour legend to the scene.

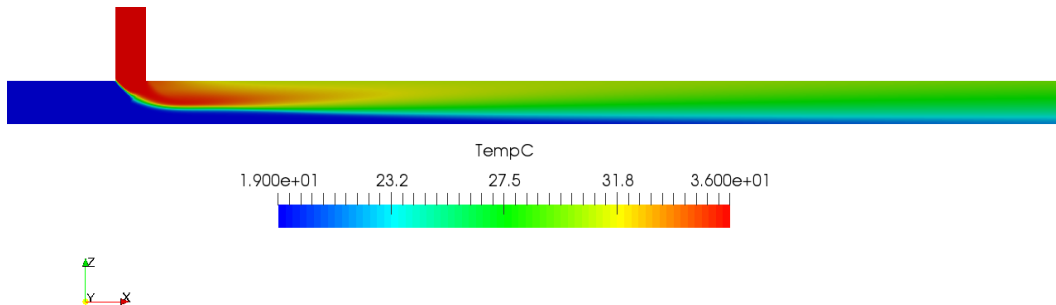

Figure III.27: Temperature field in the plane (xz).

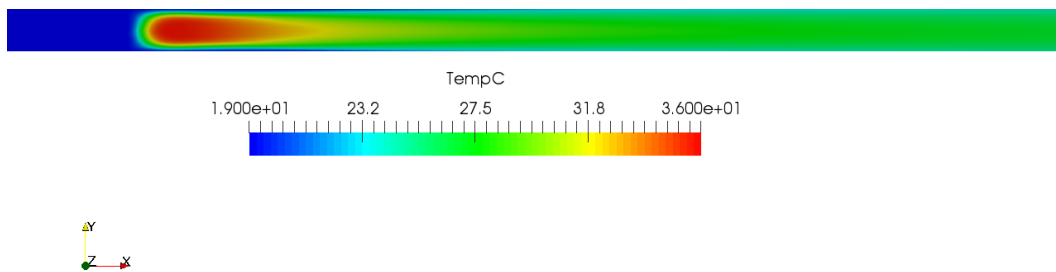

Figure III.28: Temperature field in the plane (xy).

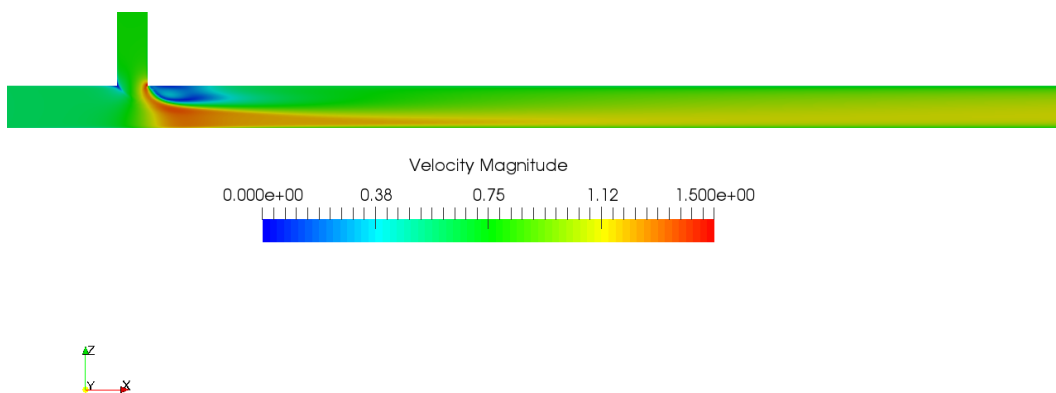

Figure III.29: Velocity magnitude field in the plane (xz).

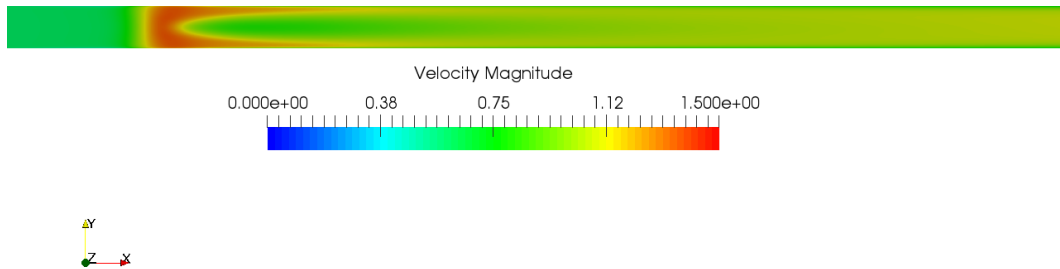

Figure III.30: Velocity magnitude field in the plane (xz).

4.4 Extracting line data

To prepare the extraction of the data, select the ‘CellDataPointData1’ object and click on **Filters** ⇒ **Common** ⇒ **Calculator**. Set the calculator with the “y” coordinates by clicking on “Scalars” and selecting “coordsY”, Figure III.31. For the post-processing of the vertical data, create a calculator for the “z” coordinates.

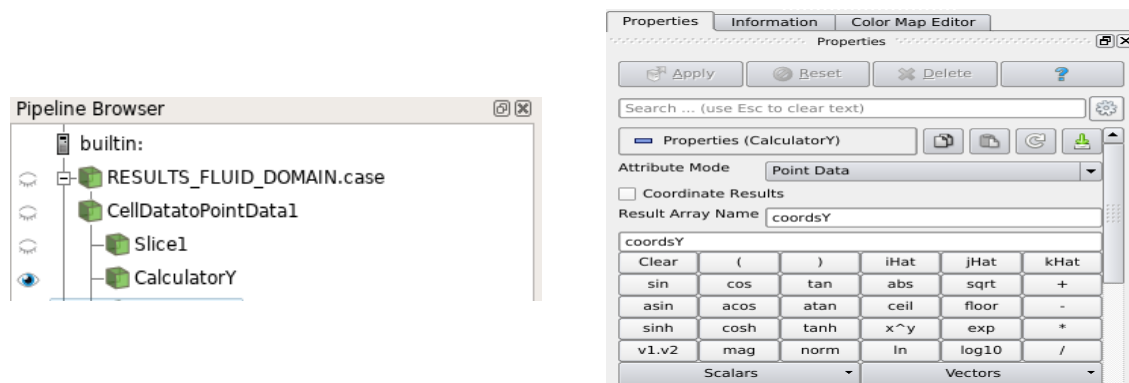

Figure III.31: Creating a calculator for y coordinates.

In order to plot the data along a line going through the computational domain, select the ‘Calculator’ object and click on **Filters** ⇒ **Data Analysis** ⇒ **Plot Over Line**. In the ‘Object Inspector’ ⇒ ‘Properties’ tab enter the coordinates of the two points which will define the line as shown in the Figure III.32. This line will go through the main pipe along the horizontal diameter at $x=0.224\text{m}$ after the Tee.

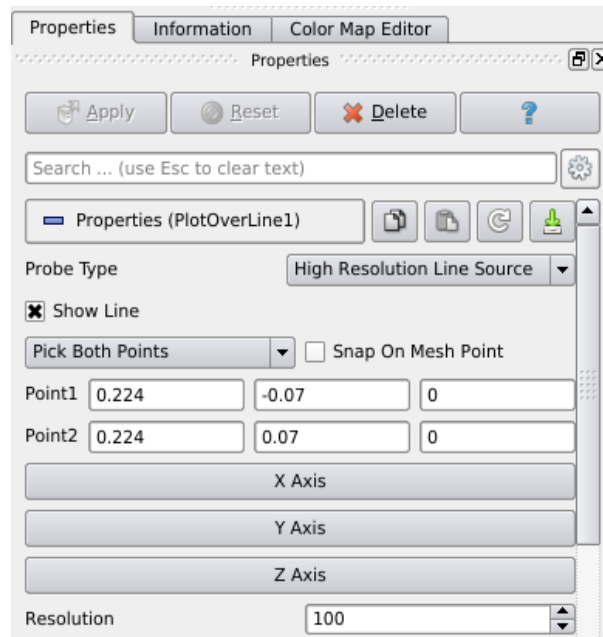

Figure III.32: Properties specification for the PlotOverLine.

After pressing 'Apply', you will see that the scene window which is named 'Layout #1' is cut into two parts. On the left is the 3D colour view and on the right is the 2D graph. In this tutorial we want to have one 'Layout' per graph so close the graph view by clicking on the cross button at the top right hand corner of the view. Next, click on the '+' icon just next to the 'Layout #1' tab to create the 'Layout #2', as shown in Figure III.33.

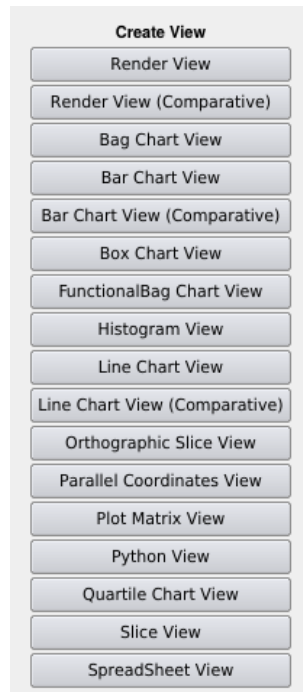

Figure III.33: ParaView 'Create View' menu.

Click on the 'Line Chart View' button in 'Layout #2' and click on the 'eye' icon at the left hand of

EDF R&D	code_saturne version 8.0 tutorial: Turbulence simulation in a mixing tee	code_saturne documentation Page 28/127
---------	---	--

the 'PlotOverLine1' in 'Pipeline Browser'. As a result, all data available in the computational domain are plotted in the 'Layout #2' panel. In order to plot only the x-component of the velocity, in the 'Display' tab of the 'Object Browser' select only the 'Velocity' variable in the 'Series Parameters' area and choose 'coordsY' which corresponds to the y-coordinate created by the calculator (Figure III.31).

In order to add the experimental data to the graph, file 'exp_u16Dh.csv', please follow the instructions of tutorial 1 Part II [5]. All the data necessary to create the different files containing the experimental data are listed in Appendix 1. By way of an example, take the data of the Table VII.2. Follow the instructions in Tutorial 1 Part II [5], in order to create the *.csv files. When the 'exp_u16Dh.csv' is in the 'Pipeline Browser', repeat the procedure as for the 'PlotOverLine1' (close the default view after pressing 'Apply', select the 'Layout #2', click on the 'eye' icon of the 'exp_u16Dh.csv' object and choose the correct data to plot).

Chapter IV

Part 3 - Comparison of Predicted and Experimental Data

1 Comparison of the axial velocity with the experimental data.

You can find in Figure IV.1a to Figure IV.2d the computational results compared to the experimental for the axial velocity along vertical and horizontal lines.

1.1 Comparison along horizontal lines.

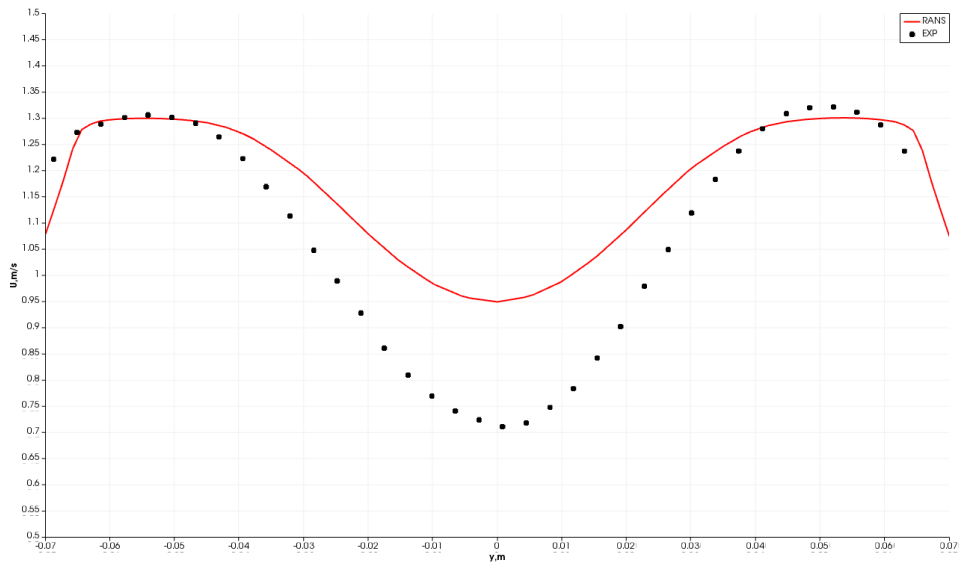

(a) at $x=1.6D$

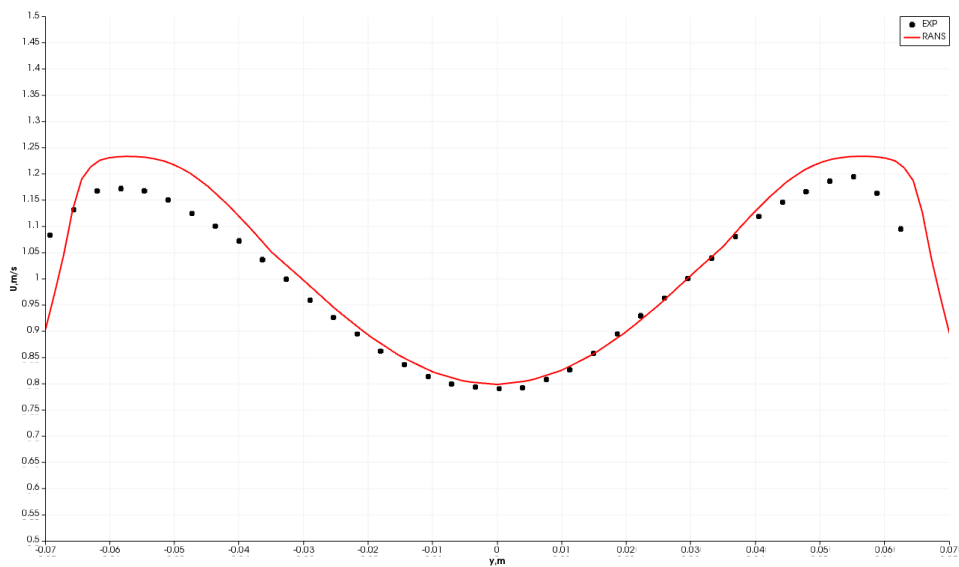

(b) at $x=2.6D$

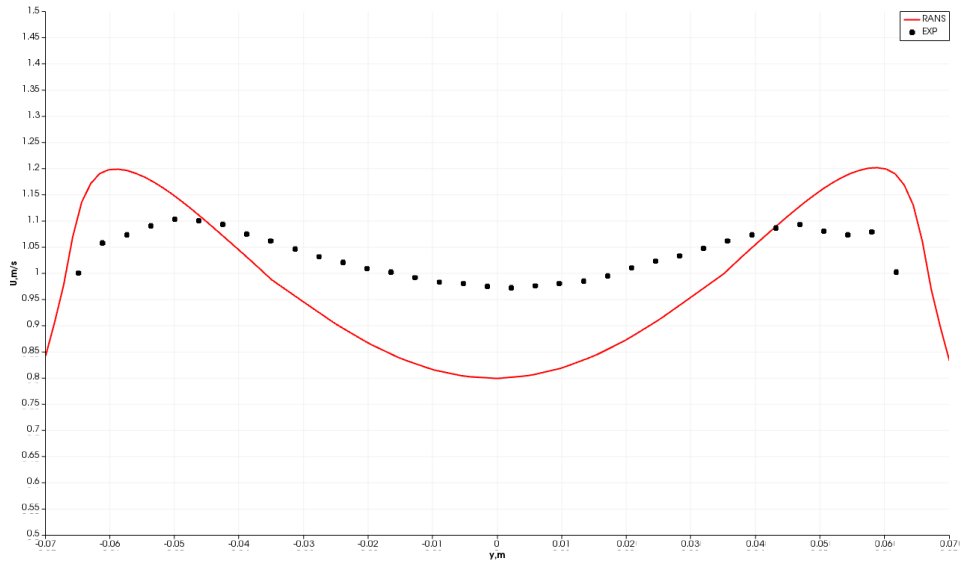
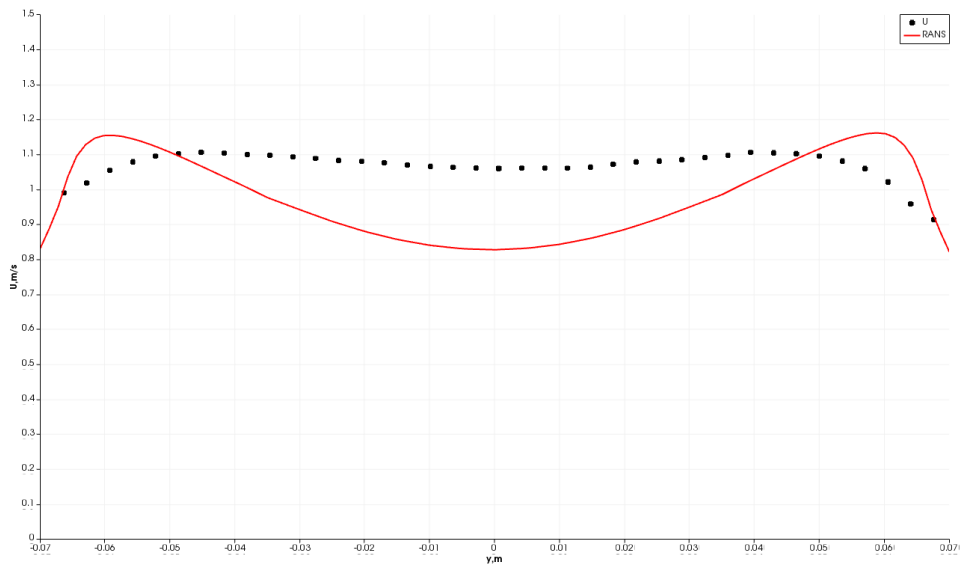
(c) at $x=3.6D$ (d) at $x=4.6D$ Figure IV.1: x-component of the velocity for the RANS simulation along horizontal lines at $x = 1.6D$, $2.6D$, $3.6D$ and $4.6D$.

1.2 Comparison along vertical lines

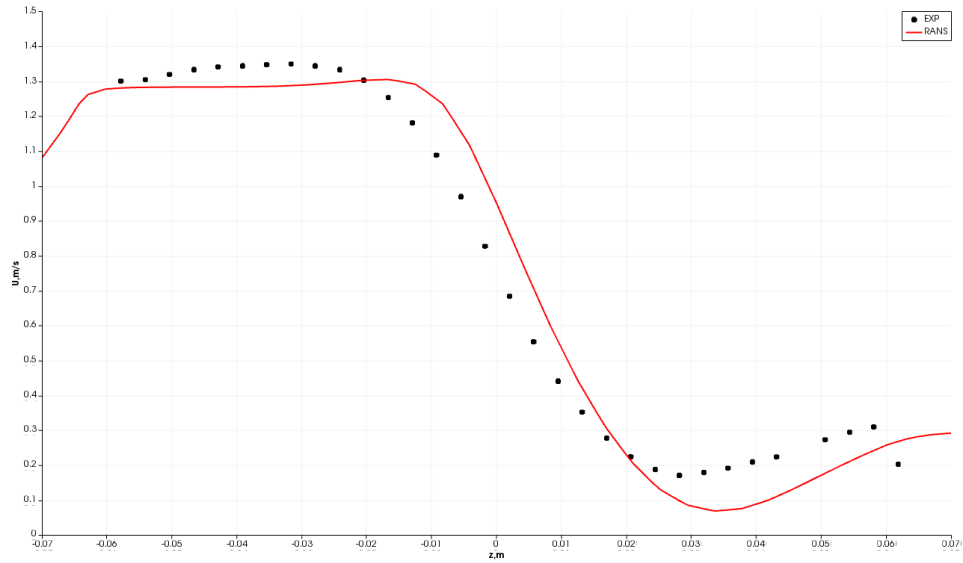
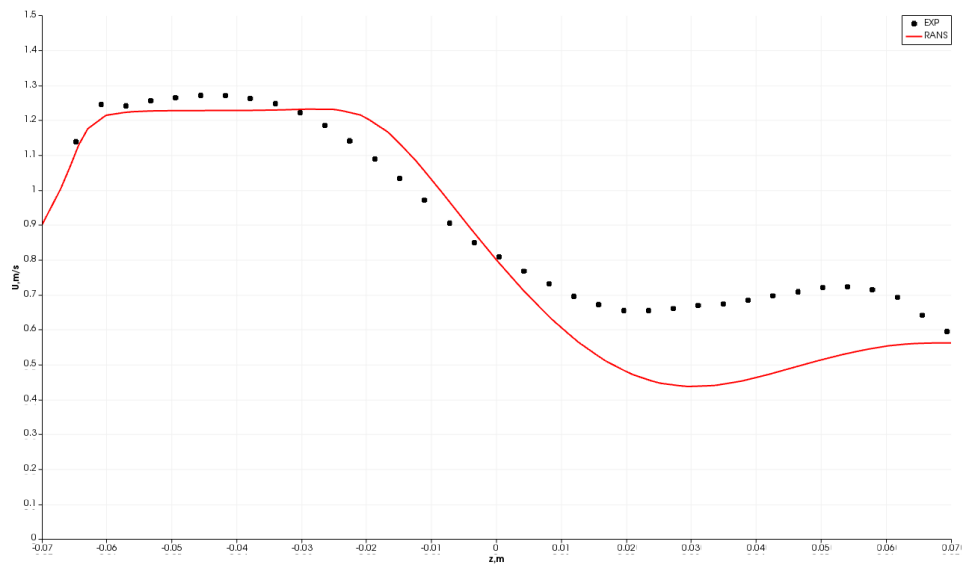
(a) at $x=1.6D$ (b) at $x=2.6D$

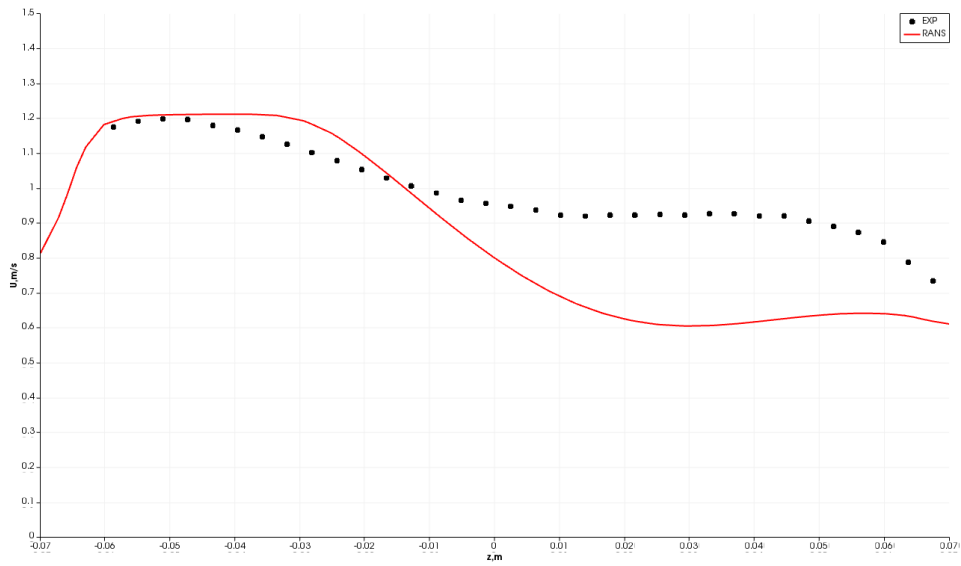
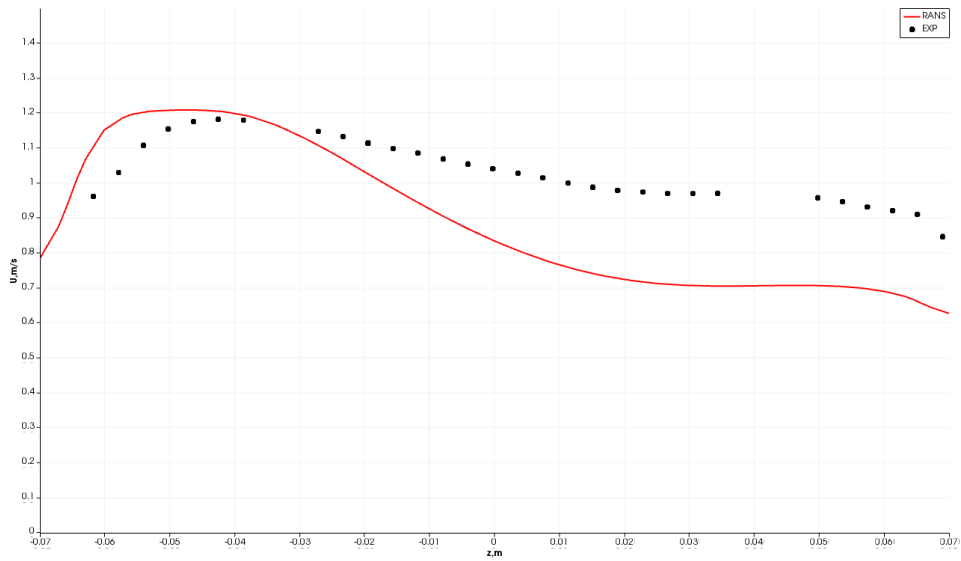
(c) at $x=3.6D$ (d) at $x=4.6D$ Figure IV.2: x-component of the velocity for the RANS simulation along vertical lines at $x = 1.6D$, $2.6D$, $3.6D$ and $4.6D$.

2 Comparison the dimensionless temperature with the experimental data

To plot the dimensionless temperature create the variable " $\langle T \rangle^*$ " in a calculator. This temperature is given by :

$$\langle T \rangle^* = \frac{\langle T \rangle - T_{cold}}{T_{hot} - T_{cold}} \quad (\text{IV.1})$$

The dimensionless temperature in Figure IV.3 is plotted along the domain at $y=0$ and $z=0.07$. Figure IV.4 is plotted along the domain at $y=-0.07$ and $z=0$.

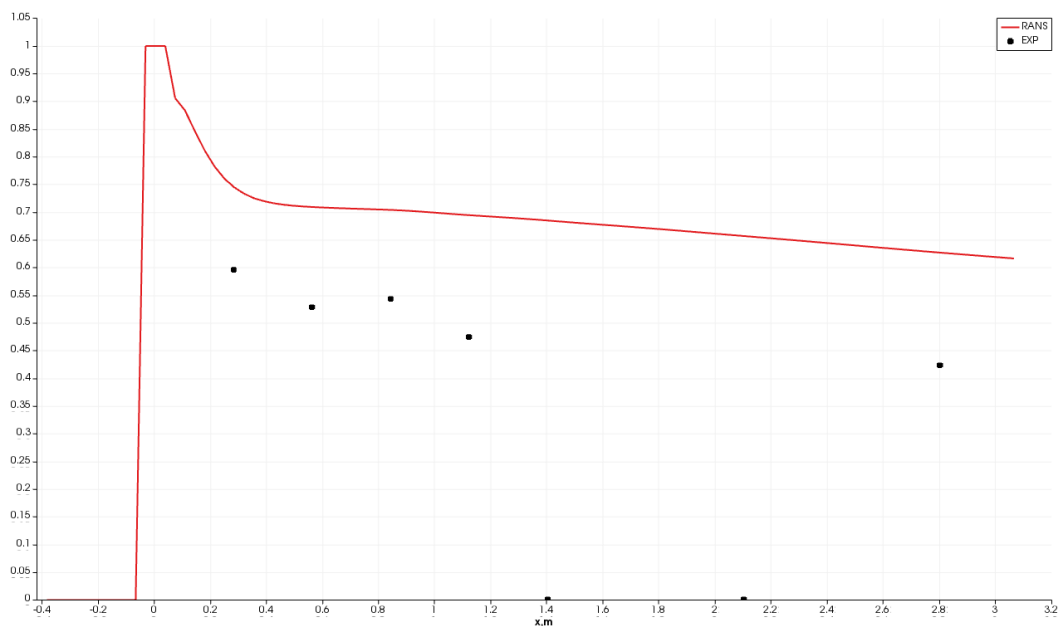

Figure IV.3: Dimensionless temperature along the lines defined in the main pipe at $y=0$ and $z=0.07$.

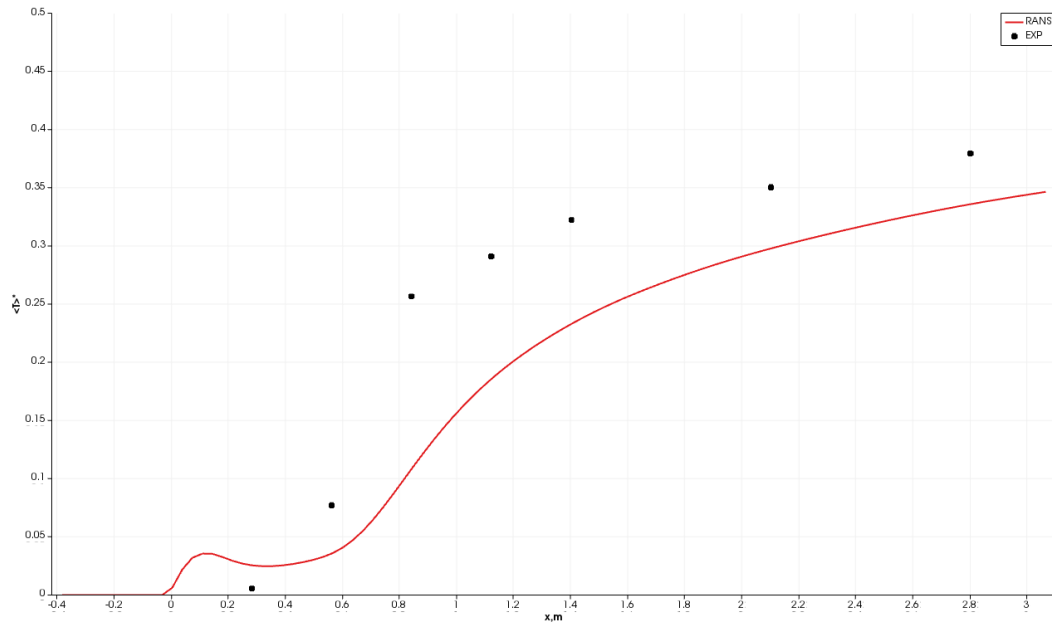

Figure IV.4: Dimensionless temperature along the lines defined in the main pipe at $y=-0.07$ and $z=0$.

Chapter V

Part 4 - LES Computation

1 What you will learn

In this fourth part of this tutorial, you will learn how to set-up an LES simulation of the flow in the T-Junction. The set-up procedure involves user coding for the Synthetic Eddy Method for estimating the turbulent profiles at the hot and cold flow inlets to the computational domain.

1.1 Create a case with “copy-from” feature

In order to **avoid setting again** the RANS case as described in the previous section, the second case will be created using the “copy-from” feature. In SALOME object browser, right click on the study name *Mixing-Tee* and select “Add case”. Then in the pop-up window, enter the name *LES* for example, toggle the option “copy from existing case” and choose the first case directory *RANS*. Finally click on “OK”.

1.2 Setting up the CFD simulation

In this section, only the modifications required in order to set-up the LES calculation are presented here.

The code_saturne case is set-up and run from the CFDStudy module. Move to the ‘LES’ case directory and, selecting the setup.xml file, open the GUI. Verify that the GUI has correctly recognised the case directory structure.

You can now proceed with setting up the case, in the top down order of the sections in the left-hand column of the GUI.

1.3 Mesh Tab

In the ‘Mesh’ section add the volume mesh ‘Mesh_LES.med’

1.4 Calculation features

Turbulence models Change ‘Turbulence models’ to ‘(LES Smagorinsky)’ under the ‘Calculation features’ section

1.5 Time settings

Choose the ‘constant’ option for the ‘Time step option’ and specify a ‘Reference time step’ of 0.00015s as shown in the Figure V.1. This time step is adapted to have a CFL inferior to 1 for the mesh ‘Mesh_LES.med’

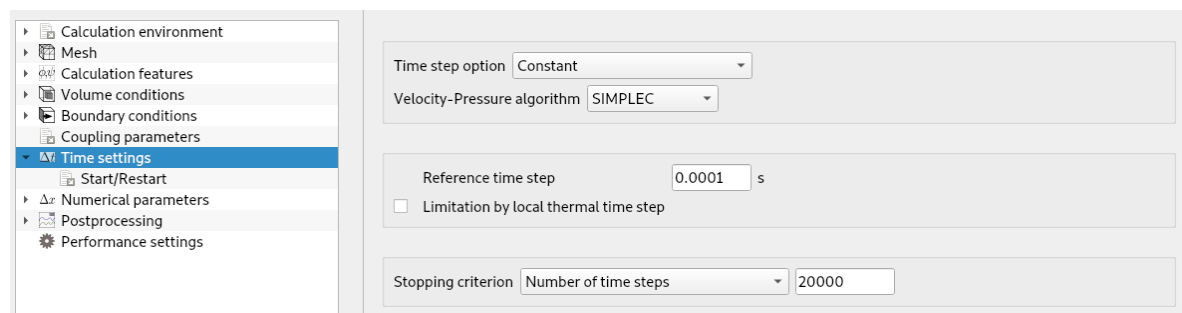

Figure V.1: Time step menu.

The setting up of the LES simulation using the GUI has now finished and the 'setup.xml' file should be saved at this point. However, before you can run the simulation, user coding for the subroutine 'cs_user_les_inflow.f90' must be done.

2 Programming LES inflow boundary conditions with user coding

The specification of the LES inflow boundary conditions is done in the 'cs_user_les_inflow-base.f90' subroutine. Copy the sample subroutine 'cs_user_les_inflow-base.f90' from the tutorial's `../MixingTee/LES/SRC/EXAMPLES` directory to your SRC directory in order to create a local copy named 'cs_user_les_inflow.f90'. As before, you will be able to customise this subroutine which will be automatically compiled and linked to the 'cs_solver' executable at run time. Then, open your local version of this file using the text editor of your choice.

This file contains three subroutines 'cs_user_les_inflow_init', 'cs_user_les_inflow_define' and 'cs_user_les_inflow_advanced'. The first routine is for specifying the global characteristics of synthetic turbulence at the domain inlets. The second routine is for specifying the characteristics of specific inlets. The last routine is to specify the accurate specification of target statistics at all inlets.

Here we describe the main parts and the logic behind them.

1. In the subroutine 'cs_user_les_inflow_init', specify the number of synthetic turbulent inlets, here 2 inlets are used.
2. In the subroutine 'cs_user_les_inflow_define':
 - (a) Initialise the velocity, the turbulent kinetic energy and the dissipation scales to zero (these values will be specified in the subroutine 'cs_user_les_inflow_advanced')
 - (b) For the cold inlet specify that:
 - i. The Synthetic Eddy Method is used
 - ii. 300 synthetic eddies contribute to the turbulent fluctuations
 - iii. This inlet is applied to the boundary condition 'inlet_1' through the 'getfbr' subroutine
 - (c) For the hot inlet specify that:
 - i. The Synthetic Eddy Method is used
 - ii. 300 synthetic eddies contribute to the turbulent fluctuations
 - iii. This inlet is applied to the boundary condition 'inlet_2' through the 'getfbr' subroutine
3. In the subroutine 'cs_user_les_inflow_advanced':
 - (a) Initialise the variables concerning the inlet velocities, hydraulic diameters and other variables
 - (b) Compute the mean velocity vector, Reynolds stresses and the dissipation rate. For that you can use Exemple 2.

3 Running and analysing the simulation for 3s of physical time

To run the simulation press the 'Run or submit solver' button .

A new window will open allowing you to specify some calculation options (Figure V.2). Here, you can change the 'Number of processes' to those that you require for running the simulation.

Computation **Advanced**

Script parameters

Result subdirectory name

Number of processes

Threads per process

Computation start

Figure V.2: Batch calculation settings.

After specifying ‘Number of processes’, press the ‘Save case and run calculation’ button to run the simulation.

The pop-up panel for the run opens, listing in real time the different stages of the calculation, from user-subroutines compilation to saving the results.

The calculation is initially run for 3s of real time in order to remove the initial field from the averaging that will follow after 3s. When the 3s of physical time is reached, you can proceed with time-averaging process.

4 Setting the simulation for 8s of physical time

4.1 Time settings

To complete this computation by reaching 8s of physical time simulation you must follow the next steps:

Return to the ‘Time settings’ section. Keep the time step constant at 0.00015s and choose 53334 iterations in order to simulate 8s of physical time as shown in Figure [V.3](#).

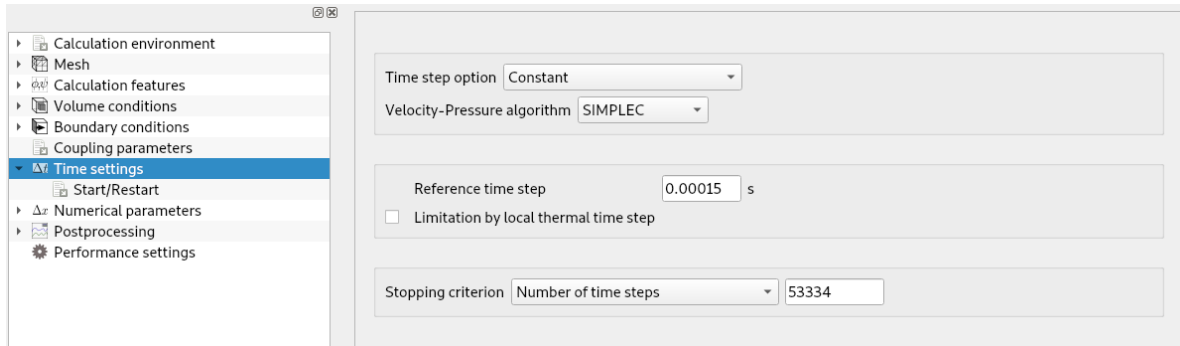

Figure V.3: Time step menu.

Go to the ‘Start/Restart’ sub-section under the ‘Time settings’ section then enable the ‘Restart from checkpoint’ option in order to select the checkpoint folder of the previous calculation. The directory structure of the ‘checkpoint’ section should be `MixingTee/LES/RESU/DateOfRunTimeOfLastRun/checkpoint`.

4.2 Postprocessing Tab - Time averages

In this tutorial, you will want to compute the average of the temperature, the velocity components and the Reynolds stresses components. In the section ‘Postprocessing’, click on the ‘Time averages’ sub-section. For the temperature time average, enter ‘the label of time average’ ‘average.T’ in the panel, leave the other parameters at their default values and select the variable ‘TempC’ from the drop-down menu. Then, click on the icon in order to obtain the final set-up shown in Figure V.4 and click on ‘Add’.

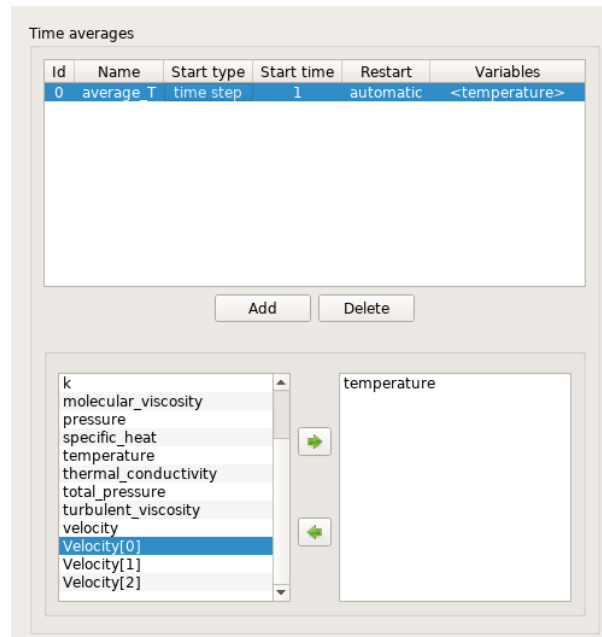

Figure V.4: Temperature time average.

Repeat the process for the velocity components, as shown in the Figure V.5.

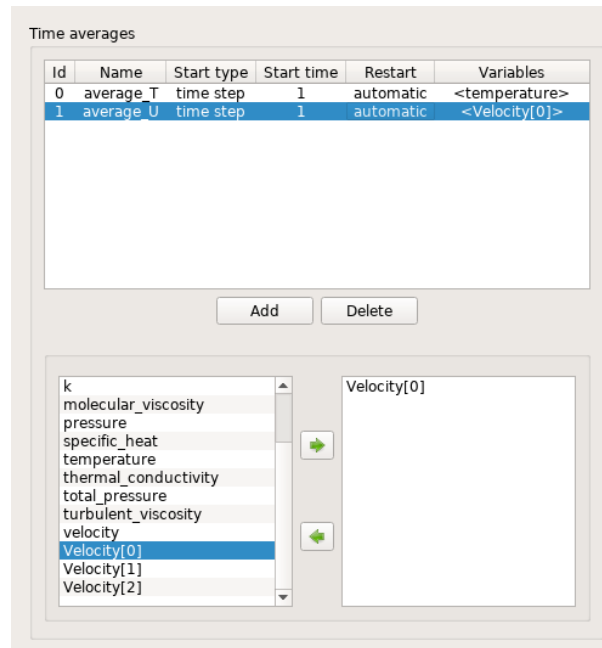
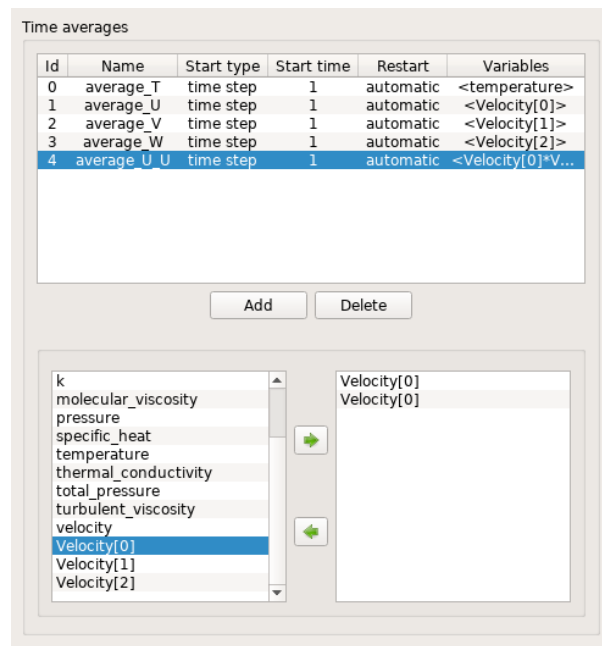
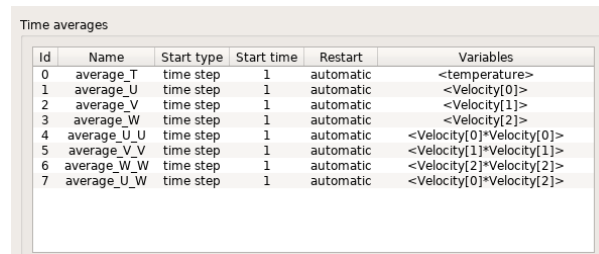

Figure V.5: Velocity time average.

This functionality allows the calculation of time averages of the type $\langle f_1 * f_2 \dots * f_n \rangle$. For the component $u'u'$ of the Reynolds stress, specify a 'label of time average' 'average_U_U' and insert twice the 'VelocityX' from the drop-down menu (Figure V.6).

Figure V.6: $u'u'$ time average.

It is possible to modify a time average of a variable. First, you select the average to be modified by clicking on it. Then, you can change that which is necessary and confirm the change by clicking on 'Modify'. The list of the time averages of variables necessary for the comparison with experimental data is listed in the Figure V.7.



id	Name	Start type	Start time	Restart	Variables
0	average_T	time step	1	automatic	<temperature>
1	average_U	time step	1	automatic	<Velocity[0]>
2	average_V	time step	1	automatic	<Velocity[1]>
3	average_W	time step	1	automatic	<Velocity[2]>
4	average_U_U	time step	1	automatic	<Velocity[0]*Velocity[0]>
5	average_V_V	time step	1	automatic	<Velocity[1]*Velocity[1]>
6	average_W_W	time step	1	automatic	<Velocity[2]*Velocity[2]>
7	average_U_W	time step	1	automatic	<Velocity[0]*Velocity[2]>

Figure V.7: List of all time averages.

5 Running and analysing the simulation for 8s of physical time

Now launch the calculation as explained earlier by pressing the 'Run or submit solver' button .

6 Results Analysis

For the post-processing of the results, follow the instructions given in [4.4](#).

Chapter VI

References

1 References

- [1] www.salome-platform.org
- [2] F. ARCHAMBEAU, N. MÉCHITOUA, M. SAKIZ,
code_saturne: a Finite Volume Code for the Computation of Turbulent Incompressible Flows - Industrial Applications,
International Journal on Finite Volumes, Vol. 1, 2004.
- [3] www.code-saturne.org
- [4] -
Experimental data of T-Junction benchmark,
VATTENFALL R&D, 2009.
- [5] EDF,
Tutorial 1: Shear Driven Cavity Flow,
code_saturne Tutorial Series
- [6] http://docs.salome-platform.org/salome_6_6_0/gui/HEXABLOCK/index.html
- [7] INCROPERA AND DEWITT,
Heat and Mass transfer,
Fourth edition, 2000.
- [8] N. JARRIN, S. BENHAMADOUCHE, D. LAURENCE, R. PROSSER,
A synthetic-eddy-method for generating inflow conditions for large-eddy simulations,
International Journal of Heat and Fluid Flow, Volume 27, Issue 4, August 2006, Pages 585-593
- [9] EDF,
Tutorial 3: Heated Square Cavity Flow,
code_saturne Tutorial Series

Chapter VII

Appendix

1 Appendix A – Experimental Data from [4]

Experimental data from [4] are listed in the Table VII.1 to Table VII.9. The Table VII.1 presents the dimensionless temperature along the top of the main pipe at 0deg and along the bottom of the main pipe at 180deg. The Table VII.2 to Table VII.5 are the U and V components of the velocity and the Reynolds stresses on horizontal lines at $x=1.6D$, $2.6D$, $3.6D$ and $4.6D$ respectively. The Table VII.6 to Table VII.9 are the U and V components of the velocity and the Reynolds stresses on vertical lines at $x=1.6D$, $2.6D$, $3.6D$ and $4.6D$ respectively.

x	0deg (y=0.07)	180deg (y=-0.07)
0.28	0.5950	0.0051
0.56	0.5274	0.0769
0.84	0.5423	0.2561
1.12	0.4737	0.2906
1.4	NaN?	0.3219
2.1	NaN?	0.3502
2.8	0.4224	0.3791

Table VII.1: Experimental dimensionless temperature along the lines defined in the main pipe at ($y=0.07$; $z=0$) and ($y=-0.07$; $z=0$) [4] [4].

y	U	V	uu	vv	uv
-0.068803501	1.220961266	0.0080508	0.016806403	0.003684748	-0.000320576
-0.065143373	1.272156037	0.036178944	0.013349062	0.005739933	0.000132636
-0.061483245	1.287670348	0.007311955	0.014539606	0.007853589	0.000463675
-0.057823117	1.300325409	-0.002032071	0.017086371	0.010877009	0.000619996
-0.054162989	1.305862451	-0.009434521	0.02108371	0.016523966	0.001532841
-0.050502861	1.30103421	-0.012886409	0.028432521	0.02160839	0.00509258
-0.046842733	1.290144564	-0.006630974	0.037175548	0.026161018	0.007402013
-0.043182604	1.263691319	-0.002114936	0.048615376	0.032273092	0.009368141
-0.039522476	1.22199861	0.003949942	0.064236241	0.041531123	0.011279648
-0.035862348	1.168973395	0.005407237	0.082154374	0.049030202	0.013744189
-0.03220222	1.112672368	0.004366237	0.102669408	0.056323366	0.017127909
-0.028542092	1.047415842	0.006996903	0.122138707	0.064871654	0.01660063
-0.024881964	0.988924841	0.012906095	0.129131566	0.074142514	0.013766377
-0.021221836	0.927699906	0.01423193	0.142070022	0.081606706	0.014728216
-0.017561708	0.860383309	0.016585659	0.154439636	0.086292057	0.014205319
-0.01390158	0.808679486	0.022463178	0.159971359	0.08678276	0.012338107
-0.010241451	0.769015946	0.01556741	0.158728468	0.091342135	0.011248339
-0.006581323	0.740261152	0.010405492	0.158311994	0.091807149	0.010732402
-0.002921195	0.723447658	0.010103166	0.15879933	0.094939579	0.008482735
0.000738933	0.710321741	0.014230932	0.159189175	0.095000866	0.006181472
0.004399061	0.717625555	0.014685395	0.157553876	0.093895669	0.003943113
0.008059189	0.746772417	0.010404808	0.15904384	0.09196193	0.003450575
0.011719317	0.782873507	-0.003508939	0.162104348	0.088615309	0.002228167
0.015379445	0.841142639	-0.003193653	0.162902251	0.086685592	-0.004351654
0.019039574	0.901711036	-0.002126663	0.163693601	0.083417332	-0.005159765
0.022699702	0.978435006	-0.007529482	0.14988788	0.077438934	-0.010079361
0.02635983	1.048777782	-0.005956403	0.130931978	0.068254219	-0.014573342
0.030019958	1.118789385	-0.006130006	0.104269032	0.060250078	-0.013488905
0.033680086	1.182609871	-0.01020512	0.082532171	0.047382859	-0.008778693
0.037340214	1.236606974	-0.001066346	0.057044378	0.03904077	-0.009019601
0.041000342	1.279031712	0.006137361	0.041672372	0.033292919	-0.008095095
0.04466047	1.308363214	-0.003099608	0.028704703	0.024498138	-0.00419303
0.048320598	1.319369484	-0.001702236	0.022576626	0.018235141	-0.00356895
0.051980727	1.321133913	-0.000665381	0.016679991	0.012408706	-0.001077844
0.055640855	1.31053268	-0.007085745	0.01391511	0.008643992	-0.000300852
0.059300983	1.286586848	-0.016616003	0.012555618	0.005567511	-9.98E-05
0.062961111	1.236213676	-0.025118743	0.017471484	0.002323452	0.000660312

Table VII.2: Experimental data along a horizontal line defined at $x = 1.6D$ and $z=0$ [4].

y	U	V	uu	vv	uv
-0.069368535	1.082202739	0.026302991	0.038695911	0.007840121	0.002295221
-0.065708407	1.131046578	0.035433371	0.028031243	0.009267074	0.003859765
-0.062048279	1.166985976	0.037071193	0.025640287	0.013675077	0.00540781
-0.058388151	1.171782666	0.038566529	0.031786283	0.016835954	0.006296806
-0.054728023	1.167348604	0.036674632	0.032538149	0.020614559	0.00786736
-0.051067895	1.149949236	0.033123758	0.037408521	0.026404955	0.009072984
-0.047407766	1.123811353	0.031810201	0.045428415	0.033126556	0.011185124
-0.043747638	1.099509644	0.028389849	0.05226019	0.037951129	0.014134049
-0.04008751	1.071998363	0.029369624	0.060218483	0.042570819	0.016360686
-0.036427382	1.036329117	0.032669894	0.065899146	0.048751158	0.015959809
-0.032767254	0.998930657	0.034466616	0.073064337	0.052231505	0.016730107
-0.029107126	0.95867343	0.027886514	0.079520063	0.055805322	0.016930019
-0.025446998	0.925338541	0.029814858	0.080342487	0.057292124	0.013045066
-0.02178687	0.893781719	0.030764208	0.083688938	0.058288418	0.011910962
-0.018126741	0.861278943	0.032316221	0.083220585	0.059901962	0.013117824
-0.014466613	0.835528676	0.033209271	0.082663928	0.060811253	0.010500281
-0.010806485	0.813123652	0.034404578	0.080569423	0.061493656	0.008102665
-0.007146357	0.798648807	0.031215134	0.078576249	0.063455177	0.007179793
-0.003486229	0.793086657	0.028231063	0.07558212	0.063773323	0.004646465
0.000173899	0.789686558	0.028559546	0.073580275	0.063062361	0.001877638
0.003834027	0.791760175	0.025706662	0.076202974	0.064225946	-6.80E-05
0.007494155	0.807564044	0.024254404	0.080692485	0.063358101	-0.002722524
0.011154283	0.826577421	0.027537324	0.083442747	0.062115561	-0.003618879
0.014814412	0.857432698	0.030286232	0.082439545	0.065210008	-0.006605145
0.01847454	0.893976145	0.026540454	0.079182009	0.064305459	-0.009463321
0.022134668	0.929206961	0.023501275	0.077320256	0.060805833	-0.012073691
0.025794796	0.962237057	0.013935585	0.077674665	0.056827215	-0.012094994
0.029454924	1.000052663	0.003634836	0.076472514	0.051245221	-0.010797203
0.033115052	1.039073637	-0.003050727	0.071488631	0.046273464	-0.011956342
0.03677518	1.079924784	-0.00253535	0.065033301	0.041336503	-0.013450124
0.040435308	1.118071692	-0.004411852	0.055176102	0.036497281	-0.012149277
0.044095437	1.145131275	-0.004150723	0.045473452	0.03269635	-0.01196506
0.047755565	1.165485328	-0.004920335	0.036857727	0.028393736	-0.010486433
0.051415693	1.185875494	-0.008496849	0.027216309	0.022528539	-0.008366044
0.055075821	1.194083949	-0.013409531	0.025368073	0.016344231	-0.006755233
0.058735949	1.162226174	0.001728245	0.029157959	0.01099537	-0.004571036
0.062396077	1.094684941	0.006786894	0.038650217	0.010413713	-0.00192275

Table VII.3: Experimental data along a horizontal line defined at $x = 2.6D$ and $z=0$ [4].

y	U	V	uu	vv	uv
-0.064942165	0.999567818	0.009954602	0.029016388	0.008540657	9.47E-05
-0.061218133	1.057757626	0.004135579	0.028858794	0.0103888	0.000910212
-0.057494101	1.072924419	0.008392337	0.030050541	0.013413533	0.00196188
-0.053770069	1.090139419	0.006314843	0.031057516	0.016118005	0.003488428
-0.050046037	1.102540116	0.005657113	0.031159201	0.018934966	0.004500034
-0.046322005	1.099709414	0.0040022	0.031816112	0.021012532	0.00586983
-0.042597973	1.093006917	0.008850913	0.030656428	0.018450632	0.005894702
-0.038873941	1.074345773	0.01021927	0.029318075	0.020392342	0.005700237
-0.035149909	1.060961484	0.005879035	0.030851	0.027083946	0.006987888
-0.031425877	1.045948346	0.003944355	0.031528389	0.02896152	0.007662895
-0.027701845	1.030735964	0.00285597	0.032496777	0.030275366	0.008154697
-0.023977813	1.020657541	0.003178069	0.034416098	0.03226989	0.005764448
-0.020253782	1.008273501	0.000930945	0.035054195	0.030847171	0.005836718
-0.01652975	1.002084348	0.00083683	0.034728355	0.031412221	0.005682902
-0.012805718	0.990839278	0.004780686	0.034036449	0.032887815	0.004158329
-0.009081686	0.982275657	0.007802901	0.033325668	0.034269964	0.002942319
-0.005357654	0.979729863	0.008560281	0.032865986	0.035012801	0.001258851
-0.001633622	0.974561526	0.005312477	0.033022983	0.034468453	0.000776853
0.00209041	0.97212795	0.00338701	0.034373612	0.034706914	0.00010455
0.005814442	0.975179785	0.002752661	0.034370339	0.03470714	-0.002198185
0.009538474	0.979582738	-0.001098453	0.034075185	0.033589896	-0.002365536
0.013262506	0.984652046	0.000404763	0.03476567	0.033805428	-0.003794216
0.016986538	0.994663571	0.000487668	0.036310626	0.033211698	-0.005896862
0.02071057	1.009783672	-0.004768269	0.037126843	0.031658488	-0.005443132
0.024434602	1.02254729	-0.006339431	0.03466642	0.031340528	-0.006791351
0.028158633	1.032503474	-0.009624849	0.034369533	0.0288003	-0.007398747
0.031882665	1.046962452	-0.023746891	0.033970426	0.020544993	-0.006235022
0.035606697	1.061100946	-0.029393032	0.033802898	0.015907466	-0.00537082
0.039330729	1.073241912	-0.013872118	0.033774269	0.018664718	-0.00645483
0.043054761	1.08612208	-0.038007553	0.034490763	0.012213388	-0.004446262
0.046778793	1.092421819	-0.062375854	0.035369231	0.007174623	-0.002727415
0.050502825	1.079983638	-0.041756481	0.032887519	0.009172826	-0.003020898
0.054226857	1.072927223	-0.010031112	0.03253559	0.012690408	-0.001670477
0.057950889	1.078399857	-0.006157044	0.036098903	0.012445449	-0.000642243
0.061674921	1.001946727	-0.012585638	0.036291396	0.008511331	0.000312972

Table VII.4: Experimental data along a horizontal line defined at $x = 3.6D$ and $z=0$ [4].

y	U	V	uu	vv	uv
-0.066407476	0.988708927	-0.015767472	0.027101743	0.00907339	-0.000416653
-0.062882707	1.017737232	-0.011512028	0.024849209	0.009340111	-8.32E-05
-0.059357939	1.05340401	-0.008319259	0.027504711	0.011023551	0.000955366
-0.055833171	1.078246118	-0.006477538	0.029499445	0.012934425	0.001404052
-0.052308403	1.093848403	-0.005790252	0.031196558	0.014276329	0.001699225
-0.048783635	1.100732808	-0.005465027	0.032311178	0.016288499	0.002408012
-0.045258867	1.105119368	-0.003335601	0.03087782	0.01786313	0.004085187
-0.041734099	1.102725302	-0.003186139	0.03085378	0.019670465	0.004391908
-0.038209331	1.098852833	-0.001409321	0.030553301	0.021950381	0.004748426
-0.034684563	1.096729814	-0.002413396	0.029890226	0.022742538	0.004907242
-0.031159794	1.091875875	-0.00573699	0.028576069	0.023714839	0.004788496
-0.027635026	1.087205502	-0.006791523	0.029298409	0.024855936	0.00448303
-0.024110258	1.082276254	-0.006576663	0.028929775	0.026695223	0.003880063
-0.02058549	1.079079469	-0.010419375	0.027801067	0.027087746	0.00375633
-0.017060722	1.075195002	-0.008924121	0.027596131	0.027613351	0.003183658
-0.013535954	1.06859212	-0.00753008	0.028256989	0.027858687	0.002847416
-0.010011186	1.065172938	-0.007426849	0.029327659	0.028392772	0.00294188
-0.006486418	1.061969967	-0.006351563	0.028493244	0.02795662	0.001799254
-0.00296165	1.060396701	-0.002560392	0.027950139	0.027596715	0.000867593
0.000563119	1.059204217	0.000471791	0.02820745	0.026398808	-0.000173785
0.004087887	1.05965793	-0.002139525	0.028077979	0.025757034	-0.000887411
0.007612655	1.059894843	-0.004035707	0.027265874	0.024594476	-0.00210305
0.011137423	1.059361401	-0.002693754	0.027511492	0.024751051	-0.00290675
0.014662191	1.062996836	-0.002728297	0.027582325	0.02491474	-0.003878176
0.018186959	1.071019346	-0.004423416	0.027974569	0.025718191	-0.004579473
0.021711727	1.077721766	-0.00673771	0.029100437	0.024998186	-0.00429708
0.025236495	1.080524357	-0.008494971	0.030396043	0.023228166	-0.00440375
0.028761263	1.08413835	-0.008220301	0.030732884	0.022283598	-0.00409482
0.032286032	1.090107392	-0.007397497	0.031180065	0.022010863	-0.004104643
0.0358108	1.096126295	-0.007186596	0.029732098	0.020785226	-0.004306261
0.039335568	1.104678601	-0.008159286	0.029849885	0.018718804	-0.004006554
0.042860336	1.103894488	-0.009366057	0.029981621	0.016448562	-0.003226551
0.046385104	1.101549312	-0.01124995	0.029582293	0.015731062	-0.002816598
0.049909872	1.093950886	-0.012199547	0.028284045	0.014719867	-0.002630838
0.05343464	1.080434602	-0.010639156	0.027282761	0.013268299	-0.00234641
0.056959408	1.058969242	-0.009022812	0.025724699	0.011044458	-0.002042546
0.060484177	1.02069144	-0.005366073	0.022281618	0.008210158	-0.000836225
0.064008945	0.957525994	0.00211208	0.019278774	0.005120943	2.72E-05
0.067533713	0.912716686	0.005829673	0.021250605	0.004642221	0.000363108

Table VII.5: Experimental data along a horizontal line defined at $x = 4.6D$ and $z=0$ [4].

z	U	W	uu	ww	uw
-0.057941698	1.299230276	0.005484151	0.007248031	0.000738478	-0.000484864
-0.054202146	1.303399456	0.006565643	0.005160965	0.001167607	-0.000466642
-0.050462594	1.31825248	0.001318495	0.005294526	0.001927864	-0.000392073
-0.046723042	1.332934409	-0.000144944	0.005115544	0.003070585	-0.000321822
-0.04298349	1.340205895	-0.002834759	0.005075901	0.004466527	-0.000417118
-0.039243938	1.343765663	-0.006040463	0.00600479	0.005314762	-0.000481472
-0.035504386	1.346458191	-0.005978749	0.008057735	0.009069329	-0.0002282
-0.031764834	1.348203934	-0.005398402	0.010800535	0.01551128	0.000595873
-0.028025282	1.343766348	-0.004069757	0.0141533	0.020495686	0.002345698
-0.02428573	1.332978414	-0.003903595	0.021049004	0.027576721	0.006448853
-0.020546178	1.302675383	-0.00201396	0.033014636	0.037547422	0.013313782
-0.016806626	1.252098796	0.009208601	0.054063247	0.045872856	0.01745912
-0.013067074	1.180285599	0.021407309	0.075175701	0.051505651	0.024939144
-0.009327522	1.08714842	0.032207453	0.101273666	0.061625824	0.035954727
-0.00558797	0.969093869	0.04376598	0.126493337	0.072589039	0.046151297
-0.001848418	0.825969274	0.056140321	0.14680867	0.080277523	0.055018431
0.001891134	0.683011373	0.055059503	0.155675174	0.085950986	0.059698685
0.005630686	0.553105388	0.045778981	0.150463047	0.097490404	0.061725571
0.009370238	0.440625106	0.037230749	0.134530036	0.099694123	0.058191066
0.01310979	0.350977732	0.027165431	0.11415845	0.096573072	0.053667382
0.016849342	0.277133281	0.008756674	0.096044309	0.098374744	0.043618259
0.020588894	0.223709003	-0.014293709	0.08318708	0.100735911	0.033467123
0.024328446	0.187033073	-0.045226737	0.0722462	0.094233767	0.024249567
0.028067998	0.170423448	-0.074620019	0.069468475	0.090845561	0.016793216
0.03180755	0.178828428	-0.083358738	0.071252722	0.089303059	0.007780511
0.035547102	0.190396673	-0.074239935	0.080617551	0.094041342	0.004708013
0.039286654	0.208925107	-0.07843283	0.082723581	0.092887227	0.004345919
0.043026206	0.222960679	-0.056427728	0.082688577	0.058345413	0.000952234
0.05050531	0.271781481	-0.083948916	0.091173672	0.091876628	0.001153354
0.054244862	0.293809755	-0.079245639	0.090618306	0.09108081	0.000808216
0.057984414	0.308942333	-0.049319135	0.089258737	0.074694788	0.004600543
0.061723966	0.202378828	-0.041475049	0.083635529	0.045666678	-0.000930679
0.065463518	-0.32674463	-0.070635862	0.074941505	0.009692831	-0.007211437
0.06920307	-0.403207308	0.005703933	0.06141292	0.036366361	0.006862185

Table VII.6: Experimental data along a vertical line defined at $x = 1.6D$ and $z=0$ [4].

z	U	W	uu	ww	uw
-0.064849161	1.13795496	-0.023221025	0.014044541	0.003286613	0.001093659
-0.061016841	1.244474561	0.028931712	0.00779616	0.001854919	0.000750882
-0.057184521	1.240358061	0.012574452	0.007214413	0.002341483	0.000596236
-0.053352201	1.254985653	0.013146271	0.008490619	0.004348931	0.000733625
-0.049519881	1.263694338	0.013630143	0.00979187	0.007217198	0.000623434
-0.045687561	1.270525964	0.013788982	0.011720505	0.011283437	0.000812327
-0.041855241	1.269726042	0.017565204	0.013170967	0.016514827	0.002780935
-0.038022921	1.261676105	0.021009896	0.017154458	0.020606149	0.006509786
-0.034190601	1.247073416	0.024704287	0.021783436	0.025394146	0.008417038
-0.030358281	1.220727662	0.025552301	0.029600595	0.032008161	0.010696956
-0.026525961	1.183815442	0.027288459	0.038755819	0.038058227	0.014842882
-0.022693641	1.1402731	0.028565516	0.048711293	0.04312766	0.017530434
-0.018861321	1.0880853	0.022380214	0.062010625	0.049957166	0.020923879
-0.015029001	1.032472881	0.019067763	0.073162662	0.055515221	0.025730123
-0.011196681	0.970021553	0.014991577	0.079651538	0.060572618	0.029245822
-0.007364361	0.904516672	0.016115594	0.082356461	0.060930905	0.029971296
-0.003532041	0.848562561	0.018027047	0.081702251	0.064283012	0.029269519
0.000300279	0.807688424	0.015572434	0.07903627	0.06521071	0.027782595
0.004132599	0.766144846	0.007777763	0.074096724	0.064418937	0.026076668
0.007964919	0.730135993	-0.000884641	0.068779029	0.065383609	0.022949421
0.011797239	0.695068572	-0.0100499	0.064745564	0.064528809	0.02056488
0.015629559	0.671260793	-0.017179767	0.062468198	0.065160748	0.014531556
0.019461879	0.654174038	-0.027391057	0.06039031	0.066627987	0.008751327
0.023294199	0.65406777	-0.037502789	0.054817566	0.063877172	0.009278693
0.027126519	0.659236079	-0.042084778	0.054661524	0.064704597	0.004968933
0.030958839	0.668067714	-0.047481811	0.053006221	0.066044694	0.004046325
0.034791158	0.672566687	-0.060068824	0.051855638	0.060156955	-0.00072256
0.038623478	0.683179932	-0.061806909	0.052315479	0.060237999	-0.001485697
0.042455798	0.695455638	-0.04692092	0.05188848	0.066967154	-0.003842083
0.046288118	0.708079991	-0.045423895	0.050782677	0.060418211	-0.001198328
0.050120438	0.719294332	-0.045061921	0.045189539	0.052917085	-0.001165429
0.053952758	0.721841866	-0.034038865	0.053317474	0.045428407	0.000582388
0.057785078	0.713718248	-0.022072876	0.048511619	0.037776053	0.00365118
0.061617398	0.691262241	-0.010542674	0.040146677	0.029209274	0.002803962
0.065449718	0.639828205	-0.006282634	0.043543137	0.019438015	0.004646402
0.069282038	0.594443458	0.000531982	0.052336831	0.016732245	0.00517291

Table VII.7: Experimental data along a vertical line defined at $x = 2.6D$ and $z=0$ [4].

z	U	W	uu	ww	uw
-0.058819134	1.174140906	-0.024960367	0.02015271	0.007043262	-0.001326338
-0.054993342	1.189838388	-0.004860482	0.018008582	0.008696553	0.002206541
-0.05116755	1.197005732	0.024448882	0.01938581	0.012812955	0.004351747
-0.047341757	1.195991102	0.02920367	0.018781665	0.016230602	0.003842177
-0.043515965	1.178911667	0.030656873	0.019342832	0.018075243	0.00467684
-0.039690173	1.165475078	0.031574053	0.020595003	0.019148968	0.006288433
-0.035864381	1.146652721	0.033572284	0.023691164	0.021235466	0.006827855
-0.032038589	1.12487831	0.031554095	0.030465578	0.025109897	0.011265029
-0.028212797	1.100225152	0.027143254	0.034733989	0.028936209	0.013276452
-0.024387005	1.077919913	0.033796561	0.035263865	0.027494393	0.011470188
-0.020561213	1.052692514	0.03302582	0.038390266	0.029364447	0.012493781
-0.016735421	1.027339256	0.030935498	0.040564122	0.031932192	0.012034631
-0.012909629	1.00562469	0.02854156	0.038748064	0.034085697	0.012439064
-0.009083837	0.984463646	0.024639788	0.038563565	0.033372301	0.01359141
-0.005258045	0.963881079	0.024531336	0.04124035	0.036975615	0.014218442
-0.001432253	0.95511166	0.026902799	0.042644081	0.037582754	0.01362075
0.00239354	0.946271224	0.026752756	0.037589378	0.03989348	0.010220166
0.006219332	0.935926102	0.022182644	0.039412686	0.037353247	0.010185531
0.010045124	0.921577914	0.019839273	0.037250313	0.03560414	0.006926185
0.013870916	0.918082949	0.014442475	0.040207378	0.036639478	0.00888558
0.017696708	0.922123174	0.007440122	0.034728224	0.035793072	0.005979122
0.0215225	0.922122291	-0.002295966	0.03033082	0.033744594	0.004045389
0.025348292	0.923916393	-0.009900135	0.030529553	0.035210127	0.004948066
0.029174084	0.922077112	-0.004179909	0.031311266	0.036528363	0.002788234
0.032999876	0.925965744	0.021667536	0.041482848	0.042270421	0.000266185
0.036825668	0.925626562	0.030731423	0.040937297	0.037228858	0.001922627
0.04065146	0.91885609	1.99E-05	0.032916456	0.034077924	0.001892577
0.044477252	0.919770565	-0.005403114	0.028090257	0.028815386	0.00305018
0.048303044	0.904924752	-0.004589232	0.031778399	0.02301714	0.002204115
0.052128836	0.88943742	-0.006831871	0.031342636	0.019446519	0.00275302
0.055954629	0.87238195	-0.008021649	0.025046944	0.016300146	0.003471058
0.059780421	0.845117415	-0.00918554	0.027477551	0.011847637	0.00371154
0.063606213	0.787023619	-0.012831916	0.024701696	0.007277638	0.001211547
0.067432005	0.733229562	-0.025083887	0.03598198	0.008001107	0.001761846

Table VII.8: Experimental data along a vertical line defined at $x = 3.6D$ and $z=0$ [4].

z	U	W	uu	ww	uw
-0.061874809	0.959484147	-0.00803782	0.017808776	0.003799387	-0.001768154
-0.058029305	1.027774842	-0.002837923	0.014724706	0.002785074	-0.000241262
-0.0541838	1.105972039	0.004710245	0.014093984	0.004418722	0.00055353
-0.050338296	1.15261044	0.013032161	0.014477012	0.007530744	0.002085263
-0.046492792	1.173580614	0.017857926	0.015053429	0.008470849	0.003066095
-0.042647288	1.18030621	0.022515622	0.016384305	0.011010336	0.003572255
-0.038801784	1.177434184	0.017314513	0.017625569	0.011834828	0.004653462
-0.027265272	1.14541713	-0.004437967	0.021681239	0.018039813	0.006292412
-0.023419768	1.130980222	0.028418203	0.023028971	0.019095729	0.007555947
-0.019574264	1.112369546	0.037890307	0.023974323	0.02019204	0.007945708
-0.01572876	1.09608106	0.036452997	0.026173637	0.020646666	0.007540846
-0.011883256	1.08397857	0.038556822	0.025435552	0.021035328	0.00746682
-0.008037752	1.067283783	0.039650554	0.02581529	0.022161261	0.00880889
-0.004192248	1.05247221	0.038677725	0.027094948	0.022775288	0.008364076
-0.000346744	1.038556782	0.038038705	0.02862014	0.024613821	0.00845454
0.00349876	1.025708079	0.038537671	0.028215624	0.024290695	0.007877187
0.007344264	1.012486929	0.037074351	0.027543184	0.024125407	0.006198288
0.011189768	0.997577598	0.035321958	0.026326366	0.022751142	0.006809415
0.015035272	0.986295982	0.032245093	0.025199213	0.021961937	0.005710094
0.018880776	0.97682535	0.031515042	0.024631428	0.021822003	0.004751203
0.02272628	0.971966011	0.02796159	0.0252851	0.023665226	0.004191861
0.026571784	0.967849132	0.025452988	0.024542438	0.023711228	0.003596782
0.030417289	0.967755984	0.011373205	0.022727799	0.02425152	0.002176046
0.034262793	0.968542002	0.019260048	0.022228277	0.02254682	0.001481359
0.049644809	0.955932563	0.010731949	0.018758393	0.017270213	0.001404984
0.053490313	0.944472245	0.010614739	0.02119731	0.016755693	0.003961212
0.057335817	0.928999302	0.007730796	0.020028418	0.013481031	0.002399826
0.061181321	0.919018673	-0.000799028	0.019286587	0.011085464	0.002200096
0.065026825	0.90848081	0.001957227	0.019911026	0.009522656	0.002499238
0.068872329	0.845005453	-0.025735644	0.021397975	0.006245586	0.001501816

Table VII.9: Experimental data along a vertical line defined at $x = 4.6D$ and $z=0$ [4].

2 Appendix B – Script SALOME.

```
#!/usr/bin/env python

###
### This file is generated automatically by SALOME v9.3.0 with dump
### python functionality
###

import sys
import salome

salome.salome_init()
import salome_notebook
notebook = salome_notebook.NoteBook()
sys.path.insert(0, r'/home/jo680ben/Mixing-Tee/Mixing-Tee/MESH')

###
### GEOM component
```

###

```

import GEOM
from salome.geom import geomBuilder
import math
import SALOMEDS

geompy = geomBuilder.New()

O = geompy.MakeVertex(0, 0, 0)
OX = geompy.MakeVectorDXDYDZ(1, 0, 0)
OY = geompy.MakeVectorDXDYDZ(0, 1, 0)
OZ = geompy.MakeVectorDXDYDZ(0, 0, 1)
geomObj_1 = geompy.MakeVertex(0, 0, 0)
geomObj_2 = geompy.MakeVectorDXDYDZ(1, 0, 0)
geomObj_3 = geompy.MakeVectorDXDYDZ(0, 1, 0)
geomObj_4 = geompy.MakeVectorDXDYDZ(0, 0, 1)
geomObj_5 = geompy.MakeVertex(0, 0, 0)
geomObj_6 = geompy.MakeVectorDXDYDZ(1, 0, 0)
geomObj_7 = geompy.MakeVectorDXDYDZ(0, 1, 0)
geomObj_8 = geompy.MakeVectorDXDYDZ(0, 0, 1)
geomObj_9 = geompy.MakeVertex(0, 0, 0)
geomObj_10 = geompy.MakeVectorDXDYDZ(1, 0, 0)
geomObj_11 = geompy.MakeVectorDXDYDZ(0, 1, 0)
geomObj_12 = geompy.MakeVectorDXDYDZ(0, 0, 1)
geomObj_13 = geompy.MakeVertex(0, 0, 0)
geomObj_14 = geompy.MakeVertex(0, 0.070000000000000001, 0)
geomObj_15 = geompy.MakeVertex(0, 0.14, 0)
geomObj_16 = geompy.MakeLineTwoPnt(geomObj_14, geomObj_15)
geomObj_17 = geompy.MakeRotation(geomObj_16, geomObj_10, 45*math.pi
    /180.0)
geomObj_18 = geompy.MakeRotation(geomObj_14, geomObj_10, 45*math.pi
    /180.0)
geomObj_19 = geompy.MakeRotation(geomObj_15, geomObj_10, 45*math.pi
    /180.0)
geomObj_20 = geompy.MakeVertex(0, -0.070000000000000001, 0)
geomObj_21 = geompy.MakeVertex(0, -0.14, 0)
geomObj_22 = geompy.MakeLineTwoPnt(geomObj_20, geomObj_21)
geomObj_23 = geompy.MakeRotation(geomObj_22, geomObj_10, -45*math.pi
    /180.0)
geomObj_24 = geompy.MakeRotation(geomObj_20, geomObj_10, -45*math.pi
    /180.0)
geomObj_25 = geompy.MakeRotation(geomObj_21, geomObj_10, -45*math.pi
    /180.0)
geomObj_26 = geompy.MakeLineTwoPnt(geomObj_18, geomObj_24)
geomObj_27 = geompy.MakeLineTwoPnt(geomObj_14, geomObj_18)
geomObj_28 = geompy.MakeLineTwoPnt(geomObj_20, geomObj_24)
geomObj_29 = geompy.MakeVertex(0, 0, 0.14)
geomObj_30 = geompy.MakeArc(geomObj_15, geomObj_29, geomObj_21)
geomObj_31 = geompy.MakeLineTwoPnt(geomObj_15, geomObj_21)
geomObj_32 = geompy.MakeFaceWires([geomObj_30, geomObj_31], 1)
geomObj_33 = geompy.MakePartition([geomObj_32], [geomObj_17, geomObj_23,
    geomObj_26, geomObj_27, geomObj_28], [], [], geompy.ShapeType["FACE"],
    0, [], 0)

```

EDF R&D	code_saturne version 8.0 tutorial: Turbulence simulation in a mixing tee	code_saturne documentation Page 56/127
---------	---	--

```

geomObj_34 = geompy.MakeVertex(0, 0, 0)
geomObj_35 = geompy.MakeVectorDXDYDZ(1, 0, 0)
geomObj_36 = geompy.MakeVectorDXDYDZ(0, 1, 0)
geomObj_37 = geompy.MakeVectorDXDYDZ(0, 0, 1)
geomObj_38 = geompy.MakeVertex(0, 0, 0)
geomObj_39 = geompy.MakeVertex(0, 0.05, 0)
geomObj_40 = geompy.MakeVertex(0, 0.1, 0)
geomObj_41 = geompy.MakeLineTwoPnt(geomObj_39, geomObj_40)
geomObj_42 = geompy.MakeRotation(geomObj_41, geomObj_35, 45*math.pi
    /180.0)
geomObj_43 = geompy.MakeRotation(geomObj_39, geomObj_35, 45*math.pi
    /180.0)
geomObj_44 = geompy.MakeRotation(geomObj_40, geomObj_35, 45*math.pi
    /180.0)
geomObj_45 = geompy.MakeVertex(0, -0.05, 0)
geomObj_46 = geompy.MakeVertex(0, -0.1, 0)
geomObj_47 = geompy.MakeLineTwoPnt(geomObj_45, geomObj_46)
geomObj_48 = geompy.MakeRotation(geomObj_47, geomObj_35, -45*math.pi
    /180.0)
geomObj_49 = geompy.MakeRotation(geomObj_45, geomObj_35, -45*math.pi
    /180.0)
geomObj_50 = geompy.MakeRotation(geomObj_46, geomObj_35, -45*math.pi
    /180.0)
geomObj_51 = geompy.MakeLineTwoPnt(geomObj_43, geomObj_49)
geomObj_52 = geompy.MakeLineTwoPnt(geomObj_39, geomObj_43)
geomObj_53 = geompy.MakeLineTwoPnt(geomObj_45, geomObj_49)
geomObj_54 = geompy.MakeVertex(0, 0, 0.1)
geomObj_55 = geompy.MakeArc(geomObj_40, geomObj_54, geomObj_46)
geomObj_56 = geompy.MakeLineTwoPnt(geomObj_40, geomObj_46)
geomObj_57 = geompy.MakeFaceWires([geomObj_55, geomObj_56], 1)
geomObj_58 = geompy.MakePartition([geomObj_57], [geomObj_42, geomObj_48,
    geomObj_51, geomObj_52, geomObj_53], [], [], geompy.ShapeType["FACE"],
    0, [], 0)
geomObj_59 = geompy.MakeRotation(geomObj_39, geomObj_36, 90*math.pi
    /180.0)
geomObj_60 = geompy.MakeRotation(geomObj_40, geomObj_36, 90*math.pi
    /180.0)
geomObj_61 = geompy.MakeRotation(geomObj_45, geomObj_36, 90*math.pi
    /180.0)
geomObj_62 = geompy.MakeRotation(geomObj_46, geomObj_36, 90*math.pi
    /180.0)
geomObj_63 = geompy.MakeRotation(geomObj_43, geomObj_36, 90*math.pi
    /180.0)
geomObj_64 = geompy.MakeRotation(geomObj_49, geomObj_36, 90*math.pi
    /180.0)
geomObj_65 = geompy.MakeRotation(geomObj_44, geomObj_36, 90*math.pi
    /180.0)
geomObj_66 = geompy.MakeRotation(geomObj_50, geomObj_36, 90*math.pi
    /180.0)
geomObj_67 = geompy.MakeRotation(geomObj_56, geomObj_36, 90*math.pi
    /180.0)
geomObj_68 = geompy.MakeRotation(geomObj_41, geomObj_36, 90*math.pi
    /180.0)
geomObj_69 = geompy.MakeRotation(geomObj_42, geomObj_36, 90*math.pi
    /180.0)

```

EDF R&D	code_saturne version 8.0 tutorial: Turbulence simulation in a mixing tee	code_saturne documentation Page 57/127
---------	---	--

```

geomObj_70 = geompy.MakeRotation(geomObj_47, geomObj_36, 90*math.pi
    /180.0)
geomObj_71 = geompy.MakeRotation(geomObj_48, geomObj_36, 90*math.pi
    /180.0)
geomObj_72 = geompy.MakeRotation(geomObj_51, geomObj_36, 90*math.pi
    /180.0)
geomObj_73 = geompy.MakeRotation(geomObj_52, geomObj_36, 90*math.pi
    /180.0)
geomObj_74 = geompy.MakeRotation(geomObj_53, geomObj_36, 90*math.pi
    /180.0)
geomObj_75 = geompy.MakeRotation(geomObj_55, geomObj_36, 90*math.pi
    /180.0)
geomObj_76 = geompy.MakeRotation(geomObj_58, geomObj_36, 90*math.pi
    /180.0)
geomObj_77 = geompy.MakePrismVecH(geomObj_33, geomObj_6, 0.28)
geomObj_78 = geompy.MakePrismVecH(geomObj_76, geomObj_8, 0.14)
geomObj_79 = geompy.MakePrismVecH(geomObj_30, geomObj_6, 0.28)
geomObj_80 = geompy.MakePlane(geomObj_5, geomObj_6, 0.5600000000000001)
geomObj_81 = geompy.MakeRotation(geomObj_80, geomObj_7, 45*math.pi/180.0)
geomObj_82 = geompy.MakeCommonList([geomObj_77, geomObj_81], True)
[geomObj_83, geomObj_84, geomObj_85, geomObj_86, geomObj_87, geomObj_88,
    geomObj_89, geomObj_90] = geompy.ExtractShapes(geomObj_82, geompy.
    ShapeType["VERTEX"], True)
[geomObj_91, geomObj_92, geomObj_93, geomObj_94, geomObj_95, geomObj_96,
    geomObj_97, geomObj_98, geomObj_99, geomObj_100, geomObj_101] = geompy.
    ExtractShapes(geomObj_82, geompy.ShapeType["EDGE"], True)
[geomObj_102, geomObj_103] = geompy.ExtractShapes(geomObj_91, geompy.
    ShapeType["VERTEX"], True)
[geomObj_104, geomObj_105] = geompy.ExtractShapes(geomObj_91, geompy.
    ShapeType["VERTEX"], True)
[geomObj_106, geomObj_107] = geompy.ExtractShapes(geomObj_91, geompy.
    ShapeType["VERTEX"], True)
[geomObj_108, geomObj_109] = geompy.ExtractShapes(geomObj_92, geompy.
    ShapeType["VERTEX"], True)
[geomObj_110, geomObj_111] = geompy.ExtractShapes(geomObj_92, geompy.
    ShapeType["VERTEX"], True)
[geomObj_112, geomObj_113] = geompy.ExtractShapes(geomObj_92, geompy.
    ShapeType["VERTEX"], True)
[geomObj_114, geomObj_115] = geompy.ExtractShapes(geomObj_93, geompy.
    ShapeType["VERTEX"], True)
[geomObj_116, geomObj_117] = geompy.ExtractShapes(geomObj_93, geompy.
    ShapeType["VERTEX"], True)
[geomObj_118, geomObj_119] = geompy.ExtractShapes(geomObj_93, geompy.
    ShapeType["VERTEX"], True)
[geomObj_120, geomObj_121] = geompy.ExtractShapes(geomObj_94, geompy.
    ShapeType["VERTEX"], True)
[geomObj_122, geomObj_123] = geompy.ExtractShapes(geomObj_94, geompy.
    ShapeType["VERTEX"], True)
[geomObj_124, geomObj_125] = geompy.ExtractShapes(geomObj_94, geompy.
    ShapeType["VERTEX"], True)
[geomObj_126, geomObj_127] = geompy.ExtractShapes(geomObj_95, geompy.
    ShapeType["VERTEX"], True)
[geomObj_128, geomObj_129] = geompy.ExtractShapes(geomObj_95, geompy.
    ShapeType["VERTEX"], True)

```

```

[geomObj_130,geomObj_131] = geompy.ExtractShapes(geomObj_95, geompy.
    ShapeType["VERTEX"], True)
[geomObj_132,geomObj_133] = geompy.ExtractShapes(geomObj_96, geompy.
    ShapeType["VERTEX"], True)
[geomObj_134,geomObj_135] = geompy.ExtractShapes(geomObj_96, geompy.
    ShapeType["VERTEX"], True)
[geomObj_136,geomObj_137] = geompy.ExtractShapes(geomObj_96, geompy.
    ShapeType["VERTEX"], True)
[geomObj_138,geomObj_139] = geompy.ExtractShapes(geomObj_97, geompy.
    ShapeType["VERTEX"], True)
[geomObj_140,geomObj_141] = geompy.ExtractShapes(geomObj_97, geompy.
    ShapeType["VERTEX"], True)
[geomObj_142,geomObj_143] = geompy.ExtractShapes(geomObj_98, geompy.
    ShapeType["VERTEX"], True)
[geomObj_144,geomObj_145] = geompy.ExtractShapes(geomObj_98, geompy.
    ShapeType["VERTEX"], True)
[geomObj_146,geomObj_147] = geompy.ExtractShapes(geomObj_99, geompy.
    ShapeType["VERTEX"], True)
[geomObj_148,geomObj_149] = geompy.ExtractShapes(geomObj_100, geompy.
    ShapeType["VERTEX"], True)
[geomObj_150,geomObj_151] = geompy.ExtractShapes(geomObj_101, geompy.
    ShapeType["VERTEX"], True)
geomObj_152 = geompy.MakeCommonList([geomObj_78, geomObj_79], True)
[geomObj_153,geomObj_154,geomObj_155,geomObj_156,geomObj_157,geomObj_158,
    geomObj_159,geomObj_160,geomObj_161,geomObj_162,geomObj_163] = geompy.
    ExtractShapes(geomObj_152, geompy.ShapeType["VERTEX"], True)
[geomObj_164,geomObj_165,geomObj_166,geomObj_167,geomObj_168,geomObj_169,
    geomObj_170,geomObj_171,geomObj_172,geomObj_173,geomObj_174,
    geomObj_175,geomObj_176,geomObj_177,geomObj_178,geomObj_179] = geompy.
    ExtractShapes(geomObj_152, geompy.ShapeType["EDGE"], True)
[geomObj_180,geomObj_181] = geompy.ExtractShapes(geomObj_164, geompy.
    ShapeType["VERTEX"], True)
[geomObj_182,geomObj_183] = geompy.ExtractShapes(geomObj_164, geompy.
    ShapeType["VERTEX"], True)
[geomObj_184,geomObj_185] = geompy.ExtractShapes(geomObj_164, geompy.
    ShapeType["VERTEX"], True)
[geomObj_186,geomObj_187] = geompy.ExtractShapes(geomObj_165, geompy.
    ShapeType["VERTEX"], True)
[geomObj_188,geomObj_189] = geompy.ExtractShapes(geomObj_165, geompy.
    ShapeType["VERTEX"], True)
[geomObj_190,geomObj_191] = geompy.ExtractShapes(geomObj_165, geompy.
    ShapeType["VERTEX"], True)
[geomObj_192,geomObj_193] = geompy.ExtractShapes(geomObj_166, geompy.
    ShapeType["VERTEX"], True)
[geomObj_194,geomObj_195] = geompy.ExtractShapes(geomObj_166, geompy.
    ShapeType["VERTEX"], True)
[geomObj_196,geomObj_197] = geompy.ExtractShapes(geomObj_166, geompy.
    ShapeType["VERTEX"], True)
[geomObj_198,geomObj_199] = geompy.ExtractShapes(geomObj_167, geompy.
    ShapeType["VERTEX"], True)
[geomObj_200,geomObj_201] = geompy.ExtractShapes(geomObj_167, geompy.
    ShapeType["VERTEX"], True)
[geomObj_202,geomObj_203] = geompy.ExtractShapes(geomObj_167, geompy.
    ShapeType["VERTEX"], True)

```

EDF R&D	code_saturne version 8.0 tutorial: Turbulence simulation in a mixing tee	code_saturne documentation Page 59/127
---------	---	--

```

[geomObj_204,geomObj_205] = geompy.ExtractShapes(geomObj_168, geompy.
    ShapeType["VERTEX"], True)
[geomObj_206,geomObj_207] = geompy.ExtractShapes(geomObj_168, geompy.
    ShapeType["VERTEX"], True)
[geomObj_208,geomObj_209] = geompy.ExtractShapes(geomObj_168, geompy.
    ShapeType["VERTEX"], True)
[geomObj_210,geomObj_211] = geompy.ExtractShapes(geomObj_169, geompy.
    ShapeType["VERTEX"], True)
[geomObj_212,geomObj_213] = geompy.ExtractShapes(geomObj_169, geompy.
    ShapeType["VERTEX"], True)
[geomObj_214,geomObj_215] = geompy.ExtractShapes(geomObj_169, geompy.
    ShapeType["VERTEX"], True)
[geomObj_216,geomObj_217] = geompy.ExtractShapes(geomObj_170, geompy.
    ShapeType["VERTEX"], True)
[geomObj_218,geomObj_219] = geompy.ExtractShapes(geomObj_170, geompy.
    ShapeType["VERTEX"], True)
[geomObj_220,geomObj_221] = geompy.ExtractShapes(geomObj_170, geompy.
    ShapeType["VERTEX"], True)
[geomObj_222,geomObj_223] = geompy.ExtractShapes(geomObj_171, geompy.
    ShapeType["VERTEX"], True)
[geomObj_224,geomObj_225] = geompy.ExtractShapes(geomObj_171, geompy.
    ShapeType["VERTEX"], True)
[geomObj_226,geomObj_227] = geompy.ExtractShapes(geomObj_171, geompy.
    ShapeType["VERTEX"], True)
[geomObj_228,geomObj_229] = geompy.ExtractShapes(geomObj_172, geompy.
    ShapeType["VERTEX"], True)
[geomObj_230,geomObj_231] = geompy.ExtractShapes(geomObj_172, geompy.
    ShapeType["VERTEX"], True)
[geomObj_232,geomObj_233] = geompy.ExtractShapes(geomObj_173, geompy.
    ShapeType["VERTEX"], True)
[geomObj_234,geomObj_235] = geompy.ExtractShapes(geomObj_173, geompy.
    ShapeType["VERTEX"], True)
[geomObj_236,geomObj_237] = geompy.ExtractShapes(geomObj_174, geompy.
    ShapeType["VERTEX"], True)
[geomObj_238,geomObj_239] = geompy.ExtractShapes(geomObj_174, geompy.
    ShapeType["VERTEX"], True)
[geomObj_240,geomObj_241] = geompy.ExtractShapes(geomObj_175, geompy.
    ShapeType["VERTEX"], True)
[geomObj_242,geomObj_243] = geompy.ExtractShapes(geomObj_176, geompy.
    ShapeType["VERTEX"], True)
[geomObj_244,geomObj_245] = geompy.ExtractShapes(geomObj_177, geompy.
    ShapeType["VERTEX"], True)
[geomObj_246,geomObj_247] = geompy.ExtractShapes(geomObj_178, geompy.
    ShapeType["VERTEX"], True)
[geomObj_248,geomObj_249] = geompy.ExtractShapes(geomObj_179, geompy.
    ShapeType["VERTEX"], True)
geomObj_250 = geompy.MakePlaneThreePnt(geomObj_14, geomObj_15, geomObj_25
    , 10000)
geomObj_251 = geompy.MakeProjection(geomObj_83, geomObj_250)
geomObj_252 = geompy.MakeProjection(geomObj_84, geomObj_250)
geomObj_253 = geompy.MakeProjection(geomObj_85, geomObj_250)
geomObj_254 = geompy.MakeProjection(geomObj_86, geomObj_250)
geomObj_255 = geompy.MakeProjection(geomObj_87, geomObj_250)
geomObj_256 = geompy.MakeProjection(geomObj_88, geomObj_250)
geomObj_257 = geompy.MakeProjection(geomObj_89, geomObj_250)

```

EDF R&D	code_saturne version 8.0 tutorial: Turbulence simulation in a mixing tee	code_saturne documentation Page 60/127
---------	---	--

```

geomObj_258 = geompy.MakeProjection(geomObj_90, geomObj_250)
geomObj_259 = geompy.MakePlaneThreePnt(geomObj_59, geomObj_60, geomObj_66
, 10000)
geomObj_260 = geompy.MakeProjection(geomObj_153, geomObj_259)
geomObj_261 = geompy.MakeProjection(geomObj_154, geomObj_259)
geomObj_262 = geompy.MakeProjection(geomObj_155, geomObj_259)
geomObj_263 = geompy.MakeProjection(geomObj_156, geomObj_259)
geomObj_264 = geompy.MakeProjection(geomObj_157, geomObj_259)
geomObj_265 = geompy.MakeProjection(geomObj_158, geomObj_259)
geomObj_266 = geompy.MakeProjection(geomObj_159, geomObj_259)
geomObj_267 = geompy.MakeProjection(geomObj_160, geomObj_259)
geomObj_268 = geompy.MakeProjection(geomObj_161, geomObj_259)
geomObj_269 = geompy.MakeProjection(geomObj_162, geomObj_259)
geomObj_270 = geompy.MakeProjection(geomObj_163, geomObj_259)
geomObj_271 = geompy.MakeTranslation(geomObj_156, 0, 0, -0.05)
geomObj_272 = geompy.MakeTranslation(geomObj_154, 0, 0, -0.05)
geomObj_273 = geompy.MakeTranslation(geomObj_160, 0, 0, -0.05)
geomObj_274 = geompy.MakeTranslation(geomObj_158, 0, 0, -0.05)
geomObj_275 = geompy.MakeArcCenter(geomObj_5, geomObj_157, geomObj_86,
False)
geomObj_276 = geompy.MakeArcCenter(geomObj_5, geomObj_153, geomObj_83,
False)
geomObj_277 = geompy.MakePlaneThreePnt(geomObj_162, geomObj_90,
geomObj_88, 10000)
geomObj_278 = geompy.MakeSection(geomObj_277, geomObj_79, True)
geomObj_279 = geompy.MakePartition([geomObj_278], [geomObj_82,
geomObj_152], [], [], geompy.ShapeType["EDGE"], 0, [], 0)
[geomObj_280, geomObj_281, geomObj_282, geomObj_283] = geompy.ExtractShapes(
geomObj_279, geompy.ShapeType["EDGE"], True)
[geomObj_284, geomObj_285] = geompy.ExtractShapes(geomObj_280, geompy.
ShapeType["VERTEX"], True)
[geomObj_286, geomObj_287] = geompy.ExtractShapes(geomObj_281, geompy.
ShapeType["VERTEX"], True)
[geomObj_288, geomObj_289] = geompy.ExtractShapes(geomObj_282, geompy.
ShapeType["VERTEX"], True)
geomObj_290 = geompy.MakePlaneThreePnt(geomObj_161, geomObj_89,
geomObj_87, 10000)
geomObj_291 = geompy.MakeSection(geomObj_290, geomObj_79, True)
geomObj_292 = geompy.MakePartition([geomObj_291], [geomObj_82,
geomObj_152], [], [], geompy.ShapeType["EDGE"], 0, [], 0)
[geomObj_293, geomObj_294, geomObj_295, geomObj_296] = geompy.ExtractShapes(
geomObj_292, geompy.ShapeType["EDGE"], True)
[geomObj_297, geomObj_298] = geompy.ExtractShapes(geomObj_293, geompy.
ShapeType["VERTEX"], True)
[geomObj_299, geomObj_300] = geompy.ExtractShapes(geomObj_294, geompy.
ShapeType["VERTEX"], True)
[geomObj_301, geomObj_302] = geompy.ExtractShapes(geomObj_295, geompy.
ShapeType["VERTEX"], True)
geomObj_303 = geompy.MakeLineTwoPnt(geomObj_85, geomObj_271)
geomObj_304 = geompy.MakeLineTwoPnt(geomObj_84, geomObj_272)
geomObj_305 = geompy.MakeLineTwoPnt(geomObj_88, geomObj_273)
geomObj_306 = geompy.MakeLineTwoPnt(geomObj_87, geomObj_274)
geomObj_307 = geompy.MakeLineTwoPnt(geomObj_85, geomObj_84)
geomObj_308 = geompy.MakeLineTwoPnt(geomObj_85, geomObj_86)
geomObj_309 = geompy.MakeLineTwoPnt(geomObj_88, geomObj_90)

```

EDF R&D	code_saturne version 8.0 tutorial: Turbulence simulation in a mixing tee	code_saturne documentation Page 61/127
---------	---	--

```

geomObj_310 = geompy.MakeLineTwoPnt(geomObj_84, geomObj_83)
geomObj_311 = geompy.MakeLineTwoPnt(geomObj_87, geomObj_89)
geomObj_312 = geompy.MakeLineTwoPnt(geomObj_88, geomObj_87)
geomObj_313 = geompy.MakeLineTwoPnt(geomObj_85, geomObj_88)
geomObj_314 = geompy.MakeLineTwoPnt(geomObj_84, geomObj_87)
geomObj_315 = geompy.MakeLineTwoPnt(geomObj_271, geomObj_272)
geomObj_316 = geompy.MakeLineTwoPnt(geomObj_271, geomObj_157)
geomObj_317 = geompy.MakeLineTwoPnt(geomObj_273, geomObj_162)
geomObj_318 = geompy.MakeLineTwoPnt(geomObj_272, geomObj_153)
geomObj_319 = geompy.MakeLineTwoPnt(geomObj_274, geomObj_161)
geomObj_320 = geompy.MakeLineTwoPnt(geomObj_273, geomObj_274)
geomObj_321 = geompy.MakeLineTwoPnt(geomObj_271, geomObj_273)
geomObj_322 = geompy.MakeLineTwoPnt(geomObj_272, geomObj_274)
geomObj_323 = geompy.MakeFaceWires([geomObj_313, geomObj_303, geomObj_321
, geomObj_305], 0)
geomObj_324 = geompy.MakeFaceWires([geomObj_314, geomObj_304, geomObj_322
, geomObj_306], 0)
geomObj_325 = geompy.MakeFaceWires([geomObj_309, geomObj_305, geomObj_317
, geomObj_282], 0)
geomObj_326 = geompy.MakeFaceWires([geomObj_312, geomObj_305, geomObj_320
, geomObj_306], 0)
geomObj_327 = geompy.MakeFaceWires([geomObj_311, geomObj_306, geomObj_319
, geomObj_295], 0)
geomObj_328 = geompy.MakeFaceWires([geomObj_315, geomObj_321, geomObj_320
, geomObj_322], 0)
geomObj_329 = geompy.MakeFaceWires([geomObj_316, geomObj_321, geomObj_317
, geomObj_174], 0)
geomObj_330 = geompy.MakeVertex(0, 0, 0)
geomObj_331 = geompy.MakeVectorDXDYDZ(1, 0, 0)
geomObj_332 = geompy.MakeVectorDXDYDZ(0, 1, 0)
geomObj_333 = geompy.MakeVectorDXDYDZ(0, 0, 1)
geomObj_334 = geompy.MakeVertex(0, 0, 0)
geomObj_335 = geompy.MakeVectorDXDYDZ(1, 0, 0)
geomObj_336 = geompy.MakeVectorDXDYDZ(0, 1, 0)
geomObj_337 = geompy.MakeVectorDXDYDZ(0, 0, 1)
geomObj_338 = geompy.MakeVertex(0, 0, 0)
geomObj_339 = geompy.MakeVectorDXDYDZ(1, 0, 0)
geomObj_340 = geompy.MakeVectorDXDYDZ(0, 1, 0)
geomObj_341 = geompy.MakeVectorDXDYDZ(0, 0, 1)
geomObj_342 = geompy.MakeVertex(0, 0, 0)
geomObj_343 = geompy.MakeVertex(0, 0.070000000000000001, 0)
geomObj_344 = geompy.MakeVertex(0, 0.14, 0)
geomObj_345 = geompy.MakeLineTwoPnt(geomObj_343, geomObj_344)
geomObj_346 = geompy.MakeRotation(geomObj_345, geomObj_339, 45*math.pi
/180.0)
geomObj_347 = geompy.MakeRotation(geomObj_343, geomObj_339, 45*math.pi
/180.0)
geomObj_348 = geompy.MakeRotation(geomObj_344, geomObj_339, 45*math.pi
/180.0)
geomObj_349 = geompy.MakeVertex(0, -0.070000000000000001, 0)
geomObj_350 = geompy.MakeVertex(0, -0.14, 0)
geomObj_351 = geompy.MakeLineTwoPnt(geomObj_349, geomObj_350)
geomObj_352 = geompy.MakeRotation(geomObj_351, geomObj_339, -45*math.pi
/180.0)

```

EDF R&D	code_saturne version 8.0 tutorial: Turbulence simulation in a mixing tee	code_saturne documentation Page 62/127
---------	---	--

```

geomObj_353 = geompy.MakeRotation(geomObj_349, geomObj_339, -45*math.pi
/180.0)
geomObj_354 = geompy.MakeRotation(geomObj_350, geomObj_339, -45*math.pi
/180.0)
geomObj_355 = geompy.MakeLineTwoPnt(geomObj_347, geomObj_353)
geomObj_356 = geompy.MakeLineTwoPnt(geomObj_343, geomObj_347)
geomObj_357 = geompy.MakeLineTwoPnt(geomObj_349, geomObj_353)
geomObj_358 = geompy.MakeVertex(0, 0, 0.14)
geomObj_359 = geompy.MakeArc(geomObj_344, geomObj_358, geomObj_350)
geomObj_360 = geompy.MakeLineTwoPnt(geomObj_344, geomObj_350)
geomObj_361 = geompy.MakeFaceWires([geomObj_359, geomObj_360], 1)
geomObj_362 = geompy.MakePartition([geomObj_361], [geomObj_346,
geomObj_352, geomObj_355, geomObj_356, geomObj_357], [], [], geompy.
ShapeType["FACE"], 0, [], 0)
geomObj_363 = geompy.MakeVertex(0, 0, 0)
geomObj_364 = geompy.MakeVectorDXDYDZ(1, 0, 0)
geomObj_365 = geompy.MakeVectorDXDYDZ(0, 1, 0)
geomObj_366 = geompy.MakeVectorDXDYDZ(0, 0, 1)
geomObj_367 = geompy.MakeVertex(0, 0, 0)
geomObj_368 = geompy.MakeVertex(0, 0.05, 0)
geomObj_369 = geompy.MakeVertex(0, 0.1, 0)
geomObj_370 = geompy.MakeLineTwoPnt(geomObj_368, geomObj_369)
geomObj_371 = geompy.MakeRotation(geomObj_370, geomObj_364, 45*math.pi
/180.0)
geomObj_372 = geompy.MakeRotation(geomObj_368, geomObj_364, 45*math.pi
/180.0)
geomObj_373 = geompy.MakeRotation(geomObj_369, geomObj_364, 45*math.pi
/180.0)
geomObj_374 = geompy.MakeVertex(0, -0.05, 0)
geomObj_375 = geompy.MakeVertex(0, -0.1, 0)
geomObj_376 = geompy.MakeLineTwoPnt(geomObj_374, geomObj_375)
geomObj_377 = geompy.MakeRotation(geomObj_376, geomObj_364, -45*math.pi
/180.0)
geomObj_378 = geompy.MakeRotation(geomObj_374, geomObj_364, -45*math.pi
/180.0)
geomObj_379 = geompy.MakeRotation(geomObj_375, geomObj_364, -45*math.pi
/180.0)
geomObj_380 = geompy.MakeLineTwoPnt(geomObj_372, geomObj_378)
geomObj_381 = geompy.MakeLineTwoPnt(geomObj_368, geomObj_372)
geomObj_382 = geompy.MakeLineTwoPnt(geomObj_374, geomObj_378)
geomObj_383 = geompy.MakeVertex(0, 0, 0.1)
geomObj_384 = geompy.MakeArc(geomObj_369, geomObj_383, geomObj_375)
geomObj_385 = geompy.MakeLineTwoPnt(geomObj_369, geomObj_375)
geomObj_386 = geompy.MakeFaceWires([geomObj_384, geomObj_385], 1)
geomObj_387 = geompy.MakePartition([geomObj_386], [geomObj_371,
geomObj_377, geomObj_380, geomObj_381, geomObj_382], [], [], geompy.
ShapeType["FACE"], 0, [], 0)
geomObj_388 = geompy.MakeRotation(geomObj_368, geomObj_365, 90*math.pi
/180.0)
geomObj_389 = geompy.MakeRotation(geomObj_369, geomObj_365, 90*math.pi
/180.0)
geomObj_390 = geompy.MakeRotation(geomObj_374, geomObj_365, 90*math.pi
/180.0)
geomObj_391 = geompy.MakeRotation(geomObj_375, geomObj_365, 90*math.pi
/180.0)

```

```

geomObj_392 = geompy.MakeRotation(geomObj_372, geomObj_365, 90*math.pi
    /180.0)
geomObj_393 = geompy.MakeRotation(geomObj_378, geomObj_365, 90*math.pi
    /180.0)
geomObj_394 = geompy.MakeRotation(geomObj_373, geomObj_365, 90*math.pi
    /180.0)
geomObj_395 = geompy.MakeRotation(geomObj_379, geomObj_365, 90*math.pi
    /180.0)
geomObj_396 = geompy.MakeRotation(geomObj_385, geomObj_365, 90*math.pi
    /180.0)
geomObj_397 = geompy.MakeRotation(geomObj_370, geomObj_365, 90*math.pi
    /180.0)
geomObj_398 = geompy.MakeRotation(geomObj_371, geomObj_365, 90*math.pi
    /180.0)
geomObj_399 = geompy.MakeRotation(geomObj_376, geomObj_365, 90*math.pi
    /180.0)
geomObj_400 = geompy.MakeRotation(geomObj_377, geomObj_365, 90*math.pi
    /180.0)
geomObj_401 = geompy.MakeRotation(geomObj_380, geomObj_365, 90*math.pi
    /180.0)
geomObj_402 = geompy.MakeRotation(geomObj_381, geomObj_365, 90*math.pi
    /180.0)
geomObj_403 = geompy.MakeRotation(geomObj_382, geomObj_365, 90*math.pi
    /180.0)
geomObj_404 = geompy.MakeRotation(geomObj_384, geomObj_365, 90*math.pi
    /180.0)
geomObj_405 = geompy.MakeRotation(geomObj_387, geomObj_365, 90*math.pi
    /180.0)
geomObj_406 = geompy.MakePrismVecH(geomObj_362, geomObj_335, 0.28)
geomObj_407 = geompy.MakePrismVecH(geomObj_405, geomObj_337, 0.14)
geomObj_408 = geompy.MakePrismVecH(geomObj_359, geomObj_335, 0.28)
geomObj_409 = geompy.MakePlane(geomObj_334, geomObj_335,
    0.56000000000000001)
geomObj_410 = geompy.MakeRotation(geomObj_409, geomObj_336, 45*math.pi
    /180.0)
geomObj_411 = geompy.MakeCommonList([geomObj_406, geomObj_410], True)
[geomObj_412, geomObj_413, geomObj_414, geomObj_415, geomObj_416, geomObj_417,
    geomObj_418, geomObj_419] = geompy.ExtractShapes(geomObj_411, geompy.
    ShapeType["VERTEX"], True)
[geomObj_420, geomObj_421, geomObj_422, geomObj_423, geomObj_424, geomObj_425,
    geomObj_426, geomObj_427, geomObj_428, geomObj_429, geomObj_430] = geompy.
    ExtractShapes(geomObj_411, geompy.ShapeType["EDGE"], True)
[geomObj_431, geomObj_432] = geompy.ExtractShapes(geomObj_420, geompy.
    ShapeType["VERTEX"], True)
[geomObj_433, geomObj_434] = geompy.ExtractShapes(geomObj_420, geompy.
    ShapeType["VERTEX"], True)
[geomObj_435, geomObj_436] = geompy.ExtractShapes(geomObj_420, geompy.
    ShapeType["VERTEX"], True)
[geomObj_437, geomObj_438] = geompy.ExtractShapes(geomObj_421, geompy.
    ShapeType["VERTEX"], True)
[geomObj_439, geomObj_440] = geompy.ExtractShapes(geomObj_421, geompy.
    ShapeType["VERTEX"], True)
[geomObj_441, geomObj_442] = geompy.ExtractShapes(geomObj_421, geompy.
    ShapeType["VERTEX"], True)

```

EDF R&D	code_saturne version 8.0 tutorial: Turbulence simulation in a mixing tee	code_saturne documentation Page 64/127
---------	---	--

```

[geomObj_443,geomObj_444] = geompy.ExtractShapes(geomObj_422, geompy.
  ShapeType["VERTEX"], True)
[geomObj_445,geomObj_446] = geompy.ExtractShapes(geomObj_422, geompy.
  ShapeType["VERTEX"], True)
[geomObj_447,geomObj_448] = geompy.ExtractShapes(geomObj_422, geompy.
  ShapeType["VERTEX"], True)
[geomObj_449,geomObj_450] = geompy.ExtractShapes(geomObj_423, geompy.
  ShapeType["VERTEX"], True)
[geomObj_451,geomObj_452] = geompy.ExtractShapes(geomObj_423, geompy.
  ShapeType["VERTEX"], True)
[geomObj_453,geomObj_454] = geompy.ExtractShapes(geomObj_423, geompy.
  ShapeType["VERTEX"], True)
[geomObj_455,geomObj_456] = geompy.ExtractShapes(geomObj_424, geompy.
  ShapeType["VERTEX"], True)
[geomObj_457,geomObj_458] = geompy.ExtractShapes(geomObj_424, geompy.
  ShapeType["VERTEX"], True)
[geomObj_459,geomObj_460] = geompy.ExtractShapes(geomObj_424, geompy.
  ShapeType["VERTEX"], True)
[geomObj_461,geomObj_462] = geompy.ExtractShapes(geomObj_425, geompy.
  ShapeType["VERTEX"], True)
[geomObj_463,geomObj_464] = geompy.ExtractShapes(geomObj_425, geompy.
  ShapeType["VERTEX"], True)
[geomObj_465,geomObj_466] = geompy.ExtractShapes(geomObj_425, geompy.
  ShapeType["VERTEX"], True)
[geomObj_467,geomObj_468] = geompy.ExtractShapes(geomObj_426, geompy.
  ShapeType["VERTEX"], True)
[geomObj_469,geomObj_470] = geompy.ExtractShapes(geomObj_426, geompy.
  ShapeType["VERTEX"], True)
[geomObj_471,geomObj_472] = geompy.ExtractShapes(geomObj_427, geompy.
  ShapeType["VERTEX"], True)
[geomObj_473,geomObj_474] = geompy.ExtractShapes(geomObj_427, geompy.
  ShapeType["VERTEX"], True)
[geomObj_475,geomObj_476] = geompy.ExtractShapes(geomObj_428, geompy.
  ShapeType["VERTEX"], True)
[geomObj_477,geomObj_478] = geompy.ExtractShapes(geomObj_429, geompy.
  ShapeType["VERTEX"], True)
[geomObj_479,geomObj_480] = geompy.ExtractShapes(geomObj_430, geompy.
  ShapeType["VERTEX"], True)
geomObj_481 = geompy.MakeCommonList([geomObj_407, geomObj_408], True)
[geomObj_482,geomObj_483,geomObj_484,geomObj_485,geomObj_486,geomObj_487,
  geomObj_488,geomObj_489,geomObj_490,geomObj_491,geomObj_492] = geompy.
  ExtractShapes(geomObj_481, geompy.ShapeType["VERTEX"], True)
[geomObj_493,geomObj_494,geomObj_495,geomObj_496,geomObj_497,geomObj_498,
  geomObj_499,geomObj_500,geomObj_501,geomObj_502,geomObj_503,
  geomObj_504,geomObj_505,geomObj_506,geomObj_507,geomObj_508] = geompy.
  ExtractShapes(geomObj_481, geompy.ShapeType["EDGE"], True)
[geomObj_509,geomObj_510] = geompy.ExtractShapes(geomObj_493, geompy.
  ShapeType["VERTEX"], True)
[geomObj_511,geomObj_512] = geompy.ExtractShapes(geomObj_493, geompy.
  ShapeType["VERTEX"], True)
[geomObj_513,geomObj_514] = geompy.ExtractShapes(geomObj_493, geompy.
  ShapeType["VERTEX"], True)
[geomObj_515,geomObj_516] = geompy.ExtractShapes(geomObj_494, geompy.
  ShapeType["VERTEX"], True)

```

EDF R&D	code_saturne version 8.0 tutorial: Turbulence simulation in a mixing tee	code_saturne documentation Page 65/127
---------	---	--

```
[geomObj_517,geomObj_518] = geompy.ExtractShapes(geomObj_494, geompy.
    ShapeType["VERTEX"], True)
[geomObj_519,geomObj_520] = geompy.ExtractShapes(geomObj_494, geompy.
    ShapeType["VERTEX"], True)
[geomObj_521,geomObj_522] = geompy.ExtractShapes(geomObj_495, geompy.
    ShapeType["VERTEX"], True)
[geomObj_523,geomObj_524] = geompy.ExtractShapes(geomObj_495, geompy.
    ShapeType["VERTEX"], True)
[geomObj_525,geomObj_526] = geompy.ExtractShapes(geomObj_495, geompy.
    ShapeType["VERTEX"], True)
[geomObj_527,geomObj_528] = geompy.ExtractShapes(geomObj_496, geompy.
    ShapeType["VERTEX"], True)
[geomObj_529,geomObj_530] = geompy.ExtractShapes(geomObj_496, geompy.
    ShapeType["VERTEX"], True)
[geomObj_531,geomObj_532] = geompy.ExtractShapes(geomObj_496, geompy.
    ShapeType["VERTEX"], True)
[geomObj_533,geomObj_534] = geompy.ExtractShapes(geomObj_497, geompy.
    ShapeType["VERTEX"], True)
[geomObj_535,geomObj_536] = geompy.ExtractShapes(geomObj_497, geompy.
    ShapeType["VERTEX"], True)
[geomObj_537,geomObj_538] = geompy.ExtractShapes(geomObj_497, geompy.
    ShapeType["VERTEX"], True)
[geomObj_539,geomObj_540] = geompy.ExtractShapes(geomObj_498, geompy.
    ShapeType["VERTEX"], True)
[geomObj_541,geomObj_542] = geompy.ExtractShapes(geomObj_498, geompy.
    ShapeType["VERTEX"], True)
[geomObj_543,geomObj_544] = geompy.ExtractShapes(geomObj_498, geompy.
    ShapeType["VERTEX"], True)
[geomObj_545,geomObj_546] = geompy.ExtractShapes(geomObj_499, geompy.
    ShapeType["VERTEX"], True)
[geomObj_547,geomObj_548] = geompy.ExtractShapes(geomObj_499, geompy.
    ShapeType["VERTEX"], True)
[geomObj_549,geomObj_550] = geompy.ExtractShapes(geomObj_499, geompy.
    ShapeType["VERTEX"], True)
[geomObj_551,geomObj_552] = geompy.ExtractShapes(geomObj_500, geompy.
    ShapeType["VERTEX"], True)
[geomObj_553,geomObj_554] = geompy.ExtractShapes(geomObj_500, geompy.
    ShapeType["VERTEX"], True)
[geomObj_555,geomObj_556] = geompy.ExtractShapes(geomObj_500, geompy.
    ShapeType["VERTEX"], True)
[geomObj_557,geomObj_558] = geompy.ExtractShapes(geomObj_501, geompy.
    ShapeType["VERTEX"], True)
[geomObj_559,geomObj_560] = geompy.ExtractShapes(geomObj_501, geompy.
    ShapeType["VERTEX"], True)
[geomObj_561,geomObj_562] = geompy.ExtractShapes(geomObj_502, geompy.
    ShapeType["VERTEX"], True)
[geomObj_563,geomObj_564] = geompy.ExtractShapes(geomObj_502, geompy.
    ShapeType["VERTEX"], True)
[geomObj_565,geomObj_566] = geompy.ExtractShapes(geomObj_503, geompy.
    ShapeType["VERTEX"], True)
[geomObj_567,geomObj_568] = geompy.ExtractShapes(geomObj_503, geompy.
    ShapeType["VERTEX"], True)
[geomObj_569,geomObj_570] = geompy.ExtractShapes(geomObj_504, geompy.
    ShapeType["VERTEX"], True)
```

```

[geomObj_571,geomObj_572] = geompy.ExtractShapes(geomObj_505, geompy.
    ShapeType["VERTEX"], True)
[geomObj_573,geomObj_574] = geompy.ExtractShapes(geomObj_506, geompy.
    ShapeType["VERTEX"], True)
[geomObj_575,geomObj_576] = geompy.ExtractShapes(geomObj_507, geompy.
    ShapeType["VERTEX"], True)
[geomObj_577,geomObj_578] = geompy.ExtractShapes(geomObj_508, geompy.
    ShapeType["VERTEX"], True)
geomObj_579 = geompy.MakePlaneThreePnt(geomObj_343, geomObj_344,
    geomObj_354, 10000)
geomObj_580 = geompy.MakeProjection(geomObj_412, geomObj_579)
geomObj_581 = geompy.MakeProjection(geomObj_413, geomObj_579)
geomObj_582 = geompy.MakeProjection(geomObj_414, geomObj_579)
geomObj_583 = geompy.MakeProjection(geomObj_415, geomObj_579)
geomObj_584 = geompy.MakeProjection(geomObj_416, geomObj_579)
geomObj_585 = geompy.MakeProjection(geomObj_417, geomObj_579)
geomObj_586 = geompy.MakeProjection(geomObj_418, geomObj_579)
geomObj_587 = geompy.MakeProjection(geomObj_419, geomObj_579)
geomObj_588 = geompy.MakePlaneThreePnt(geomObj_388, geomObj_389,
    geomObj_395, 10000)
geomObj_589 = geompy.MakeProjection(geomObj_482, geomObj_588)
geomObj_590 = geompy.MakeProjection(geomObj_483, geomObj_588)
geomObj_591 = geompy.MakeProjection(geomObj_484, geomObj_588)
geomObj_592 = geompy.MakeProjection(geomObj_485, geomObj_588)
geomObj_593 = geompy.MakeProjection(geomObj_486, geomObj_588)
geomObj_594 = geompy.MakeProjection(geomObj_487, geomObj_588)
geomObj_595 = geompy.MakeProjection(geomObj_488, geomObj_588)
geomObj_596 = geompy.MakeProjection(geomObj_489, geomObj_588)
geomObj_597 = geompy.MakeProjection(geomObj_490, geomObj_588)
geomObj_598 = geompy.MakeProjection(geomObj_491, geomObj_588)
geomObj_599 = geompy.MakeProjection(geomObj_492, geomObj_588)
geomObj_600 = geompy.MakeTranslation(geomObj_485, 0, 0, -0.05)
geomObj_601 = geompy.MakeTranslation(geomObj_483, 0, 0, -0.05)
geomObj_602 = geompy.MakeTranslation(geomObj_489, 0, 0, -0.05)
geomObj_603 = geompy.MakeTranslation(geomObj_487, 0, 0, -0.05)
geomObj_604 = geompy.MakeArcCenter(geomObj_334, geomObj_486, geomObj_415,
    False)
geomObj_605 = geompy.MakeArcCenter(geomObj_334, geomObj_482, geomObj_412,
    False)
geomObj_606 = geompy.MakePlaneThreePnt(geomObj_491, geomObj_419,
    geomObj_417, 10000)
geomObj_607 = geompy.MakeSection(geomObj_606, geomObj_408, True)
geomObj_608 = geompy.MakePartition([geomObj_607], [geomObj_411,
    geomObj_481], [], [], geompy.ShapeType["EDGE"], 0, [], 0)
[geomObj_609,geomObj_610,geomObj_611,geomObj_612] = geompy.ExtractShapes(
    geomObj_608, geompy.ShapeType["EDGE"], True)
[geomObj_613,geomObj_614] = geompy.ExtractShapes(geomObj_609, geompy.
    ShapeType["VERTEX"], True)
[geomObj_615,geomObj_616] = geompy.ExtractShapes(geomObj_610, geompy.
    ShapeType["VERTEX"], True)
[geomObj_617,geomObj_618] = geompy.ExtractShapes(geomObj_611, geompy.
    ShapeType["VERTEX"], True)
geomObj_619 = geompy.MakePlaneThreePnt(geomObj_490, geomObj_418,
    geomObj_416, 10000)
geomObj_620 = geompy.MakeSection(geomObj_619, geomObj_408, True)

```

EDF R&D	code_saturne version 8.0 tutorial: Turbulence simulation in a mixing tee	code_saturne documentation Page 67/127
---------	---	--

```

geomObj_621 = geompy.MakePartition([geomObj_620], [geomObj_411,
    geomObj_481], [], [], geompy.ShapeType["EDGE"], 0, [], 0)
[geomObj_622, geomObj_623, geomObj_624, geomObj_625] = geompy.ExtractShapes(
    geomObj_621, geompy.ShapeType["EDGE"], True)
[geomObj_626, geomObj_627] = geompy.ExtractShapes(geomObj_622, geompy.
    ShapeType["VERTEX"], True)
[geomObj_628, geomObj_629] = geompy.ExtractShapes(geomObj_623, geompy.
    ShapeType["VERTEX"], True)
[geomObj_630, geomObj_631] = geompy.ExtractShapes(geomObj_624, geompy.
    ShapeType["VERTEX"], True)
geomObj_632 = geompy.MakeLineTwoPnt(geomObj_414, geomObj_600)
geomObj_633 = geompy.MakeLineTwoPnt(geomObj_413, geomObj_601)
geomObj_634 = geompy.MakeLineTwoPnt(geomObj_417, geomObj_602)
geomObj_635 = geompy.MakeLineTwoPnt(geomObj_416, geomObj_603)
geomObj_636 = geompy.MakeLineTwoPnt(geomObj_414, geomObj_413)
geomObj_637 = geompy.MakeLineTwoPnt(geomObj_414, geomObj_415)
geomObj_638 = geompy.MakeLineTwoPnt(geomObj_417, geomObj_419)
geomObj_639 = geompy.MakeLineTwoPnt(geomObj_413, geomObj_412)
geomObj_640 = geompy.MakeLineTwoPnt(geomObj_416, geomObj_418)
geomObj_641 = geompy.MakeLineTwoPnt(geomObj_417, geomObj_416)
geomObj_642 = geompy.MakeLineTwoPnt(geomObj_414, geomObj_417)
geomObj_643 = geompy.MakeLineTwoPnt(geomObj_413, geomObj_416)
geomObj_644 = geompy.MakeLineTwoPnt(geomObj_600, geomObj_601)
geomObj_645 = geompy.MakeLineTwoPnt(geomObj_600, geomObj_486)
geomObj_646 = geompy.MakeLineTwoPnt(geomObj_602, geomObj_491)
geomObj_647 = geompy.MakeLineTwoPnt(geomObj_601, geomObj_482)
geomObj_648 = geompy.MakeLineTwoPnt(geomObj_603, geomObj_490)
geomObj_649 = geompy.MakeLineTwoPnt(geomObj_602, geomObj_603)
geomObj_650 = geompy.MakeLineTwoPnt(geomObj_600, geomObj_602)
geomObj_651 = geompy.MakeLineTwoPnt(geomObj_601, geomObj_603)
geomObj_652 = geompy.MakeFaceWires([geomObj_642, geomObj_632, geomObj_650
    , geomObj_634], 0)
geomObj_653 = geompy.MakeFaceWires([geomObj_643, geomObj_633, geomObj_651
    , geomObj_635], 0)
geomObj_654 = geompy.MakeFaceWires([geomObj_638, geomObj_634, geomObj_646
    , geomObj_611], 0)
geomObj_655 = geompy.MakeFaceWires([geomObj_641, geomObj_634, geomObj_649
    , geomObj_635], 0)
geomObj_656 = geompy.MakeFaceWires([geomObj_640, geomObj_635, geomObj_648
    , geomObj_624], 0)
geomObj_657 = geompy.MakeFaceWires([geomObj_644, geomObj_650, geomObj_649
    , geomObj_651], 0)
geomObj_658 = geompy.MakeFaceWires([geomObj_645, geomObj_650, geomObj_646
    , geomObj_503], 0)
geomObj_659 = geompy.MakeVertex(0, 0, 0)
geomObj_660 = geompy.MakeVectorDXDYDZ(1, 0, 0)
geomObj_661 = geompy.MakeVectorDXDYDZ(0, 1, 0)
geomObj_662 = geompy.MakeVectorDXDYDZ(0, 0, 1)
geomObj_663 = geompy.MakeVertex(0, 0, 0)
geomObj_664 = geompy.MakeVectorDXDYDZ(1, 0, 0)
geomObj_665 = geompy.MakeVectorDXDYDZ(0, 1, 0)
geomObj_666 = geompy.MakeVectorDXDYDZ(0, 0, 1)
geomObj_667 = geompy.MakeVertex(0, 0, 0)
geomObj_668 = geompy.MakeVectorDXDYDZ(1, 0, 0)
geomObj_669 = geompy.MakeVectorDXDYDZ(0, 1, 0)

```

EDF R&D	code_saturne version 8.0 tutorial: Turbulence simulation in a mixing tee	code_saturne documentation Page 68/127
---------	---	--

```

geomObj_670 = geompy.MakeVectorDXDYDZ(0, 0, 1)
geomObj_671 = geompy.MakeVertex(0, 0, 0)
geomObj_672 = geompy.MakeVertex(0, 1.07, 0)
geomObj_673 = geompy.MakeVertex(0, 2.14, 0)
geomObj_674 = geompy.MakeLineTwoPnt(geomObj_672, geomObj_673)
geomObj_675 = geompy.MakeRotation(geomObj_674, geomObj_668, 45*math.pi
/180.0)
geomObj_676 = geompy.MakeRotation(geomObj_672, geomObj_668, 45*math.pi
/180.0)
geomObj_677 = geompy.MakeRotation(geomObj_673, geomObj_668, 45*math.pi
/180.0)
geomObj_678 = geompy.MakeVertex(0, -1.07, 0)
geomObj_679 = geompy.MakeVertex(0, -2.14, 0)
geomObj_680 = geompy.MakeLineTwoPnt(geomObj_678, geomObj_679)
geomObj_681 = geompy.MakeRotation(geomObj_680, geomObj_668, -45*math.pi
/180.0)
geomObj_682 = geompy.MakeRotation(geomObj_678, geomObj_668, -45*math.pi
/180.0)
geomObj_683 = geompy.MakeRotation(geomObj_679, geomObj_668, -45*math.pi
/180.0)
geomObj_684 = geompy.MakeLineTwoPnt(geomObj_676, geomObj_682)
geomObj_685 = geompy.MakeLineTwoPnt(geomObj_672, geomObj_676)
geomObj_686 = geompy.MakeLineTwoPnt(geomObj_678, geomObj_682)
geomObj_687 = geompy.MakeVertex(0, 0, 2.14)
geomObj_688 = geompy.MakeArc(geomObj_673, geomObj_687, geomObj_679)
geomObj_689 = geompy.MakeLineTwoPnt(geomObj_673, geomObj_679)
geomObj_690 = geompy.MakeFaceWires([geomObj_688, geomObj_689], 1)
geomObj_691 = geompy.MakePartition([geomObj_690], [geomObj_675,
geomObj_681, geomObj_684, geomObj_685, geomObj_686], [], [], geompy.
ShapeType["FACE"], 0, [], 0)
geomObj_692 = geompy.MakeVertex(0, 0, 0)
geomObj_693 = geompy.MakeVectorDXDYDZ(1, 0, 0)
geomObj_694 = geompy.MakeVectorDXDYDZ(0, 1, 0)
geomObj_695 = geompy.MakeVectorDXDYDZ(0, 0, 1)
geomObj_696 = geompy.MakeVertex(0, 0, 0)
geomObj_697 = geompy.MakeVertex(0, 0.05, 0)
geomObj_698 = geompy.MakeVertex(0, 0.1, 0)
geomObj_699 = geompy.MakeLineTwoPnt(geomObj_697, geomObj_698)
geomObj_700 = geompy.MakeRotation(geomObj_699, geomObj_693, 45*math.pi
/180.0)
geomObj_701 = geompy.MakeRotation(geomObj_697, geomObj_693, 45*math.pi
/180.0)
geomObj_702 = geompy.MakeRotation(geomObj_698, geomObj_693, 45*math.pi
/180.0)
geomObj_703 = geompy.MakeVertex(0, -0.05, 0)
geomObj_704 = geompy.MakeVertex(0, -0.1, 0)
geomObj_705 = geompy.MakeLineTwoPnt(geomObj_703, geomObj_704)
geomObj_706 = geompy.MakeRotation(geomObj_705, geomObj_693, -45*math.pi
/180.0)
geomObj_707 = geompy.MakeRotation(geomObj_703, geomObj_693, -45*math.pi
/180.0)
geomObj_708 = geompy.MakeRotation(geomObj_704, geomObj_693, -45*math.pi
/180.0)
geomObj_709 = geompy.MakeLineTwoPnt(geomObj_701, geomObj_707)
geomObj_710 = geompy.MakeLineTwoPnt(geomObj_697, geomObj_701)

```

EDF R&D	code_saturne version 8.0 tutorial: Turbulence simulation in a mixing tee	code_saturne documentation Page 69/127
---------	---	--

```

geomObj_711 = geompy.MakeLineTwoPnt(geomObj_703, geomObj_707)
geomObj_712 = geompy.MakeVertex(0, 0, 0.1)
geomObj_713 = geompy.MakeArc(geomObj_698, geomObj_712, geomObj_704)
geomObj_714 = geompy.MakeLineTwoPnt(geomObj_698, geomObj_704)
geomObj_715 = geompy.MakeFaceWires([geomObj_713, geomObj_714], 1)
geomObj_716 = geompy.MakePartition([geomObj_715], [geomObj_700,
    geomObj_706, geomObj_709, geomObj_710, geomObj_711], [], [], geompy.
    ShapeType["FACE"], 0, [], 0)
geomObj_717 = geompy.MakeRotation(geomObj_697, geomObj_694, 90*math.pi
    /180.0)
geomObj_718 = geompy.MakeRotation(geomObj_698, geomObj_694, 90*math.pi
    /180.0)
geomObj_719 = geompy.MakeRotation(geomObj_703, geomObj_694, 90*math.pi
    /180.0)
geomObj_720 = geompy.MakeRotation(geomObj_704, geomObj_694, 90*math.pi
    /180.0)
geomObj_721 = geompy.MakeRotation(geomObj_701, geomObj_694, 90*math.pi
    /180.0)
geomObj_722 = geompy.MakeRotation(geomObj_707, geomObj_694, 90*math.pi
    /180.0)
geomObj_723 = geompy.MakeRotation(geomObj_702, geomObj_694, 90*math.pi
    /180.0)
geomObj_724 = geompy.MakeRotation(geomObj_708, geomObj_694, 90*math.pi
    /180.0)
geomObj_725 = geompy.MakeRotation(geomObj_714, geomObj_694, 90*math.pi
    /180.0)
geomObj_726 = geompy.MakeRotation(geomObj_699, geomObj_694, 90*math.pi
    /180.0)
geomObj_727 = geompy.MakeRotation(geomObj_700, geomObj_694, 90*math.pi
    /180.0)
geomObj_728 = geompy.MakeRotation(geomObj_705, geomObj_694, 90*math.pi
    /180.0)
geomObj_729 = geompy.MakeRotation(geomObj_706, geomObj_694, 90*math.pi
    /180.0)
geomObj_730 = geompy.MakeRotation(geomObj_709, geomObj_694, 90*math.pi
    /180.0)
geomObj_731 = geompy.MakeRotation(geomObj_710, geomObj_694, 90*math.pi
    /180.0)
geomObj_732 = geompy.MakeRotation(geomObj_711, geomObj_694, 90*math.pi
    /180.0)
geomObj_733 = geompy.MakeRotation(geomObj_713, geomObj_694, 90*math.pi
    /180.0)
geomObj_734 = geompy.MakeRotation(geomObj_716, geomObj_694, 90*math.pi
    /180.0)
geomObj_735 = geompy.MakePrismVecH(geomObj_691, geomObj_664, 0.28)
geomObj_736 = geompy.MakePrismVecH(geomObj_734, geomObj_666, 0.14)
geomObj_737 = geompy.MakePrismVecH(geomObj_688, geomObj_664, 0.28)
geomObj_738 = geompy.MakePlane(geomObj_663, geomObj_664, 8.56)
geomObj_739 = geompy.MakeRotation(geomObj_738, geomObj_665, 45*math.pi
    /180.0)
geomObj_740 = geompy.MakeCommonList([geomObj_735, geomObj_739], True)
[geomObj_741, geomObj_742, geomObj_743, geomObj_744, geomObj_745, geomObj_746,
    geomObj_747, geomObj_748] = geompy.ExtractShapes(geomObj_740, geompy.
    ShapeType["VERTEX"], True)

```

```

[geomObj_749 , geomObj_750 , geomObj_751 , geomObj_752 , geomObj_753 , geomObj_754 ,
 geomObj_755 , geomObj_756 , geomObj_757 , geomObj_758 ] = geompy .
  ExtractShapes (geomObj_740 , geompy .ShapeType [ "EDGE" ] , True)
[geomObj_759 , geomObj_760 ] = geompy . ExtractShapes (geomObj_749 , geompy .
  ShapeType [ "VERTEX" ] , True)
[geomObj_761 , geomObj_762 ] = geompy . ExtractShapes (geomObj_750 , geompy .
  ShapeType [ "VERTEX" ] , True)
[geomObj_763 , geomObj_764 ] = geompy . ExtractShapes (geomObj_751 , geompy .
  ShapeType [ "VERTEX" ] , True)
[geomObj_765 , geomObj_766 ] = geompy . ExtractShapes (geomObj_752 , geompy .
  ShapeType [ "VERTEX" ] , True)
[geomObj_767 , geomObj_768 ] = geompy . ExtractShapes (geomObj_753 , geompy .
  ShapeType [ "VERTEX" ] , True)
[geomObj_769 , geomObj_770 ] = geompy . ExtractShapes (geomObj_754 , geompy .
  ShapeType [ "VERTEX" ] , True)
geomObj_771 = geompy . MakeCommonList ([ geomObj_736 , geomObj_737 ] , True)
geomObj_772 = geompy . MakePlaneThreePnt (geomObj_672 , geomObj_673 ,
  geomObj_683 , 10000)
geomObj_773 = geompy . MakeProjection (geomObj_741 , geomObj_772)
geomObj_774 = geompy . MakeProjection (geomObj_742 , geomObj_772)
geomObj_775 = geompy . MakeProjection (geomObj_743 , geomObj_772)
geomObj_776 = geompy . MakeProjection (geomObj_744 , geomObj_772)
geomObj_777 = geompy . MakeProjection (geomObj_745 , geomObj_772)
geomObj_778 = geompy . MakeProjection (geomObj_746 , geomObj_772)
geomObj_779 = geompy . MakeProjection (geomObj_747 , geomObj_772)
geomObj_780 = geompy . MakeProjection (geomObj_748 , geomObj_772)
geomObj_781 = geompy . MakePlaneThreePnt (geomObj_717 , geomObj_718 ,
  geomObj_724 , 10000)
geomObj_782 = geompy . MakeVertex (0 , 0 , 0)
geomObj_783 = geompy . MakeVectorDXDYDZ (1 , 0 , 0)
geomObj_784 = geompy . MakeVectorDXDYDZ (0 , 1 , 0)
geomObj_785 = geompy . MakeVectorDXDYDZ (0 , 0 , 1)
geomObj_786 = geompy . MakeVertex (0 , 0 , 0)
geomObj_787 = geompy . MakeVectorDXDYDZ (1 , 0 , 0)
geomObj_788 = geompy . MakeVectorDXDYDZ (0 , 1 , 0)
geomObj_789 = geompy . MakeVectorDXDYDZ (0 , 0 , 1)
geomObj_790 = geompy . MakeVertex (0 , 0 , 0)
geomObj_791 = geompy . MakeVectorDXDYDZ (1 , 0 , 0)
geomObj_792 = geompy . MakeVectorDXDYDZ (0 , 1 , 0)
geomObj_793 = geompy . MakeVectorDXDYDZ (0 , 0 , 1)
geomObj_794 = geompy . MakeVertex (0 , 0 , 0)
geomObj_795 = geompy . MakeVertex (0 , 1.07 , 0)
geomObj_796 = geompy . MakeVertex (0 , 2.14 , 0)
geomObj_797 = geompy . MakeLineTwoPnt (geomObj_795 , geomObj_796)
geomObj_798 = geompy . MakeRotation (geomObj_797 , geomObj_791 , 45 * math . pi
  / 180.0)
geomObj_799 = geompy . MakeRotation (geomObj_795 , geomObj_791 , 45 * math . pi
  / 180.0)
geomObj_800 = geompy . MakeRotation (geomObj_796 , geomObj_791 , 45 * math . pi
  / 180.0)
geomObj_801 = geompy . MakeVertex (0 , -1.07 , 0)
geomObj_802 = geompy . MakeVertex (0 , -2.14 , 0)
geomObj_803 = geompy . MakeLineTwoPnt (geomObj_801 , geomObj_802)
geomObj_804 = geompy . MakeRotation (geomObj_803 , geomObj_791 , -45 * math . pi
  / 180.0)

```

EDF R&D	code_saturne version 8.0 tutorial: Turbulence simulation in a mixing tee	code_saturne documentation Page 71/127
---------	---	--

```

geomObj_805 = geompy.MakeRotation(geomObj_801, geomObj_791, -45*math.pi
/180.0)
geomObj_806 = geompy.MakeRotation(geomObj_802, geomObj_791, -45*math.pi
/180.0)
geomObj_807 = geompy.MakeLineTwoPnt(geomObj_799, geomObj_805)
geomObj_808 = geompy.MakeLineTwoPnt(geomObj_795, geomObj_799)
geomObj_809 = geompy.MakeLineTwoPnt(geomObj_801, geomObj_805)
geomObj_810 = geompy.MakeVertex(0, 0, 2.14)
geomObj_811 = geompy.MakeArc(geomObj_796, geomObj_810, geomObj_802)
geomObj_812 = geompy.MakeLineTwoPnt(geomObj_796, geomObj_802)
geomObj_813 = geompy.MakeFaceWires([geomObj_811, geomObj_812], 1)
geomObj_814 = geompy.MakePartition([geomObj_813], [geomObj_798,
geomObj_804, geomObj_807, geomObj_808, geomObj_809], [], [], geompy.
ShapeType["FACE"], 0, [], 0)
geomObj_815 = geompy.MakeVertex(0, 0, 0)
geomObj_816 = geompy.MakeVectorDXDYDZ(1, 0, 0)
geomObj_817 = geompy.MakeVectorDXDYDZ(0, 1, 0)
geomObj_818 = geompy.MakeVectorDXDYDZ(0, 0, 1)
geomObj_819 = geompy.MakeVertex(0, 0, 0)
geomObj_820 = geompy.MakeVertex(0, 0.05, 0)
geomObj_821 = geompy.MakeVertex(0, 0.1, 0)
geomObj_822 = geompy.MakeLineTwoPnt(geomObj_820, geomObj_821)
geomObj_823 = geompy.MakeRotation(geomObj_822, geomObj_816, 45*math.pi
/180.0)
geomObj_824 = geompy.MakeRotation(geomObj_820, geomObj_816, 45*math.pi
/180.0)
geomObj_825 = geompy.MakeRotation(geomObj_821, geomObj_816, 45*math.pi
/180.0)
geomObj_826 = geompy.MakeVertex(0, -0.05, 0)
geomObj_827 = geompy.MakeVertex(0, -0.1, 0)
geomObj_828 = geompy.MakeLineTwoPnt(geomObj_826, geomObj_827)
geomObj_829 = geompy.MakeRotation(geomObj_828, geomObj_816, -45*math.pi
/180.0)
geomObj_830 = geompy.MakeRotation(geomObj_826, geomObj_816, -45*math.pi
/180.0)
geomObj_831 = geompy.MakeRotation(geomObj_827, geomObj_816, -45*math.pi
/180.0)
geomObj_832 = geompy.MakeLineTwoPnt(geomObj_824, geomObj_830)
geomObj_833 = geompy.MakeLineTwoPnt(geomObj_820, geomObj_824)
geomObj_834 = geompy.MakeLineTwoPnt(geomObj_826, geomObj_830)
geomObj_835 = geompy.MakeVertex(0, 0, 0.1)
geomObj_836 = geompy.MakeArc(geomObj_821, geomObj_835, geomObj_827)
geomObj_837 = geompy.MakeLineTwoPnt(geomObj_821, geomObj_827)
geomObj_838 = geompy.MakeFaceWires([geomObj_836, geomObj_837], 1)
geomObj_839 = geompy.MakePartition([geomObj_838], [geomObj_823,
geomObj_829, geomObj_832, geomObj_833, geomObj_834], [], [], geompy.
ShapeType["FACE"], 0, [], 0)
geomObj_840 = geompy.MakeRotation(geomObj_820, geomObj_817, 90*math.pi
/180.0)
geomObj_841 = geompy.MakeRotation(geomObj_821, geomObj_817, 90*math.pi
/180.0)
geomObj_842 = geompy.MakeRotation(geomObj_826, geomObj_817, 90*math.pi
/180.0)
geomObj_843 = geompy.MakeRotation(geomObj_827, geomObj_817, 90*math.pi
/180.0)

```



```

geomObj_844 = geompy.MakeRotation(geomObj_824, geomObj_817, 90*math.pi
    /180.0)
geomObj_845 = geompy.MakeRotation(geomObj_830, geomObj_817, 90*math.pi
    /180.0)
geomObj_846 = geompy.MakeRotation(geomObj_825, geomObj_817, 90*math.pi
    /180.0)
geomObj_847 = geompy.MakeRotation(geomObj_831, geomObj_817, 90*math.pi
    /180.0)
geomObj_848 = geompy.MakeRotation(geomObj_837, geomObj_817, 90*math.pi
    /180.0)
geomObj_849 = geompy.MakeRotation(geomObj_822, geomObj_817, 90*math.pi
    /180.0)
geomObj_850 = geompy.MakeRotation(geomObj_823, geomObj_817, 90*math.pi
    /180.0)
geomObj_851 = geompy.MakeRotation(geomObj_828, geomObj_817, 90*math.pi
    /180.0)
geomObj_852 = geompy.MakeRotation(geomObj_829, geomObj_817, 90*math.pi
    /180.0)
geomObj_853 = geompy.MakeRotation(geomObj_832, geomObj_817, 90*math.pi
    /180.0)
geomObj_854 = geompy.MakeRotation(geomObj_833, geomObj_817, 90*math.pi
    /180.0)
geomObj_855 = geompy.MakeRotation(geomObj_834, geomObj_817, 90*math.pi
    /180.0)
geomObj_856 = geompy.MakeRotation(geomObj_836, geomObj_817, 90*math.pi
    /180.0)
geomObj_857 = geompy.MakeRotation(geomObj_839, geomObj_817, 90*math.pi
    /180.0)
geomObj_858 = geompy.MakePrismVecH(geomObj_814, geomObj_787, 0.28)
geomObj_859 = geompy.MakePrismVecH(geomObj_857, geomObj_789, 0.14)
geomObj_860 = geompy.MakePrismVecH(geomObj_811, geomObj_787, 0.28)
geomObj_861 = geompy.MakePlane(geomObj_786, geomObj_787, 8.56)
geomObj_862 = geompy.MakeRotation(geomObj_861, geomObj_788, 45*math.pi
    /180.0)
geomObj_863 = geompy.MakeCommonList([geomObj_858, geomObj_862], True)
[geomObj_864, geomObj_865, geomObj_866, geomObj_867, geomObj_868, geomObj_869,
    geomObj_870, geomObj_871] = geompy.ExtractShapes(geomObj_863, geompy.
    ShapeType["VERTEX"], True)
[geomObj_872, geomObj_873, geomObj_874, geomObj_875, geomObj_876, geomObj_877,
    geomObj_878, geomObj_879, geomObj_880, geomObj_881] = geompy.
    ExtractShapes(geomObj_863, geompy.ShapeType["EDGE"], True)
[geomObj_882, geomObj_883] = geompy.ExtractShapes(geomObj_872, geompy.
    ShapeType["VERTEX"], True)
[geomObj_884, geomObj_885] = geompy.ExtractShapes(geomObj_873, geompy.
    ShapeType["VERTEX"], True)
[geomObj_886, geomObj_887] = geompy.ExtractShapes(geomObj_874, geompy.
    ShapeType["VERTEX"], True)
[geomObj_888, geomObj_889] = geompy.ExtractShapes(geomObj_875, geompy.
    ShapeType["VERTEX"], True)
[geomObj_890, geomObj_891] = geompy.ExtractShapes(geomObj_876, geompy.
    ShapeType["VERTEX"], True)
[geomObj_892, geomObj_893] = geompy.ExtractShapes(geomObj_877, geompy.
    ShapeType["VERTEX"], True)
geomObj_894 = geompy.MakeCommonList([geomObj_859, geomObj_860], True)

```

```

geomObj_895 = geompy.MakePlaneThreePnt(geomObj_795, geomObj_796,
    geomObj_806, 10000)
geomObj_896 = geompy.MakeProjection(geomObj_864, geomObj_895)
geomObj_897 = geompy.MakeProjection(geomObj_865, geomObj_895)
geomObj_898 = geompy.MakeProjection(geomObj_866, geomObj_895)
geomObj_899 = geompy.MakeProjection(geomObj_867, geomObj_895)
geomObj_900 = geompy.MakeProjection(geomObj_868, geomObj_895)
geomObj_901 = geompy.MakeProjection(geomObj_869, geomObj_895)
geomObj_902 = geompy.MakeProjection(geomObj_870, geomObj_895)
geomObj_903 = geompy.MakeProjection(geomObj_871, geomObj_895)
geomObj_904 = geompy.MakePlaneThreePnt(geomObj_840, geomObj_841,
    geomObj_847, 10000)
geomObj_905 = geompy.MakeVertex(0, 0, 0)
geomObj_906 = geompy.MakeVectorDXDYDZ(1, 0, 0)
geomObj_907 = geompy.MakeVectorDXDYDZ(0, 1, 0)
geomObj_908 = geompy.MakeVectorDXDYDZ(0, 0, 1)
geomObj_909 = geompy.MakeVertex(0, 0, 0)
geomObj_910 = geompy.MakeVectorDXDYDZ(1, 0, 0)
geomObj_911 = geompy.MakeVectorDXDYDZ(0, 1, 0)
geomObj_912 = geompy.MakeVectorDXDYDZ(0, 0, 1)
geomObj_913 = geompy.MakeVertex(0, 0, 0)
geomObj_914 = geompy.MakeVectorDXDYDZ(1, 0, 0)
geomObj_915 = geompy.MakeVectorDXDYDZ(0, 1, 0)
geomObj_916 = geompy.MakeVectorDXDYDZ(0, 0, 1)
geomObj_917 = geompy.MakeVertex(0, 0, 0)
geomObj_918 = geompy.MakeVertex(0, 35, 0)
geomObj_919 = geompy.MakeVertex(0, 70, 0)
geomObj_920 = geompy.MakeLineTwoPnt(geomObj_918, geomObj_919)
geomObj_921 = geompy.MakeRotation(geomObj_920, geomObj_914, 45*math.pi
    /180.0)
geomObj_922 = geompy.MakeRotation(geomObj_918, geomObj_914, 45*math.pi
    /180.0)
geomObj_923 = geompy.MakeRotation(geomObj_919, geomObj_914, 45*math.pi
    /180.0)
geomObj_924 = geompy.MakeVertex(0, -35, 0)
geomObj_925 = geompy.MakeVertex(0, -70, 0)
geomObj_926 = geompy.MakeLineTwoPnt(geomObj_924, geomObj_925)
geomObj_927 = geompy.MakeRotation(geomObj_926, geomObj_914, -45*math.pi
    /180.0)
geomObj_928 = geompy.MakeRotation(geomObj_924, geomObj_914, -45*math.pi
    /180.0)
geomObj_929 = geompy.MakeRotation(geomObj_925, geomObj_914, -45*math.pi
    /180.0)
geomObj_930 = geompy.MakeLineTwoPnt(geomObj_922, geomObj_928)
geomObj_931 = geompy.MakeLineTwoPnt(geomObj_918, geomObj_922)
geomObj_932 = geompy.MakeLineTwoPnt(geomObj_924, geomObj_928)
geomObj_933 = geompy.MakeVertex(0, 0, 70)
geomObj_934 = geompy.MakeArc(geomObj_919, geomObj_933, geomObj_925)
geomObj_935 = geompy.MakeLineTwoPnt(geomObj_919, geomObj_925)
geomObj_936 = geompy.MakeFaceWires([geomObj_934, geomObj_935], 1)
geomObj_937 = geompy.MakePartition([geomObj_936], [geomObj_921,
    geomObj_927, geomObj_930, geomObj_931, geomObj_932], [], [], geompy.
    ShapeType["FACE"], 0, [], 0)
geomObj_938 = geompy.MakeVertex(0, 0, 0)
geomObj_939 = geompy.MakeVectorDXDYDZ(1, 0, 0)

```

EDF R&D	code_saturne version 8.0 tutorial: Turbulence simulation in a mixing tee	code_saturne documentation Page 74/127
---------	---	--

```

geomObj_940 = geompy.MakeVectorDXDYDZ(0, 1, 0)
geomObj_941 = geompy.MakeVectorDXDYDZ(0, 0, 1)
geomObj_942 = geompy.MakeVertex(0, 0, 0)
geomObj_943 = geompy.MakeVertex(0, 25, 0)
geomObj_944 = geompy.MakeVertex(0, 50, 0)
geomObj_945 = geompy.MakeLineTwoPnt(geomObj_943, geomObj_944)
geomObj_946 = geompy.MakeRotation(geomObj_945, geomObj_939, 45*math.pi
/180.0)
geomObj_947 = geompy.MakeRotation(geomObj_943, geomObj_939, 45*math.pi
/180.0)
geomObj_948 = geompy.MakeRotation(geomObj_944, geomObj_939, 45*math.pi
/180.0)
geomObj_949 = geompy.MakeVertex(0, -25, 0)
geomObj_950 = geompy.MakeVertex(0, -50, 0)
geomObj_951 = geompy.MakeLineTwoPnt(geomObj_949, geomObj_950)
geomObj_952 = geompy.MakeRotation(geomObj_951, geomObj_939, -45*math.pi
/180.0)
geomObj_953 = geompy.MakeRotation(geomObj_949, geomObj_939, -45*math.pi
/180.0)
geomObj_954 = geompy.MakeRotation(geomObj_950, geomObj_939, -45*math.pi
/180.0)
geomObj_955 = geompy.MakeLineTwoPnt(geomObj_947, geomObj_953)
geomObj_956 = geompy.MakeLineTwoPnt(geomObj_943, geomObj_947)
geomObj_957 = geompy.MakeLineTwoPnt(geomObj_949, geomObj_953)
geomObj_958 = geompy.MakeVertex(0, 0, 50)
geomObj_959 = geompy.MakeArc(geomObj_944, geomObj_958, geomObj_950)
geomObj_960 = geompy.MakeLineTwoPnt(geomObj_944, geomObj_950)
geomObj_961 = geompy.MakeFaceWires([geomObj_959, geomObj_960], 1)
geomObj_962 = geompy.MakePartition([geomObj_961], [geomObj_946,
geomObj_952, geomObj_955, geomObj_956, geomObj_957], [], [], geompy.
ShapeType["FACE"], 0, [], 0)
geomObj_963 = geompy.MakeRotation(geomObj_943, geomObj_940, 90*math.pi
/180.0)
geomObj_964 = geompy.MakeRotation(geomObj_944, geomObj_940, 90*math.pi
/180.0)
geomObj_965 = geompy.MakeRotation(geomObj_949, geomObj_940, 90*math.pi
/180.0)
geomObj_966 = geompy.MakeRotation(geomObj_950, geomObj_940, 90*math.pi
/180.0)
geomObj_967 = geompy.MakeRotation(geomObj_947, geomObj_940, 90*math.pi
/180.0)
geomObj_968 = geompy.MakeRotation(geomObj_953, geomObj_940, 90*math.pi
/180.0)
geomObj_969 = geompy.MakeRotation(geomObj_948, geomObj_940, 90*math.pi
/180.0)
geomObj_970 = geompy.MakeRotation(geomObj_954, geomObj_940, 90*math.pi
/180.0)
geomObj_971 = geompy.MakeRotation(geomObj_960, geomObj_940, 90*math.pi
/180.0)
geomObj_972 = geompy.MakeRotation(geomObj_945, geomObj_940, 90*math.pi
/180.0)
geomObj_973 = geompy.MakeRotation(geomObj_946, geomObj_940, 90*math.pi
/180.0)
geomObj_974 = geompy.MakeRotation(geomObj_951, geomObj_940, 90*math.pi
/180.0)

```

```

geomObj_975 = geompy.MakeRotation(geomObj_952, geomObj_940, 90*math.pi
    /180.0)
geomObj_976 = geompy.MakeRotation(geomObj_955, geomObj_940, 90*math.pi
    /180.0)
geomObj_977 = geompy.MakeRotation(geomObj_956, geomObj_940, 90*math.pi
    /180.0)
geomObj_978 = geompy.MakeRotation(geomObj_957, geomObj_940, 90*math.pi
    /180.0)
geomObj_979 = geompy.MakeRotation(geomObj_959, geomObj_940, 90*math.pi
    /180.0)
geomObj_980 = geompy.MakeRotation(geomObj_962, geomObj_940, 90*math.pi
    /180.0)
geomObj_981 = geompy.MakePrismVecH(geomObj_937, geomObj_910, 280)
geomObj_982 = geompy.MakePrismVecH(geomObj_980, geomObj_912, 140)
geomObj_983 = geompy.MakePrismVecH(geomObj_934, geomObj_910, 280)
geomObj_984 = geompy.MakePlane(geomObj_909, geomObj_910, 280)
geomObj_985 = geompy.MakeRotation(geomObj_984, geomObj_911, 45*math.pi
    /180.0)
geomObj_986 = geompy.MakeCommonList([geomObj_981, geomObj_985], True)
[geomObj_987, geomObj_988, geomObj_989, geomObj_990, geomObj_991, geomObj_992,
    geomObj_993, geomObj_994] = geompy.ExtractShapes(geomObj_986, geompy.
    ShapeType["VERTEX"], True)
[geomObj_995, geomObj_996, geomObj_997, geomObj_998, geomObj_999, geomObj_1000
    , geomObj_1001, geomObj_1002, geomObj_1003, geomObj_1004, geomObj_1005] =
    geompy.ExtractShapes(geomObj_986, geompy.ShapeType["EDGE"], True)
[geomObj_1006, geomObj_1007] = geompy.ExtractShapes(geomObj_995, geompy.
    ShapeType["VERTEX"], True)
[geomObj_1008, geomObj_1009] = geompy.ExtractShapes(geomObj_995, geompy.
    ShapeType["VERTEX"], True)
[geomObj_1010, geomObj_1011] = geompy.ExtractShapes(geomObj_995, geompy.
    ShapeType["VERTEX"], True)
[geomObj_1012, geomObj_1013] = geompy.ExtractShapes(geomObj_996, geompy.
    ShapeType["VERTEX"], True)
[geomObj_1014, geomObj_1015] = geompy.ExtractShapes(geomObj_996, geompy.
    ShapeType["VERTEX"], True)
[geomObj_1016, geomObj_1017] = geompy.ExtractShapes(geomObj_996, geompy.
    ShapeType["VERTEX"], True)
[geomObj_1018, geomObj_1019] = geompy.ExtractShapes(geomObj_997, geompy.
    ShapeType["VERTEX"], True)
[geomObj_1020, geomObj_1021] = geompy.ExtractShapes(geomObj_997, geompy.
    ShapeType["VERTEX"], True)
[geomObj_1022, geomObj_1023] = geompy.ExtractShapes(geomObj_997, geompy.
    ShapeType["VERTEX"], True)
[geomObj_1024, geomObj_1025] = geompy.ExtractShapes(geomObj_998, geompy.
    ShapeType["VERTEX"], True)
[geomObj_1026, geomObj_1027] = geompy.ExtractShapes(geomObj_998, geompy.
    ShapeType["VERTEX"], True)
[geomObj_1028, geomObj_1029] = geompy.ExtractShapes(geomObj_998, geompy.
    ShapeType["VERTEX"], True)
[geomObj_1030, geomObj_1031] = geompy.ExtractShapes(geomObj_999, geompy.
    ShapeType["VERTEX"], True)
[geomObj_1032, geomObj_1033] = geompy.ExtractShapes(geomObj_999, geompy.
    ShapeType["VERTEX"], True)
[geomObj_1034, geomObj_1035] = geompy.ExtractShapes(geomObj_999, geompy.
    ShapeType["VERTEX"], True)

```

EDF R&D	code_saturne version 8.0 tutorial: Turbulence simulation in a mixing tee	code_saturne documentation Page 76/127
---------	---	--

```

[geomObj_1036,geomObj_1037] = geompy.ExtractShapes(geomObj_1000, geompy.
    ShapeType["VERTEX"], True)
[geomObj_1038,geomObj_1039] = geompy.ExtractShapes(geomObj_1000, geompy.
    ShapeType["VERTEX"], True)
[geomObj_1040,geomObj_1041] = geompy.ExtractShapes(geomObj_1000, geompy.
    ShapeType["VERTEX"], True)
[geomObj_1042,geomObj_1043] = geompy.ExtractShapes(geomObj_1001, geompy.
    ShapeType["VERTEX"], True)
[geomObj_1044,geomObj_1045] = geompy.ExtractShapes(geomObj_1001, geompy.
    ShapeType["VERTEX"], True)
[geomObj_1046,geomObj_1047] = geompy.ExtractShapes(geomObj_1002, geompy.
    ShapeType["VERTEX"], True)
[geomObj_1048,geomObj_1049] = geompy.ExtractShapes(geomObj_1002, geompy.
    ShapeType["VERTEX"], True)
[geomObj_1050,geomObj_1051] = geompy.ExtractShapes(geomObj_1003, geompy.
    ShapeType["VERTEX"], True)
[geomObj_1052,geomObj_1053] = geompy.ExtractShapes(geomObj_1004, geompy.
    ShapeType["VERTEX"], True)
[geomObj_1054,geomObj_1055] = geompy.ExtractShapes(geomObj_1005, geompy.
    ShapeType["VERTEX"], True)
geomObj_1056 = geompy.MakeCommonList([geomObj_982, geomObj_983], True)
[geomObj_1057,geomObj_1058,geomObj_1059,geomObj_1060,geomObj_1061,
    geomObj_1062,geomObj_1063,geomObj_1064] = geompy.ExtractShapes(
    geomObj_1056, geompy.ShapeType["VERTEX"], True)
[geomObj_1065,geomObj_1066,geomObj_1067,geomObj_1068,geomObj_1069,
    geomObj_1070,geomObj_1071,geomObj_1072,geomObj_1073,geomObj_1074,
    geomObj_1075] = geompy.ExtractShapes(geomObj_1056, geompy.ShapeType["
    EDGE"], True)
[geomObj_1076,geomObj_1077] = geompy.ExtractShapes(geomObj_1065, geompy.
    ShapeType["VERTEX"], True)
[geomObj_1078,geomObj_1079] = geompy.ExtractShapes(geomObj_1065, geompy.
    ShapeType["VERTEX"], True)
[geomObj_1080,geomObj_1081] = geompy.ExtractShapes(geomObj_1065, geompy.
    ShapeType["VERTEX"], True)
[geomObj_1082,geomObj_1083] = geompy.ExtractShapes(geomObj_1066, geompy.
    ShapeType["VERTEX"], True)
[geomObj_1084,geomObj_1085] = geompy.ExtractShapes(geomObj_1066, geompy.
    ShapeType["VERTEX"], True)
[geomObj_1086,geomObj_1087] = geompy.ExtractShapes(geomObj_1066, geompy.
    ShapeType["VERTEX"], True)
[geomObj_1088,geomObj_1089] = geompy.ExtractShapes(geomObj_1067, geompy.
    ShapeType["VERTEX"], True)
[geomObj_1090,geomObj_1091] = geompy.ExtractShapes(geomObj_1067, geompy.
    ShapeType["VERTEX"], True)
[geomObj_1092,geomObj_1093] = geompy.ExtractShapes(geomObj_1067, geompy.
    ShapeType["VERTEX"], True)
[geomObj_1094,geomObj_1095] = geompy.ExtractShapes(geomObj_1068, geompy.
    ShapeType["VERTEX"], True)
[geomObj_1096,geomObj_1097] = geompy.ExtractShapes(geomObj_1068, geompy.
    ShapeType["VERTEX"], True)
[geomObj_1098,geomObj_1099] = geompy.ExtractShapes(geomObj_1068, geompy.
    ShapeType["VERTEX"], True)
[geomObj_1100,geomObj_1101] = geompy.ExtractShapes(geomObj_1069, geompy.
    ShapeType["VERTEX"], True)

```



```

[geomObj_1102,geomObj_1103] = geompy.ExtractShapes(geomObj_1069, geompy.
    ShapeType["VERTEX"], True)
[geomObj_1104,geomObj_1105] = geompy.ExtractShapes(geomObj_1069, geompy.
    ShapeType["VERTEX"], True)
[geomObj_1106,geomObj_1107] = geompy.ExtractShapes(geomObj_1070, geompy.
    ShapeType["VERTEX"], True)
[geomObj_1108,geomObj_1109] = geompy.ExtractShapes(geomObj_1070, geompy.
    ShapeType["VERTEX"], True)
[geomObj_1110,geomObj_1111] = geompy.ExtractShapes(geomObj_1070, geompy.
    ShapeType["VERTEX"], True)
[geomObj_1112,geomObj_1113] = geompy.ExtractShapes(geomObj_1071, geompy.
    ShapeType["VERTEX"], True)
[geomObj_1114,geomObj_1115] = geompy.ExtractShapes(geomObj_1071, geompy.
    ShapeType["VERTEX"], True)
[geomObj_1116,geomObj_1117] = geompy.ExtractShapes(geomObj_1072, geompy.
    ShapeType["VERTEX"], True)
[geomObj_1118,geomObj_1119] = geompy.ExtractShapes(geomObj_1072, geompy.
    ShapeType["VERTEX"], True)
[geomObj_1120,geomObj_1121] = geompy.ExtractShapes(geomObj_1073, geompy.
    ShapeType["VERTEX"], True)
[geomObj_1122,geomObj_1123] = geompy.ExtractShapes(geomObj_1074, geompy.
    ShapeType["VERTEX"], True)
[geomObj_1124,geomObj_1125] = geompy.ExtractShapes(geomObj_1075, geompy.
    ShapeType["VERTEX"], True)
geomObj_1126 = geompy.MakePlaneThreePnt(geomObj_918, geomObj_919,
    geomObj_929, 10000)
geomObj_1127 = geompy.MakeProjection(geomObj_987, geomObj_1126)
geomObj_1128 = geompy.MakeProjection(geomObj_988, geomObj_1126)
geomObj_1129 = geompy.MakeProjection(geomObj_989, geomObj_1126)
geomObj_1130 = geompy.MakeProjection(geomObj_990, geomObj_1126)
geomObj_1131 = geompy.MakeProjection(geomObj_991, geomObj_1126)
geomObj_1132 = geompy.MakeProjection(geomObj_992, geomObj_1126)
geomObj_1133 = geompy.MakeProjection(geomObj_993, geomObj_1126)
geomObj_1134 = geompy.MakeProjection(geomObj_994, geomObj_1126)
geomObj_1135 = geompy.MakePlaneThreePnt(geomObj_963, geomObj_964,
    geomObj_970, 10000)
geomObj_1136 = geompy.MakeProjection(geomObj_1057, geomObj_1135)
geomObj_1137 = geompy.MakeProjection(geomObj_1058, geomObj_1135)
geomObj_1138 = geompy.MakeProjection(geomObj_1059, geomObj_1135)
geomObj_1139 = geompy.MakeProjection(geomObj_1060, geomObj_1135)
geomObj_1140 = geompy.MakeProjection(geomObj_1061, geomObj_1135)
geomObj_1141 = geompy.MakeProjection(geomObj_1062, geomObj_1135)
geomObj_1142 = geompy.MakeProjection(geomObj_1063, geomObj_1135)
geomObj_1143 = geompy.MakeProjection(geomObj_1064, geomObj_1135)
geomObj_1144 = geompy.MakeTranslation(geomObj_1059, 0, 0, -25)
geomObj_1145 = geompy.MakeTranslation(geomObj_1058, 0, 0, -25)
geomObj_1146 = geompy.MakeTranslation(geomObj_1062, 0, 0, -25)
geomObj_1147 = geompy.MakeTranslation(geomObj_1061, 0, 0, -25)
geomObj_1148 = geompy.MakeArcCenter(geomObj_909, geomObj_1060,
    geomObj_990, False)
geomObj_1149 = geompy.MakeArcCenter(geomObj_909, geomObj_1057,
    geomObj_987, False)
geomObj_1150 = geompy.MakePlaneThreePnt(geomObj_1064, geomObj_994,
    geomObj_992, 10000)
geomObj_1151 = geompy.MakeSection(geomObj_1150, geomObj_983, True)

```

EDF R&D	code_saturne version 8.0 tutorial: Turbulence simulation in a mixing tee	code_saturne documentation Page 78/127
---------	---	--

```

geomObj_1152 = geompy.MakePartition([geomObj_1151], [geomObj_986,
    geomObj_1056], [], [], geompy.ShapeType["EDGE"], 0, [], 0)
[geomObj_1153, geomObj_1154, geomObj_1155, geomObj_1156] = geompy.
    ExtractShapes(geomObj_1152, geompy.ShapeType["EDGE"], True)
[geomObj_1157, geomObj_1158] = geompy.ExtractShapes(geomObj_1153, geompy.
    ShapeType["VERTEX"], True)
[geomObj_1159, geomObj_1160] = geompy.ExtractShapes(geomObj_1154, geompy.
    ShapeType["VERTEX"], True)
[geomObj_1161, geomObj_1162] = geompy.ExtractShapes(geomObj_1155, geompy.
    ShapeType["VERTEX"], True)
geomObj_1163 = geompy.MakePlaneThreePnt(geomObj_1063, geomObj_993,
    geomObj_991, 10000)
geomObj_1164 = geompy.MakeSection(geomObj_1163, geomObj_983, True)
geomObj_1165 = geompy.MakePartition([geomObj_1164], [geomObj_986,
    geomObj_1056], [], [], geompy.ShapeType["EDGE"], 0, [], 0)
[geomObj_1166, geomObj_1167, geomObj_1168, geomObj_1169] = geompy.
    ExtractShapes(geomObj_1165, geompy.ShapeType["EDGE"], True)
[geomObj_1170, geomObj_1171] = geompy.ExtractShapes(geomObj_1166, geompy.
    ShapeType["VERTEX"], True)
[geomObj_1172, geomObj_1173] = geompy.ExtractShapes(geomObj_1167, geompy.
    ShapeType["VERTEX"], True)
[geomObj_1174, geomObj_1175] = geompy.ExtractShapes(geomObj_1168, geompy.
    ShapeType["VERTEX"], True)
geomObj_1176 = geompy.MakeLineTwoPnt(geomObj_989, geomObj_1144)
geomObj_1177 = geompy.MakeLineTwoPnt(geomObj_988, geomObj_1145)
geomObj_1178 = geompy.MakeLineTwoPnt(geomObj_992, geomObj_1146)
geomObj_1179 = geompy.MakeLineTwoPnt(geomObj_991, geomObj_1147)
geomObj_1180 = geompy.MakeLineTwoPnt(geomObj_989, geomObj_988)
geomObj_1181 = geompy.MakeLineTwoPnt(geomObj_989, geomObj_990)
geomObj_1182 = geompy.MakeLineTwoPnt(geomObj_992, geomObj_994)
geomObj_1183 = geompy.MakeLineTwoPnt(geomObj_988, geomObj_987)
geomObj_1184 = geompy.MakeLineTwoPnt(geomObj_991, geomObj_993)
geomObj_1185 = geompy.MakeLineTwoPnt(geomObj_992, geomObj_991)
geomObj_1186 = geompy.MakeLineTwoPnt(geomObj_989, geomObj_992)
geomObj_1187 = geompy.MakeLineTwoPnt(geomObj_988, geomObj_991)
geomObj_1188 = geompy.MakeLineTwoPnt(geomObj_1144, geomObj_1145)
geomObj_1189 = geompy.MakeLineTwoPnt(geomObj_1144, geomObj_1060)
geomObj_1190 = geompy.MakeLineTwoPnt(geomObj_1146, geomObj_1064)
geomObj_1191 = geompy.MakeLineTwoPnt(geomObj_1145, geomObj_1057)
geomObj_1192 = geompy.MakeLineTwoPnt(geomObj_1147, geomObj_1063)
geomObj_1193 = geompy.MakeLineTwoPnt(geomObj_1146, geomObj_1147)
geomObj_1194 = geompy.MakeLineTwoPnt(geomObj_1144, geomObj_1146)
geomObj_1195 = geompy.MakeLineTwoPnt(geomObj_1145, geomObj_1147)
geomObj_1196 = geompy.MakeFaceWires([geomObj_1186, geomObj_1176,
    geomObj_1194, geomObj_1178], 0)
geomObj_1197 = geompy.MakeFaceWires([geomObj_1187, geomObj_1177,
    geomObj_1195, geomObj_1179], 0)
geomObj_1198 = geompy.MakeFaceWires([geomObj_1182, geomObj_1178,
    geomObj_1190, geomObj_1155], 0)
geomObj_1199 = geompy.MakeFaceWires([geomObj_1185, geomObj_1178,
    geomObj_1193, geomObj_1179], 0)
geomObj_1200 = geompy.MakeFaceWires([geomObj_1184, geomObj_1179,
    geomObj_1192, geomObj_1168], 0)
geomObj_1201 = geompy.MakeFaceWires([geomObj_1188, geomObj_1194,
    geomObj_1193, geomObj_1195], 0)

```

EDF R&D	code_saturne version 8.0 tutorial: Turbulence simulation in a mixing tee	code_saturne documentation Page 79/127
---------	---	--

```

geomObj_1202 = geompy.MakeFaceWires([geomObj_1189, geomObj_1194,
    geomObj_1190, geomObj_1072], 0)
geomObj_1203 = geompy.MakeFaceWires([geomObj_1190, geomObj_1193,
    geomObj_1192, geomObj_1075], 0)
geomObj_1204 = geompy.MakeFaceWires([geomObj_1191, geomObj_1195,
    geomObj_1192, geomObj_1070], 0)
geomObj_1205 = geompy.MakePrismVecH(geomObj_986, geomObj_906, 290)
geomObj_1206 = geompy.MakePartition([geomObj_1201, geomObj_1202,
    geomObj_1203, geomObj_1204], [], [], [], geompy.ShapeType["FACE"], 0,
    [], 0)
geomObj_1207 = geompy.MakePrismVecH(geomObj_1206, geomObj_908, 140)
geomObj_1208 = geompy.MakeFaceWires([geomObj_934, geomObj_935], 1)
geomObj_1209 = geompy.MakePrismVecH(geomObj_1208, geomObj_906, 280)
geomObj_1210 = geompy.MakeVertex(0, -700, -700)
geomObj_1211 = geompy.MakeVertex(700, 700, 700)
geomObj_1212 = geompy.MakeBoxTwoPnt(geomObj_1210, geomObj_1211)
geomObj_1213 = geompy.MakeRotation(geomObj_1212, geomObj_907, 45*math.pi
    /180.0)
geomObj_1214 = geompy.MakeCutList(geomObj_1209, [geomObj_1207,
    geomObj_1213], True)
geomObj_1215 = geompy.MakePartition([geomObj_1214], [geomObj_1196,
    geomObj_1197, geomObj_1198, geomObj_1199, geomObj_1200, geomObj_983],
    [], [], geompy.ShapeType["SOLID"], 0, [], 0)
geomObj_1216 = geompy.MakeCompound([geomObj_1215, geomObj_1205,
    geomObj_1207])
geomObj_1217 = geompy.MakeGlueFaces(geomObj_1216, 1e-07)
geomObj_1218 = geompy.MakeVertex(-1, -120, -1)
geomObj_1219 = geompy.MakeVertex(280, 120, 140)
geomObj_1220 = geompy.MakeBoxTwoPnt(geomObj_1218, geomObj_1219)
geomObj_1221 = geompy.MakeCommonList([geomObj_1220, geomObj_1217], True)
geomObj_1222 = geompy.MakeVertex(0, 0, 0)
geomObj_1223 = geompy.MakeVectorDXDYDZ(1, 0, 0)
geomObj_1224 = geompy.MakeVectorDXDYDZ(0, 1, 0)
geomObj_1225 = geompy.MakeVectorDXDYDZ(0, 0, 1)
geomObj_1226 = geompy.MakeVertex(0, 0, 0)
geomObj_1227 = geompy.MakeVertex(0, 35, 0)
geomObj_1228 = geompy.MakeVertex(0, 70, 0)
geomObj_1229 = geompy.MakeLineTwoPnt(geomObj_1227, geomObj_1228)
geomObj_1230 = geompy.MakeRotation(geomObj_1229, geomObj_1223, 45*math.pi
    /180.0)
geomObj_1231 = geompy.MakeRotation(geomObj_1227, geomObj_1223, 45*math.pi
    /180.0)
geomObj_1232 = geompy.MakeRotation(geomObj_1228, geomObj_1223, 45*math.pi
    /180.0)
geomObj_1233 = geompy.MakeVertex(0, -35, 0)
geomObj_1234 = geompy.MakeVertex(0, -70, 0)
geomObj_1235 = geompy.MakeLineTwoPnt(geomObj_1233, geomObj_1234)
geomObj_1236 = geompy.MakeRotation(geomObj_1235, geomObj_1223, -45*math.
    pi/180.0)
geomObj_1237 = geompy.MakeRotation(geomObj_1233, geomObj_1223, -45*math.
    pi/180.0)
geomObj_1238 = geompy.MakeRotation(geomObj_1234, geomObj_1223, -45*math.
    pi/180.0)
geomObj_1239 = geompy.MakeLineTwoPnt(geomObj_1231, geomObj_1237)
geomObj_1240 = geompy.MakeLineTwoPnt(geomObj_1227, geomObj_1231)

```

EDF R&D	code_saturne version 8.0 tutorial: Turbulence simulation in a mixing tee	code_saturne documentation Page 80/127
---------	---	--

```

geomObj_1241 = geompy.MakeLineTwoPnt(geomObj_1233 , geomObj_1237)
geomObj_1242 = geompy.MakeVertex(0 , 0 , 70)
geomObj_1243 = geompy.MakeArc(geomObj_1228 , geomObj_1242 , geomObj_1234)
geomObj_1244 = geompy.MakeLineTwoPnt(geomObj_1228 , geomObj_1234)
geomObj_1245 = geompy.MakeFaceWires([geomObj_1243 , geomObj_1244] , 1)
geomObj_1246 = geompy.MakePartition([geomObj_1245] , [geomObj_1230 ,
    geomObj_1236 , geomObj_1239 , geomObj_1240 , geomObj_1241] , [], [],
    geompy.ShapeType["FACE"] , 0 , [], 0)
geomObj_1247 = geompy.MakeRotation(geomObj_1227 , geomObj_1224 , 180*math.
    pi/180.0)
geomObj_1248 = geompy.MakeRotation(geomObj_1228 , geomObj_1224 , 180*math.
    pi/180.0)
geomObj_1249 = geompy.MakeRotation(geomObj_1233 , geomObj_1224 , 180*math.
    pi/180.0)
geomObj_1250 = geompy.MakeRotation(geomObj_1234 , geomObj_1224 , 180*math.
    pi/180.0)
geomObj_1251 = geompy.MakeRotation(geomObj_1231 , geomObj_1224 , 180*math.
    pi/180.0)
geomObj_1252 = geompy.MakeRotation(geomObj_1237 , geomObj_1224 , 180*math.
    pi/180.0)
geomObj_1253 = geompy.MakeRotation(geomObj_1232 , geomObj_1224 , 180*math.
    pi/180.0)
geomObj_1254 = geompy.MakeRotation(geomObj_1238 , geomObj_1224 , 180*math.
    pi/180.0)
geomObj_1255 = geompy.MakeRotation(geomObj_1244 , geomObj_1224 , 180*math.
    pi/180.0)
geomObj_1256 = geompy.MakeRotation(geomObj_1229 , geomObj_1224 , 180*math.
    pi/180.0)
geomObj_1257 = geompy.MakeRotation(geomObj_1230 , geomObj_1224 , 180*math.
    pi/180.0)
geomObj_1258 = geompy.MakeRotation(geomObj_1235 , geomObj_1224 , 180*math.
    pi/180.0)
geomObj_1259 = geompy.MakeRotation(geomObj_1236 , geomObj_1224 , 180*math.
    pi/180.0)
geomObj_1260 = geompy.MakeRotation(geomObj_1239 , geomObj_1224 , 180*math.
    pi/180.0)
geomObj_1261 = geompy.MakeRotation(geomObj_1240 , geomObj_1224 , 180*math.
    pi/180.0)
geomObj_1262 = geompy.MakeRotation(geomObj_1241 , geomObj_1224 , 180*math.
    pi/180.0)
geomObj_1263 = geompy.MakeRotation(geomObj_1243 , geomObj_1224 , 180*math.
    pi/180.0)
geomObj_1264 = geompy.MakeRotation(geomObj_1246 , geomObj_1224 , 180*math.
    pi/180.0)
geomObj_1265 = geompy.MakePrismVecH(geomObj_1264 , geomObj_906 , 280)
geomObj_1266 = geompy.MakeCompound([geomObj_1221 , geomObj_1265])
geomObj_1267 = geompy.MakePlane(geomObj_905 , geomObj_906 , 2000)
geomObj_1268 = geompy.MakeMirrorByPlane(geomObj_1266 , geomObj_1267)
geomObj_1269 = geompy.MakeCompound([geomObj_1266 , geomObj_1268])
geomObj_1270 = geompy.MakeGlueFaces(geomObj_1269 , 1e-07)
geomObj_1271 = geompy.MakeVertex(0 , 0 , 0)
geomObj_1272 = geompy.MakeVectorDXDYDZ(1 , 0 , 0)
geomObj_1273 = geompy.MakeVectorDXDYDZ(0 , 1 , 0)
geomObj_1274 = geompy.MakeVectorDXDYDZ(0 , 0 , 1)
geomObj_1275 = geompy.MakeVertex(0 , 0 , 0)

```

EDF R&D	code_saturne version 8.0 tutorial: Turbulence simulation in a mixing tee	code_saturne documentation Page 81/127
---------	---	--

```

geomObj_1276 = geompy.MakeVectorDXDYDZ(1, 0, 0)
geomObj_1277 = geompy.MakeVectorDXDYDZ(0, 1, 0)
geomObj_1278 = geompy.MakeVectorDXDYDZ(0, 0, 1)
geomObj_1279 = geompy.MakeVertex(0, 0, 0)
geomObj_1280 = geompy.MakeVectorDXDYDZ(1, 0, 0)
geomObj_1281 = geompy.MakeVectorDXDYDZ(0, 1, 0)
geomObj_1282 = geompy.MakeVectorDXDYDZ(0, 0, 1)
geomObj_1283 = geompy.MakeVertex(0, 0, 0)
geomObj_1284 = geompy.MakeVertex(0, 35, 0)
geomObj_1285 = geompy.MakeVertex(0, 70, 0)
geomObj_1286 = geompy.MakeLineTwoPnt(geomObj_1284, geomObj_1285)
geomObj_1287 = geompy.MakeRotation(geomObj_1286, geomObj_1280, 45*math.pi
/180.0)
geomObj_1288 = geompy.MakeRotation(geomObj_1284, geomObj_1280, 45*math.pi
/180.0)
geomObj_1289 = geompy.MakeRotation(geomObj_1285, geomObj_1280, 45*math.pi
/180.0)
geomObj_1290 = geompy.MakeVertex(0, -35, 0)
geomObj_1291 = geompy.MakeVertex(0, -70, 0)
geomObj_1292 = geompy.MakeLineTwoPnt(geomObj_1290, geomObj_1291)
geomObj_1293 = geompy.MakeRotation(geomObj_1292, geomObj_1280, -45*math.
pi/180.0)
geomObj_1294 = geompy.MakeRotation(geomObj_1290, geomObj_1280, -45*math.
pi/180.0)
geomObj_1295 = geompy.MakeRotation(geomObj_1291, geomObj_1280, -45*math.
pi/180.0)
geomObj_1296 = geompy.MakeLineTwoPnt(geomObj_1288, geomObj_1294)
geomObj_1297 = geompy.MakeLineTwoPnt(geomObj_1284, geomObj_1288)
geomObj_1298 = geompy.MakeLineTwoPnt(geomObj_1290, geomObj_1294)
geomObj_1299 = geompy.MakeVertex(0, 0, 70)
geomObj_1300 = geompy.MakeArc(geomObj_1285, geomObj_1299, geomObj_1291)
geomObj_1301 = geompy.MakeLineTwoPnt(geomObj_1285, geomObj_1291)
geomObj_1302 = geompy.MakeFaceWires([geomObj_1300, geomObj_1301], 1)
geomObj_1303 = geompy.MakePartition([geomObj_1302], [geomObj_1287,
geomObj_1293, geomObj_1296, geomObj_1297, geomObj_1298], [], [],
geompy.ShapeType["FACE"], 0, [], 0)
geomObj_1304 = geompy.MakeVertex(0, 0, 0)
geomObj_1305 = geompy.MakeVectorDXDYDZ(1, 0, 0)
geomObj_1306 = geompy.MakeVectorDXDYDZ(0, 1, 0)
geomObj_1307 = geompy.MakeVectorDXDYDZ(0, 0, 1)
geomObj_1308 = geompy.MakeVertex(0, 0, 0)
geomObj_1309 = geompy.MakeVertex(0, 25, 0)
geomObj_1310 = geompy.MakeVertex(0, 50, 0)
geomObj_1311 = geompy.MakeLineTwoPnt(geomObj_1309, geomObj_1310)
geomObj_1312 = geompy.MakeRotation(geomObj_1311, geomObj_1305, 45*math.pi
/180.0)
geomObj_1313 = geompy.MakeRotation(geomObj_1309, geomObj_1305, 45*math.pi
/180.0)
geomObj_1314 = geompy.MakeRotation(geomObj_1310, geomObj_1305, 45*math.pi
/180.0)
geomObj_1315 = geompy.MakeVertex(0, -25, 0)
geomObj_1316 = geompy.MakeVertex(0, -50, 0)
geomObj_1317 = geompy.MakeLineTwoPnt(geomObj_1315, geomObj_1316)
geomObj_1318 = geompy.MakeRotation(geomObj_1317, geomObj_1305, -45*math.
pi/180.0)

```

EDF R&D	code_saturne version 8.0 tutorial: Turbulence simulation in a mixing tee	code_saturne documentation Page 82/127
---------	---	--

```

geomObj_1319 = geompy.MakeRotation(geomObj_1315, geomObj_1305, -45*math.
    pi/180.0)
geomObj_1320 = geompy.MakeRotation(geomObj_1316, geomObj_1305, -45*math.
    pi/180.0)
geomObj_1321 = geompy.MakeLineTwoPnt(geomObj_1313, geomObj_1319)
geomObj_1322 = geompy.MakeLineTwoPnt(geomObj_1309, geomObj_1313)
geomObj_1323 = geompy.MakeLineTwoPnt(geomObj_1315, geomObj_1319)
geomObj_1324 = geompy.MakeVertex(0, 0, 50)
geomObj_1325 = geompy.MakeArc(geomObj_1310, geomObj_1324, geomObj_1316)
geomObj_1326 = geompy.MakeLineTwoPnt(geomObj_1310, geomObj_1316)
geomObj_1327 = geompy.MakeFaceWires([geomObj_1325, geomObj_1326], 1)
geomObj_1328 = geompy.MakePartition([geomObj_1327], [geomObj_1312,
    geomObj_1318, geomObj_1321, geomObj_1322, geomObj_1323], [], [],
    geompy.ShapeType["FACE"], 0, [], 0)
geomObj_1329 = geompy.MakeRotation(geomObj_1309, geomObj_1306, 90*math.pi
    /180.0)
geomObj_1330 = geompy.MakeRotation(geomObj_1310, geomObj_1306, 90*math.pi
    /180.0)
geomObj_1331 = geompy.MakeRotation(geomObj_1315, geomObj_1306, 90*math.pi
    /180.0)
geomObj_1332 = geompy.MakeRotation(geomObj_1316, geomObj_1306, 90*math.pi
    /180.0)
geomObj_1333 = geompy.MakeRotation(geomObj_1313, geomObj_1306, 90*math.pi
    /180.0)
geomObj_1334 = geompy.MakeRotation(geomObj_1319, geomObj_1306, 90*math.pi
    /180.0)
geomObj_1335 = geompy.MakeRotation(geomObj_1314, geomObj_1306, 90*math.pi
    /180.0)
geomObj_1336 = geompy.MakeRotation(geomObj_1320, geomObj_1306, 90*math.pi
    /180.0)
geomObj_1337 = geompy.MakeRotation(geomObj_1326, geomObj_1306, 90*math.pi
    /180.0)
geomObj_1338 = geompy.MakeRotation(geomObj_1311, geomObj_1306, 90*math.pi
    /180.0)
geomObj_1339 = geompy.MakeRotation(geomObj_1312, geomObj_1306, 90*math.pi
    /180.0)
geomObj_1340 = geompy.MakeRotation(geomObj_1317, geomObj_1306, 90*math.pi
    /180.0)
geomObj_1341 = geompy.MakeRotation(geomObj_1318, geomObj_1306, 90*math.pi
    /180.0)
geomObj_1342 = geompy.MakeRotation(geomObj_1321, geomObj_1306, 90*math.pi
    /180.0)
geomObj_1343 = geompy.MakeRotation(geomObj_1322, geomObj_1306, 90*math.pi
    /180.0)
geomObj_1344 = geompy.MakeRotation(geomObj_1323, geomObj_1306, 90*math.pi
    /180.0)
geomObj_1345 = geompy.MakeRotation(geomObj_1325, geomObj_1306, 90*math.pi
    /180.0)
geomObj_1346 = geompy.MakeRotation(geomObj_1328, geomObj_1306, 90*math.pi
    /180.0)
geomObj_1347 = geompy.MakePrismVecH(geomObj_1303, geomObj_1276, 140)
geomObj_1348 = geompy.MakePrismVecH(geomObj_1346, geomObj_1278, 140)
geomObj_1349 = geompy.MakePrismVecH(geomObj_1300, geomObj_1276, 140)
geomObj_1350 = geompy.MakePlane(geomObj_1275, geomObj_1276, 280)

```

EDF R&D	code_saturne version 8.0 tutorial: Turbulence simulation in a mixing tee	code_saturne documentation Page 83/127
---------	---	--

```

geomObj_1351 = geompy.MakeRotation(geomObj_1350, geomObj_1277, 45*math.pi
/180.0)
geomObj_1352 = geompy.MakeCommonList([geomObj_1347, geomObj_1351], True)
[geomObj_1353, geomObj_1354, geomObj_1355, geomObj_1356, geomObj_1357,
geomObj_1358, geomObj_1359, geomObj_1360] = geompy.ExtractShapes(
geomObj_1352, geompy.ShapeType["VERTEX"], True)
[geomObj_1361, geomObj_1362, geomObj_1363, geomObj_1364, geomObj_1365,
geomObj_1366, geomObj_1367, geomObj_1368, geomObj_1369, geomObj_1370,
geomObj_1371] = geompy.ExtractShapes(geomObj_1352, geompy.ShapeType["
EDGE"], True)
[geomObj_1372, geomObj_1373] = geompy.ExtractShapes(geomObj_1361, geompy.
ShapeType["VERTEX"], True)
[geomObj_1374, geomObj_1375] = geompy.ExtractShapes(geomObj_1361, geompy.
ShapeType["VERTEX"], True)
[geomObj_1376, geomObj_1377] = geompy.ExtractShapes(geomObj_1361, geompy.
ShapeType["VERTEX"], True)
[geomObj_1378, geomObj_1379] = geompy.ExtractShapes(geomObj_1362, geompy.
ShapeType["VERTEX"], True)
[geomObj_1380, geomObj_1381] = geompy.ExtractShapes(geomObj_1362, geompy.
ShapeType["VERTEX"], True)
[geomObj_1382, geomObj_1383] = geompy.ExtractShapes(geomObj_1362, geompy.
ShapeType["VERTEX"], True)
[geomObj_1384, geomObj_1385] = geompy.ExtractShapes(geomObj_1363, geompy.
ShapeType["VERTEX"], True)
[geomObj_1386, geomObj_1387] = geompy.ExtractShapes(geomObj_1363, geompy.
ShapeType["VERTEX"], True)
[geomObj_1388, geomObj_1389] = geompy.ExtractShapes(geomObj_1363, geompy.
ShapeType["VERTEX"], True)
[geomObj_1390, geomObj_1391] = geompy.ExtractShapes(geomObj_1364, geompy.
ShapeType["VERTEX"], True)
[geomObj_1392, geomObj_1393] = geompy.ExtractShapes(geomObj_1364, geompy.
ShapeType["VERTEX"], True)
[geomObj_1394, geomObj_1395] = geompy.ExtractShapes(geomObj_1364, geompy.
ShapeType["VERTEX"], True)
[geomObj_1396, geomObj_1397] = geompy.ExtractShapes(geomObj_1365, geompy.
ShapeType["VERTEX"], True)
[geomObj_1398, geomObj_1399] = geompy.ExtractShapes(geomObj_1365, geompy.
ShapeType["VERTEX"], True)
[geomObj_1400, geomObj_1401] = geompy.ExtractShapes(geomObj_1365, geompy.
ShapeType["VERTEX"], True)
[geomObj_1402, geomObj_1403] = geompy.ExtractShapes(geomObj_1366, geompy.
ShapeType["VERTEX"], True)
[geomObj_1404, geomObj_1405] = geompy.ExtractShapes(geomObj_1366, geompy.
ShapeType["VERTEX"], True)
[geomObj_1406, geomObj_1407] = geompy.ExtractShapes(geomObj_1366, geompy.
ShapeType["VERTEX"], True)
[geomObj_1408, geomObj_1409] = geompy.ExtractShapes(geomObj_1367, geompy.
ShapeType["VERTEX"], True)
[geomObj_1410, geomObj_1411] = geompy.ExtractShapes(geomObj_1367, geompy.
ShapeType["VERTEX"], True)
[geomObj_1412, geomObj_1413] = geompy.ExtractShapes(geomObj_1368, geompy.
ShapeType["VERTEX"], True)
[geomObj_1414, geomObj_1415] = geompy.ExtractShapes(geomObj_1368, geompy.
ShapeType["VERTEX"], True)

```

EDF R&D	code_saturne version 8.0 tutorial: Turbulence simulation in a mixing tee	code_saturne documentation Page 84/127
---------	---	--

```

[geomObj_1416 ,geomObj_1417] = geompj.ExtractShapes(geomObj_1369 , geompj.
  ShapeType["VERTEX"], True)
[geomObj_1418 ,geomObj_1419] = geompj.ExtractShapes(geomObj_1370 , geompj.
  ShapeType["VERTEX"], True)
[geomObj_1420 ,geomObj_1421] = geompj.ExtractShapes(geomObj_1371 , geompj.
  ShapeType["VERTEX"], True)
geomObj_1422 = geompj.MakeCommonList([geomObj_1348 , geomObj_1349], True)
[geomObj_1423 ,geomObj_1424 ,geomObj_1425 ,geomObj_1426 ,geomObj_1427 ,
  geomObj_1428 ,geomObj_1429 ,geomObj_1430] = geompj.ExtractShapes(
  geomObj_1422 , geompj.ShapeType["VERTEX"], True)
[geomObj_1431 ,geomObj_1432 ,geomObj_1433 ,geomObj_1434 ,geomObj_1435 ,
  geomObj_1436 ,geomObj_1437 ,geomObj_1438 ,geomObj_1439 ,geomObj_1440 ,
  geomObj_1441] = geompj.ExtractShapes(geomObj_1422 , geompj.ShapeType["
  EDGE"], True)
[geomObj_1442 ,geomObj_1443] = geompj.ExtractShapes(geomObj_1431 , geompj.
  ShapeType["VERTEX"], True)
[geomObj_1444 ,geomObj_1445] = geompj.ExtractShapes(geomObj_1431 , geompj.
  ShapeType["VERTEX"], True)
[geomObj_1446 ,geomObj_1447] = geompj.ExtractShapes(geomObj_1431 , geompj.
  ShapeType["VERTEX"], True)
[geomObj_1448 ,geomObj_1449] = geompj.ExtractShapes(geomObj_1432 , geompj.
  ShapeType["VERTEX"], True)
[geomObj_1450 ,geomObj_1451] = geompj.ExtractShapes(geomObj_1432 , geompj.
  ShapeType["VERTEX"], True)
[geomObj_1452 ,geomObj_1453] = geompj.ExtractShapes(geomObj_1432 , geompj.
  ShapeType["VERTEX"], True)
[geomObj_1454 ,geomObj_1455] = geompj.ExtractShapes(geomObj_1433 , geompj.
  ShapeType["VERTEX"], True)
[geomObj_1456 ,geomObj_1457] = geompj.ExtractShapes(geomObj_1433 , geompj.
  ShapeType["VERTEX"], True)
[geomObj_1458 ,geomObj_1459] = geompj.ExtractShapes(geomObj_1433 , geompj.
  ShapeType["VERTEX"], True)
[geomObj_1460 ,geomObj_1461] = geompj.ExtractShapes(geomObj_1434 , geompj.
  ShapeType["VERTEX"], True)
[geomObj_1462 ,geomObj_1463] = geompj.ExtractShapes(geomObj_1434 , geompj.
  ShapeType["VERTEX"], True)
[geomObj_1464 ,geomObj_1465] = geompj.ExtractShapes(geomObj_1434 , geompj.
  ShapeType["VERTEX"], True)
[geomObj_1466 ,geomObj_1467] = geompj.ExtractShapes(geomObj_1435 , geompj.
  ShapeType["VERTEX"], True)
[geomObj_1468 ,geomObj_1469] = geompj.ExtractShapes(geomObj_1435 , geompj.
  ShapeType["VERTEX"], True)
[geomObj_1470 ,geomObj_1471] = geompj.ExtractShapes(geomObj_1435 , geompj.
  ShapeType["VERTEX"], True)
[geomObj_1472 ,geomObj_1473] = geompj.ExtractShapes(geomObj_1436 , geompj.
  ShapeType["VERTEX"], True)
[geomObj_1474 ,geomObj_1475] = geompj.ExtractShapes(geomObj_1436 , geompj.
  ShapeType["VERTEX"], True)
[geomObj_1476 ,geomObj_1477] = geompj.ExtractShapes(geomObj_1436 , geompj.
  ShapeType["VERTEX"], True)
[geomObj_1478 ,geomObj_1479] = geompj.ExtractShapes(geomObj_1437 , geompj.
  ShapeType["VERTEX"], True)
[geomObj_1480 ,geomObj_1481] = geompj.ExtractShapes(geomObj_1437 , geompj.
  ShapeType["VERTEX"], True)

```

EDF R&D	code_saturne version 8.0 tutorial: Turbulence simulation in a mixing tee	code_saturne documentation Page 85/127
---------	---	--

```

[geomObj_1482,geomObj_1483] = geompj.ExtractShapes(geomObj_1438, geompj.
    ShapeType["VERTEX"], True)
[geomObj_1484,geomObj_1485] = geompj.ExtractShapes(geomObj_1438, geompj.
    ShapeType["VERTEX"], True)
[geomObj_1486,geomObj_1487] = geompj.ExtractShapes(geomObj_1439, geompj.
    ShapeType["VERTEX"], True)
[geomObj_1488,geomObj_1489] = geompj.ExtractShapes(geomObj_1440, geompj.
    ShapeType["VERTEX"], True)
[geomObj_1490,geomObj_1491] = geompj.ExtractShapes(geomObj_1441, geompj.
    ShapeType["VERTEX"], True)
geomObj_1492 = geompj.MakePlaneThreePnt(geomObj_1284, geomObj_1285,
    geomObj_1295, 10000)
geomObj_1493 = geompj.MakeProjection(geomObj_1353, geomObj_1492)
geomObj_1494 = geompj.MakeProjection(geomObj_1354, geomObj_1492)
geomObj_1495 = geompj.MakeProjection(geomObj_1355, geomObj_1492)
geomObj_1496 = geompj.MakeProjection(geomObj_1356, geomObj_1492)
geomObj_1497 = geompj.MakeProjection(geomObj_1357, geomObj_1492)
geomObj_1498 = geompj.MakeProjection(geomObj_1358, geomObj_1492)
geomObj_1499 = geompj.MakeProjection(geomObj_1359, geomObj_1492)
geomObj_1500 = geompj.MakeProjection(geomObj_1360, geomObj_1492)
geomObj_1501 = geompj.MakePlaneThreePnt(geomObj_1329, geomObj_1330,
    geomObj_1336, 10000)
geomObj_1502 = geompj.MakeProjection(geomObj_1423, geomObj_1501)
geomObj_1503 = geompj.MakeProjection(geomObj_1424, geomObj_1501)
geomObj_1504 = geompj.MakeProjection(geomObj_1425, geomObj_1501)
geomObj_1505 = geompj.MakeProjection(geomObj_1426, geomObj_1501)
geomObj_1506 = geompj.MakeProjection(geomObj_1427, geomObj_1501)
geomObj_1507 = geompj.MakeProjection(geomObj_1428, geomObj_1501)
geomObj_1508 = geompj.MakeProjection(geomObj_1429, geomObj_1501)
geomObj_1509 = geompj.MakeProjection(geomObj_1430, geomObj_1501)
geomObj_1510 = geompj.MakeTranslation(geomObj_1425, 0, 0, -25)
geomObj_1511 = geompj.MakeTranslation(geomObj_1424, 0, 0, -25)
geomObj_1512 = geompj.MakeTranslation(geomObj_1428, 0, 0, -25)
geomObj_1513 = geompj.MakeTranslation(geomObj_1427, 0, 0, -25)
geomObj_1514 = geompj.MakeArcCenter(geomObj_1275, geomObj_1426,
    geomObj_1356, False)
geomObj_1515 = geompj.MakeArcCenter(geomObj_1275, geomObj_1423,
    geomObj_1353, False)
geomObj_1516 = geompj.MakePlaneThreePnt(geomObj_1430, geomObj_1360,
    geomObj_1358, 10000)
geomObj_1517 = geompj.MakeSection(geomObj_1516, geomObj_1349, True)
geomObj_1518 = geompj.MakePartition([geomObj_1517], [geomObj_1352,
    geomObj_1422], [], [], geompj.ShapeType["EDGE"], 0, [], 0)
[geomObj_1519,geomObj_1520,geomObj_1521,geomObj_1522] = geompj.
    ExtractShapes(geomObj_1518, geompj.ShapeType["EDGE"], True)
[geomObj_1523,geomObj_1524] = geompj.ExtractShapes(geomObj_1519, geompj.
    ShapeType["VERTEX"], True)
[geomObj_1525,geomObj_1526] = geompj.ExtractShapes(geomObj_1520, geompj.
    ShapeType["VERTEX"], True)
[geomObj_1527,geomObj_1528] = geompj.ExtractShapes(geomObj_1521, geompj.
    ShapeType["VERTEX"], True)
geomObj_1529 = geompj.MakePlaneThreePnt(geomObj_1429, geomObj_1359,
    geomObj_1357, 10000)
geomObj_1530 = geompj.MakeSection(geomObj_1529, geomObj_1349, True)

```

EDF R&D	code_saturne version 8.0 tutorial: Turbulence simulation in a mixing tee	code_saturne documentation Page 86/127
---------	---	--

```

geomObj_1531 = geompy.MakePartition([geomObj_1530], [geomObj_1352,
    geomObj_1422], [], [], geompy.ShapeType["EDGE"], 0, [], 0)
[geomObj_1532, geomObj_1533, geomObj_1534, geomObj_1535] = geompy.
    ExtractShapes(geomObj_1531, geompy.ShapeType["EDGE"], True)
[geomObj_1536, geomObj_1537] = geompy.ExtractShapes(geomObj_1532, geompy.
    ShapeType["VERTEX"], True)
[geomObj_1538, geomObj_1539] = geompy.ExtractShapes(geomObj_1533, geompy.
    ShapeType["VERTEX"], True)
[geomObj_1540, geomObj_1541] = geompy.ExtractShapes(geomObj_1534, geompy.
    ShapeType["VERTEX"], True)
geomObj_1542 = geompy.MakeLineTwoPnt(geomObj_1355, geomObj_1510)
geomObj_1543 = geompy.MakeLineTwoPnt(geomObj_1354, geomObj_1511)
geomObj_1544 = geompy.MakeLineTwoPnt(geomObj_1358, geomObj_1512)
geomObj_1545 = geompy.MakeLineTwoPnt(geomObj_1357, geomObj_1513)
geomObj_1546 = geompy.MakeLineTwoPnt(geomObj_1355, geomObj_1354)
geomObj_1547 = geompy.MakeLineTwoPnt(geomObj_1355, geomObj_1356)
geomObj_1548 = geompy.MakeLineTwoPnt(geomObj_1358, geomObj_1360)
geomObj_1549 = geompy.MakeLineTwoPnt(geomObj_1354, geomObj_1353)
geomObj_1550 = geompy.MakeLineTwoPnt(geomObj_1357, geomObj_1359)
geomObj_1551 = geompy.MakeLineTwoPnt(geomObj_1358, geomObj_1357)
geomObj_1552 = geompy.MakeLineTwoPnt(geomObj_1355, geomObj_1358)
geomObj_1553 = geompy.MakeLineTwoPnt(geomObj_1354, geomObj_1357)
geomObj_1554 = geompy.MakeLineTwoPnt(geomObj_1510, geomObj_1511)
geomObj_1555 = geompy.MakeLineTwoPnt(geomObj_1510, geomObj_1426)
geomObj_1556 = geompy.MakeLineTwoPnt(geomObj_1512, geomObj_1430)
geomObj_1557 = geompy.MakeLineTwoPnt(geomObj_1511, geomObj_1423)
geomObj_1558 = geompy.MakeLineTwoPnt(geomObj_1513, geomObj_1429)
geomObj_1559 = geompy.MakeLineTwoPnt(geomObj_1512, geomObj_1513)
geomObj_1560 = geompy.MakeLineTwoPnt(geomObj_1510, geomObj_1512)
geomObj_1561 = geompy.MakeLineTwoPnt(geomObj_1511, geomObj_1513)
geomObj_1562 = geompy.MakeFaceWires([geomObj_1552, geomObj_1542,
    geomObj_1560, geomObj_1544], 0)
geomObj_1563 = geompy.MakeFaceWires([geomObj_1553, geomObj_1543,
    geomObj_1561, geomObj_1545], 0)
geomObj_1564 = geompy.MakeFaceWires([geomObj_1548, geomObj_1544,
    geomObj_1556, geomObj_1521], 0)
geomObj_1565 = geompy.MakeFaceWires([geomObj_1551, geomObj_1544,
    geomObj_1559, geomObj_1545], 0)
geomObj_1566 = geompy.MakeFaceWires([geomObj_1550, geomObj_1545,
    geomObj_1558, geomObj_1534], 0)
geomObj_1567 = geompy.MakeFaceWires([geomObj_1554, geomObj_1560,
    geomObj_1559, geomObj_1561], 0)
geomObj_1568 = geompy.MakeFaceWires([geomObj_1555, geomObj_1560,
    geomObj_1556, geomObj_1438], 0)
geomObj_1569 = geompy.MakeFaceWires([geomObj_1556, geomObj_1559,
    geomObj_1558, geomObj_1441], 0)
geomObj_1570 = geompy.MakeFaceWires([geomObj_1557, geomObj_1561,
    geomObj_1558, geomObj_1436], 0)
geomObj_1571 = geompy.MakePrismVecH(geomObj_1352, geomObj_1272, 150)
geomObj_1572 = geompy.MakePartition([geomObj_1567, geomObj_1568,
    geomObj_1569, geomObj_1570], [], [], [], geompy.ShapeType["FACE"], 0,
    [], 0)
geomObj_1573 = geompy.MakePrismVecH(geomObj_1572, geomObj_1274, 140)
geomObj_1574 = geompy.MakeFaceWires([geomObj_1300, geomObj_1301], 1)
geomObj_1575 = geompy.MakePrismVecH(geomObj_1574, geomObj_1272, 140)

```

EDF R&D	code_saturne version 8.0 tutorial: Turbulence simulation in a mixing tee	code_saturne documentation Page 87/127
---------	---	--

```

geomObj_1576 = geompy.MakeVertex(0, -420, -420)
geomObj_1577 = geompy.MakeVertex(420, 420, 420)
geomObj_1578 = geompy.MakeBoxTwoPnt(geomObj_1576, geomObj_1577)
geomObj_1579 = geompy.MakeRotation(geomObj_1578, geomObj_1273, 45*math.pi
/180.0)
geomObj_1580 = geompy.MakeCutList(geomObj_1575, [geomObj_1573,
geomObj_1579], True)
geomObj_1581 = geompy.MakePartition([geomObj_1580], [geomObj_1562,
geomObj_1563, geomObj_1564, geomObj_1565, geomObj_1566, geomObj_1349],
[], [], geompy.ShapeType["SOLID"], 0, [], 0)
geomObj_1582 = geompy.MakeCompound([geomObj_1581, geomObj_1571,
geomObj_1573])
geomObj_1583 = geompy.MakeGlueFaces(geomObj_1582, 1e-07)
geomObj_1584 = geompy.MakeVertex(-1, -120, -1)
geomObj_1585 = geompy.MakeVertex(140, 120, 140)
geomObj_1586 = geompy.MakeBoxTwoPnt(geomObj_1584, geomObj_1585)
geomObj_1587 = geompy.MakeCommonList([geomObj_1586, geomObj_1583], True)
geomObj_1588 = geompy.MakeVertex(0, 0, 0)
geomObj_1589 = geompy.MakeVectorDXDYDZ(1, 0, 0)
geomObj_1590 = geompy.MakeVectorDXDYDZ(0, 1, 0)
geomObj_1591 = geompy.MakeVectorDXDYDZ(0, 0, 1)
geomObj_1592 = geompy.MakeVertex(0, 0, 0)
geomObj_1593 = geompy.MakeVertex(0, 35, 0)
geomObj_1594 = geompy.MakeVertex(0, 70, 0)
geomObj_1595 = geompy.MakeLineTwoPnt(geomObj_1593, geomObj_1594)
geomObj_1596 = geompy.MakeRotation(geomObj_1595, geomObj_1589, 45*math.pi
/180.0)
geomObj_1597 = geompy.MakeRotation(geomObj_1593, geomObj_1589, 45*math.pi
/180.0)
geomObj_1598 = geompy.MakeRotation(geomObj_1594, geomObj_1589, 45*math.pi
/180.0)
geomObj_1599 = geompy.MakeVertex(0, -35, 0)
geomObj_1600 = geompy.MakeVertex(0, -70, 0)
geomObj_1601 = geompy.MakeLineTwoPnt(geomObj_1599, geomObj_1600)
geomObj_1602 = geompy.MakeRotation(geomObj_1601, geomObj_1589, -45*math.
pi/180.0)
geomObj_1603 = geompy.MakeRotation(geomObj_1599, geomObj_1589, -45*math.
pi/180.0)
geomObj_1604 = geompy.MakeRotation(geomObj_1600, geomObj_1589, -45*math.
pi/180.0)
geomObj_1605 = geompy.MakeLineTwoPnt(geomObj_1597, geomObj_1603)
geomObj_1606 = geompy.MakeLineTwoPnt(geomObj_1593, geomObj_1597)
geomObj_1607 = geompy.MakeLineTwoPnt(geomObj_1599, geomObj_1603)
geomObj_1608 = geompy.MakeVertex(0, 0, 70)
geomObj_1609 = geompy.MakeArc(geomObj_1594, geomObj_1608, geomObj_1600)
geomObj_1610 = geompy.MakeLineTwoPnt(geomObj_1594, geomObj_1600)
geomObj_1611 = geompy.MakeFaceWires([geomObj_1609, geomObj_1610], 1)
geomObj_1612 = geompy.MakePartition([geomObj_1611], [geomObj_1596,
geomObj_1602, geomObj_1605, geomObj_1606, geomObj_1607], [], [],
geompy.ShapeType["FACE"], 0, [], 0)
geomObj_1613 = geompy.MakeRotation(geomObj_1593, geomObj_1590, 180*math.
pi/180.0)
geomObj_1614 = geompy.MakeRotation(geomObj_1594, geomObj_1590, 180*math.
pi/180.0)

```

EDF R&D	code_saturne version 8.0 tutorial: Turbulence simulation in a mixing tee	code_saturne documentation Page 88/127
---------	---	--

```

geomObj_1615 = geompy.MakeRotation(geomObj_1599, geomObj_1590, 180*math.
    pi/180.0)
geomObj_1616 = geompy.MakeRotation(geomObj_1600, geomObj_1590, 180*math.
    pi/180.0)
geomObj_1617 = geompy.MakeRotation(geomObj_1597, geomObj_1590, 180*math.
    pi/180.0)
geomObj_1618 = geompy.MakeRotation(geomObj_1603, geomObj_1590, 180*math.
    pi/180.0)
geomObj_1619 = geompy.MakeRotation(geomObj_1598, geomObj_1590, 180*math.
    pi/180.0)
geomObj_1620 = geompy.MakeRotation(geomObj_1604, geomObj_1590, 180*math.
    pi/180.0)
geomObj_1621 = geompy.MakeRotation(geomObj_1610, geomObj_1590, 180*math.
    pi/180.0)
geomObj_1622 = geompy.MakeRotation(geomObj_1595, geomObj_1590, 180*math.
    pi/180.0)
geomObj_1623 = geompy.MakeRotation(geomObj_1596, geomObj_1590, 180*math.
    pi/180.0)
geomObj_1624 = geompy.MakeRotation(geomObj_1601, geomObj_1590, 180*math.
    pi/180.0)
geomObj_1625 = geompy.MakeRotation(geomObj_1602, geomObj_1590, 180*math.
    pi/180.0)
geomObj_1626 = geompy.MakeRotation(geomObj_1605, geomObj_1590, 180*math.
    pi/180.0)
geomObj_1627 = geompy.MakeRotation(geomObj_1606, geomObj_1590, 180*math.
    pi/180.0)
geomObj_1628 = geompy.MakeRotation(geomObj_1607, geomObj_1590, 180*math.
    pi/180.0)
geomObj_1629 = geompy.MakeRotation(geomObj_1609, geomObj_1590, 180*math.
    pi/180.0)
geomObj_1630 = geompy.MakeRotation(geomObj_1612, geomObj_1590, 180*math.
    pi/180.0)
geomObj_1631 = geompy.MakePrismVecH(geomObj_1630, geomObj_1272, 140)
geomObj_1632 = geompy.MakeCompound([geomObj_1587, geomObj_1631])
geomObj_1633 = geompy.MakePlane(geomObj_1271, geomObj_1272, 2000)
geomObj_1634 = geompy.MakeMirrorByPlane(geomObj_1632, geomObj_1633)
geomObj_1635 = geompy.MakeCompound([geomObj_1632, geomObj_1634])
geomObj_1636 = geompy.MakeGlueFaces(geomObj_1635, 1e-07)
geomObj_1637 = geompy.MakeVertex(0, 0, 0)
geomObj_1638 = geompy.MakeVectorDXDYDZ(1, 0, 0)
geomObj_1639 = geompy.MakeVectorDXDYDZ(0, 1, 0)
geomObj_1640 = geompy.MakeVectorDXDYDZ(0, 0, 1)
geomObj_1641 = geompy.MakeVertex(0, 0, 0)
geomObj_1642 = geompy.MakeVectorDXDYDZ(1, 0, 0)
geomObj_1643 = geompy.MakeVectorDXDYDZ(0, 1, 0)
geomObj_1644 = geompy.MakeVectorDXDYDZ(0, 0, 1)
geomObj_1645 = geompy.MakeVertex(0, 0, 0)
geomObj_1646 = geompy.MakeVectorDXDYDZ(1, 0, 0)
geomObj_1647 = geompy.MakeVectorDXDYDZ(0, 1, 0)
geomObj_1648 = geompy.MakeVectorDXDYDZ(0, 0, 1)
geomObj_1649 = geompy.MakeVertex(0, 0, 0)
geomObj_1650 = geompy.MakeVertex(0, 0.035, 0)
geomObj_1651 = geompy.MakeVertex(0, 0.070000000000000001, 0)
geomObj_1652 = geompy.MakeLineTwoPnt(geomObj_1650, geomObj_1651)

```

EDF R&D	code_saturne version 8.0 tutorial: Turbulence simulation in a mixing tee	code_saturne documentation Page 89/127
---------	---	--

```

geomObj_1653 = geompy.MakeRotation(geomObj_1652, geomObj_1646, 45*math.pi
/180.0)
geomObj_1654 = geompy.MakeRotation(geomObj_1650, geomObj_1646, 45*math.pi
/180.0)
geomObj_1655 = geompy.MakeRotation(geomObj_1651, geomObj_1646, 45*math.pi
/180.0)
geomObj_1656 = geompy.MakeVertex(0, -0.035, 0)
geomObj_1657 = geompy.MakeVertex(0, -0.07000000000000001, 0)
geomObj_1658 = geompy.MakeLineTwoPnt(geomObj_1656, geomObj_1657)
geomObj_1659 = geompy.MakeRotation(geomObj_1658, geomObj_1646, -45*math.
pi/180.0)
geomObj_1660 = geompy.MakeRotation(geomObj_1656, geomObj_1646, -45*math.
pi/180.0)
geomObj_1661 = geompy.MakeRotation(geomObj_1657, geomObj_1646, -45*math.
pi/180.0)
geomObj_1662 = geompy.MakeLineTwoPnt(geomObj_1654, geomObj_1660)
geomObj_1663 = geompy.MakeLineTwoPnt(geomObj_1650, geomObj_1654)
geomObj_1664 = geompy.MakeLineTwoPnt(geomObj_1656, geomObj_1660)
geomObj_1665 = geompy.MakeVertex(0, 0, 0.07000000000000001)
geomObj_1666 = geompy.MakeArc(geomObj_1651, geomObj_1665, geomObj_1657)
geomObj_1667 = geompy.MakeLineTwoPnt(geomObj_1651, geomObj_1657)
geomObj_1668 = geompy.MakeFaceWires([geomObj_1666, geomObj_1667], 1)
geomObj_1669 = geompy.MakePartition([geomObj_1668], [geomObj_1653,
geomObj_1659, geomObj_1662, geomObj_1663, geomObj_1664], [], [],
geompy.ShapeType["FACE"], 0, [], 0)
geomObj_1670 = geompy.MakeVertex(0, 0, 0)
geomObj_1671 = geompy.MakeVectorDXDYDZ(1, 0, 0)
geomObj_1672 = geompy.MakeVectorDXDYDZ(0, 1, 0)
geomObj_1673 = geompy.MakeVectorDXDYDZ(0, 0, 1)
geomObj_1674 = geompy.MakeVertex(0, 0, 0)
geomObj_1675 = geompy.MakeVertex(0, 0.025, 0)
geomObj_1676 = geompy.MakeVertex(0, 0.05, 0)
geomObj_1677 = geompy.MakeLineTwoPnt(geomObj_1675, geomObj_1676)
geomObj_1678 = geompy.MakeRotation(geomObj_1677, geomObj_1671, 45*math.pi
/180.0)
geomObj_1679 = geompy.MakeRotation(geomObj_1675, geomObj_1671, 45*math.pi
/180.0)
geomObj_1680 = geompy.MakeRotation(geomObj_1676, geomObj_1671, 45*math.pi
/180.0)
geomObj_1681 = geompy.MakeVertex(0, -0.025, 0)
geomObj_1682 = geompy.MakeVertex(0, -0.05, 0)
geomObj_1683 = geompy.MakeLineTwoPnt(geomObj_1681, geomObj_1682)
geomObj_1684 = geompy.MakeRotation(geomObj_1683, geomObj_1671, -45*math.
pi/180.0)
geomObj_1685 = geompy.MakeRotation(geomObj_1681, geomObj_1671, -45*math.
pi/180.0)
geomObj_1686 = geompy.MakeRotation(geomObj_1682, geomObj_1671, -45*math.
pi/180.0)
geomObj_1687 = geompy.MakeLineTwoPnt(geomObj_1679, geomObj_1685)
geomObj_1688 = geompy.MakeLineTwoPnt(geomObj_1675, geomObj_1679)
geomObj_1689 = geompy.MakeLineTwoPnt(geomObj_1681, geomObj_1685)
geomObj_1690 = geompy.MakeVertex(0, 0, 0.05)
geomObj_1691 = geompy.MakeArc(geomObj_1676, geomObj_1690, geomObj_1682)
geomObj_1692 = geompy.MakeLineTwoPnt(geomObj_1676, geomObj_1682)
geomObj_1693 = geompy.MakeFaceWires([geomObj_1691, geomObj_1692], 1)

```

EDF R&D	code_saturne version 8.0 tutorial: Turbulence simulation in a mixing tee	code_saturne documentation Page 90/127
---------	---	--

```

geomObj_1694 = geompy.MakePartition([geomObj_1693], [geomObj_1678,
    geomObj_1684, geomObj_1687, geomObj_1688, geomObj_1689], [], [],
    geompy.ShapeType["FACE"], 0, [], 0)
geomObj_1695 = geompy.MakeRotation(geomObj_1675, geomObj_1672, 90*math.pi
    /180.0)
geomObj_1696 = geompy.MakeRotation(geomObj_1676, geomObj_1672, 90*math.pi
    /180.0)
geomObj_1697 = geompy.MakeRotation(geomObj_1681, geomObj_1672, 90*math.pi
    /180.0)
geomObj_1698 = geompy.MakeRotation(geomObj_1682, geomObj_1672, 90*math.pi
    /180.0)
geomObj_1699 = geompy.MakeRotation(geomObj_1679, geomObj_1672, 90*math.pi
    /180.0)
geomObj_1700 = geompy.MakeRotation(geomObj_1685, geomObj_1672, 90*math.pi
    /180.0)
geomObj_1701 = geompy.MakeRotation(geomObj_1680, geomObj_1672, 90*math.pi
    /180.0)
geomObj_1702 = geompy.MakeRotation(geomObj_1686, geomObj_1672, 90*math.pi
    /180.0)
geomObj_1703 = geompy.MakeRotation(geomObj_1692, geomObj_1672, 90*math.pi
    /180.0)
geomObj_1704 = geompy.MakeRotation(geomObj_1677, geomObj_1672, 90*math.pi
    /180.0)
geomObj_1705 = geompy.MakeRotation(geomObj_1678, geomObj_1672, 90*math.pi
    /180.0)
geomObj_1706 = geompy.MakeRotation(geomObj_1683, geomObj_1672, 90*math.pi
    /180.0)
geomObj_1707 = geompy.MakeRotation(geomObj_1684, geomObj_1672, 90*math.pi
    /180.0)
geomObj_1708 = geompy.MakeRotation(geomObj_1687, geomObj_1672, 90*math.pi
    /180.0)
geomObj_1709 = geompy.MakeRotation(geomObj_1688, geomObj_1672, 90*math.pi
    /180.0)
geomObj_1710 = geompy.MakeRotation(geomObj_1689, geomObj_1672, 90*math.pi
    /180.0)
geomObj_1711 = geompy.MakeRotation(geomObj_1691, geomObj_1672, 90*math.pi
    /180.0)
geomObj_1712 = geompy.MakeRotation(geomObj_1694, geomObj_1672, 90*math.pi
    /180.0)
geomObj_1713 = geompy.MakePrismVecH(geomObj_1669, geomObj_1642, 0.14)
geomObj_1714 = geompy.MakePrismVecH(geomObj_1712, geomObj_1644, 0.14)
geomObj_1715 = geompy.MakePrismVecH(geomObj_1666, geomObj_1642, 0.14)
geomObj_1716 = geompy.MakePlane(geomObj_1641, geomObj_1642, 0.28)
geomObj_1717 = geompy.MakeRotation(geomObj_1716, geomObj_1643, 45*math.pi
    /180.0)
geomObj_1718 = geompy.MakeCommonList([geomObj_1713, geomObj_1717], True)
[geomObj_1719, geomObj_1720, geomObj_1721, geomObj_1722, geomObj_1723,
    geomObj_1724, geomObj_1725, geomObj_1726] = geompy.ExtractShapes(
    geomObj_1718, geompy.ShapeType["VERTEX"], True)
[geomObj_1727, geomObj_1728, geomObj_1729, geomObj_1730, geomObj_1731,
    geomObj_1732, geomObj_1733, geomObj_1734, geomObj_1735, geomObj_1736,
    geomObj_1737] = geompy.ExtractShapes(geomObj_1718, geompy.ShapeType["
    EDGE"], True)
[geomObj_1738, geomObj_1739] = geompy.ExtractShapes(geomObj_1727, geompy.
    ShapeType["VERTEX"], True)

```

EDF R&D	code_saturne version 8.0 tutorial: Turbulence simulation in a mixing tee	code_saturne documentation Page 91/127
---------	---	--

```

[geomObj_1740,geomObj_1741] = geompoly.ExtractShapes(geomObj_1727, geompoly.
    ShapeType["VERTEX"], True)
[geomObj_1742,geomObj_1743] = geompoly.ExtractShapes(geomObj_1727, geompoly.
    ShapeType["VERTEX"], True)
[geomObj_1744,geomObj_1745] = geompoly.ExtractShapes(geomObj_1728, geompoly.
    ShapeType["VERTEX"], True)
[geomObj_1746,geomObj_1747] = geompoly.ExtractShapes(geomObj_1728, geompoly.
    ShapeType["VERTEX"], True)
[geomObj_1748,geomObj_1749] = geompoly.ExtractShapes(geomObj_1728, geompoly.
    ShapeType["VERTEX"], True)
[geomObj_1750,geomObj_1751] = geompoly.ExtractShapes(geomObj_1729, geompoly.
    ShapeType["VERTEX"], True)
[geomObj_1752,geomObj_1753] = geompoly.ExtractShapes(geomObj_1729, geompoly.
    ShapeType["VERTEX"], True)
[geomObj_1754,geomObj_1755] = geompoly.ExtractShapes(geomObj_1729, geompoly.
    ShapeType["VERTEX"], True)
[geomObj_1756,geomObj_1757] = geompoly.ExtractShapes(geomObj_1730, geompoly.
    ShapeType["VERTEX"], True)
[geomObj_1758,geomObj_1759] = geompoly.ExtractShapes(geomObj_1730, geompoly.
    ShapeType["VERTEX"], True)
[geomObj_1760,geomObj_1761] = geompoly.ExtractShapes(geomObj_1730, geompoly.
    ShapeType["VERTEX"], True)
[geomObj_1762,geomObj_1763] = geompoly.ExtractShapes(geomObj_1731, geompoly.
    ShapeType["VERTEX"], True)
[geomObj_1764,geomObj_1765] = geompoly.ExtractShapes(geomObj_1731, geompoly.
    ShapeType["VERTEX"], True)
[geomObj_1766,geomObj_1767] = geompoly.ExtractShapes(geomObj_1731, geompoly.
    ShapeType["VERTEX"], True)
[geomObj_1768,geomObj_1769] = geompoly.ExtractShapes(geomObj_1732, geompoly.
    ShapeType["VERTEX"], True)
[geomObj_1770,geomObj_1771] = geompoly.ExtractShapes(geomObj_1732, geompoly.
    ShapeType["VERTEX"], True)
[geomObj_1772,geomObj_1773] = geompoly.ExtractShapes(geomObj_1732, geompoly.
    ShapeType["VERTEX"], True)
[geomObj_1774,geomObj_1775] = geompoly.ExtractShapes(geomObj_1733, geompoly.
    ShapeType["VERTEX"], True)
[geomObj_1776,geomObj_1777] = geompoly.ExtractShapes(geomObj_1733, geompoly.
    ShapeType["VERTEX"], True)
[geomObj_1778,geomObj_1779] = geompoly.ExtractShapes(geomObj_1734, geompoly.
    ShapeType["VERTEX"], True)
[geomObj_1780,geomObj_1781] = geompoly.ExtractShapes(geomObj_1734, geompoly.
    ShapeType["VERTEX"], True)
[geomObj_1782,geomObj_1783] = geompoly.ExtractShapes(geomObj_1735, geompoly.
    ShapeType["VERTEX"], True)
[geomObj_1784,geomObj_1785] = geompoly.ExtractShapes(geomObj_1736, geompoly.
    ShapeType["VERTEX"], True)
[geomObj_1786,geomObj_1787] = geompoly.ExtractShapes(geomObj_1737, geompoly.
    ShapeType["VERTEX"], True)
geomObj_1788 = geompoly.MakeCommonList([geomObj_1714, geomObj_1715], True)
[geomObj_1789,geomObj_1790,geomObj_1791,geomObj_1792,geomObj_1793,
    geomObj_1794,geomObj_1795,geomObj_1796] = geompoly.ExtractShapes(
    geomObj_1788, geompoly.ShapeType["VERTEX"], True)
[geomObj_1797,geomObj_1798,geomObj_1799,geomObj_1800,geomObj_1801,
    geomObj_1802,geomObj_1803,geomObj_1804,geomObj_1805,geomObj_1806,
    geomObj_1807] = geompoly.ExtractShapes(geomObj_1788, geompoly.ShapeType["

```

EDF R&D	code_saturne version 8.0 tutorial: Turbulence simulation in a mixing tee	code_saturne documentation Page 92/127
---------	---	--

```

EDGE"], True)
[geomObj_1808,geomObj_1809] = geompy.ExtractShapes(geomObj_1797, geompy.
    ShapeType["VERTEX"], True)
[geomObj_1810,geomObj_1811] = geompy.ExtractShapes(geomObj_1797, geompy.
    ShapeType["VERTEX"], True)
[geomObj_1812,geomObj_1813] = geompy.ExtractShapes(geomObj_1797, geompy.
    ShapeType["VERTEX"], True)
[geomObj_1814,geomObj_1815] = geompy.ExtractShapes(geomObj_1798, geompy.
    ShapeType["VERTEX"], True)
[geomObj_1816,geomObj_1817] = geompy.ExtractShapes(geomObj_1798, geompy.
    ShapeType["VERTEX"], True)
[geomObj_1818,geomObj_1819] = geompy.ExtractShapes(geomObj_1798, geompy.
    ShapeType["VERTEX"], True)
[geomObj_1820,geomObj_1821] = geompy.ExtractShapes(geomObj_1799, geompy.
    ShapeType["VERTEX"], True)
[geomObj_1822,geomObj_1823] = geompy.ExtractShapes(geomObj_1799, geompy.
    ShapeType["VERTEX"], True)
[geomObj_1824,geomObj_1825] = geompy.ExtractShapes(geomObj_1799, geompy.
    ShapeType["VERTEX"], True)
[geomObj_1826,geomObj_1827] = geompy.ExtractShapes(geomObj_1800, geompy.
    ShapeType["VERTEX"], True)
[geomObj_1828,geomObj_1829] = geompy.ExtractShapes(geomObj_1800, geompy.
    ShapeType["VERTEX"], True)
[geomObj_1830,geomObj_1831] = geompy.ExtractShapes(geomObj_1800, geompy.
    ShapeType["VERTEX"], True)
[geomObj_1832,geomObj_1833] = geompy.ExtractShapes(geomObj_1801, geompy.
    ShapeType["VERTEX"], True)
[geomObj_1834,geomObj_1835] = geompy.ExtractShapes(geomObj_1801, geompy.
    ShapeType["VERTEX"], True)
[geomObj_1836,geomObj_1837] = geompy.ExtractShapes(geomObj_1801, geompy.
    ShapeType["VERTEX"], True)
[geomObj_1838,geomObj_1839] = geompy.ExtractShapes(geomObj_1802, geompy.
    ShapeType["VERTEX"], True)
[geomObj_1840,geomObj_1841] = geompy.ExtractShapes(geomObj_1802, geompy.
    ShapeType["VERTEX"], True)
[geomObj_1842,geomObj_1843] = geompy.ExtractShapes(geomObj_1802, geompy.
    ShapeType["VERTEX"], True)
[geomObj_1844,geomObj_1845] = geompy.ExtractShapes(geomObj_1803, geompy.
    ShapeType["VERTEX"], True)
[geomObj_1846,geomObj_1847] = geompy.ExtractShapes(geomObj_1803, geompy.
    ShapeType["VERTEX"], True)
[geomObj_1848,geomObj_1849] = geompy.ExtractShapes(geomObj_1804, geompy.
    ShapeType["VERTEX"], True)
[geomObj_1850,geomObj_1851] = geompy.ExtractShapes(geomObj_1804, geompy.
    ShapeType["VERTEX"], True)
[geomObj_1852,geomObj_1853] = geompy.ExtractShapes(geomObj_1805, geompy.
    ShapeType["VERTEX"], True)
[geomObj_1854,geomObj_1855] = geompy.ExtractShapes(geomObj_1806, geompy.
    ShapeType["VERTEX"], True)
[geomObj_1856,geomObj_1857] = geompy.ExtractShapes(geomObj_1807, geompy.
    ShapeType["VERTEX"], True)
geomObj_1858 = geompy.MakePlaneThreePnt(geomObj_1650, geomObj_1651,
    geomObj_1661, 10000)
geomObj_1859 = geompy.MakeProjection(geomObj_1719, geomObj_1858)
geomObj_1860 = geompy.MakeProjection(geomObj_1720, geomObj_1858)

```

EDF R&D	code_saturne version 8.0 tutorial: Turbulence simulation in a mixing tee	code_saturne documentation Page 93/127
---------	---	--

```

geomObj_1861 = geompy.MakeProjection(geomObj_1721, geomObj_1858)
geomObj_1862 = geompy.MakeProjection(geomObj_1722, geomObj_1858)
geomObj_1863 = geompy.MakeProjection(geomObj_1723, geomObj_1858)
geomObj_1864 = geompy.MakeProjection(geomObj_1724, geomObj_1858)
geomObj_1865 = geompy.MakeProjection(geomObj_1725, geomObj_1858)
geomObj_1866 = geompy.MakeProjection(geomObj_1726, geomObj_1858)
geomObj_1867 = geompy.MakePlaneThreePnt(geomObj_1695, geomObj_1696,
geomObj_1702, 10000)
geomObj_1868 = geompy.MakeProjection(geomObj_1789, geomObj_1867)
geomObj_1869 = geompy.MakeProjection(geomObj_1790, geomObj_1867)
geomObj_1870 = geompy.MakeProjection(geomObj_1791, geomObj_1867)
geomObj_1871 = geompy.MakeProjection(geomObj_1792, geomObj_1867)
geomObj_1872 = geompy.MakeProjection(geomObj_1793, geomObj_1867)
geomObj_1873 = geompy.MakeProjection(geomObj_1794, geomObj_1867)
geomObj_1874 = geompy.MakeProjection(geomObj_1795, geomObj_1867)
geomObj_1875 = geompy.MakeProjection(geomObj_1796, geomObj_1867)
geomObj_1876 = geompy.MakeTranslation(geomObj_1791, 0, 0, -0.025)
geomObj_1877 = geompy.MakeTranslation(geomObj_1790, 0, 0, -0.025)
geomObj_1878 = geompy.MakeTranslation(geomObj_1794, 0, 0, -0.025)
geomObj_1879 = geompy.MakeTranslation(geomObj_1793, 0, 0, -0.025)
geomObj_1880 = geompy.MakeArcCenter(geomObj_1641, geomObj_1792,
geomObj_1722, False)
geomObj_1881 = geompy.MakeArcCenter(geomObj_1641, geomObj_1789,
geomObj_1719, False)
geomObj_1882 = geompy.MakePlaneThreePnt(geomObj_1796, geomObj_1726,
geomObj_1724, 10000)
geomObj_1883 = geompy.MakeSection(geomObj_1882, geomObj_1715, True)
geomObj_1884 = geompy.MakePartition([geomObj_1883], [geomObj_1718,
geomObj_1788], [], [], geompy.ShapeType["EDGE"], 0, [], 0)
[geomObj_1885, geomObj_1886, geomObj_1887, geomObj_1888] = geompy.
ExtractShapes(geomObj_1884, geompy.ShapeType["EDGE"], True)
[geomObj_1889, geomObj_1890] = geompy.ExtractShapes(geomObj_1885, geompy.
ShapeType["VERTEX"], True)
[geomObj_1891, geomObj_1892] = geompy.ExtractShapes(geomObj_1886, geompy.
ShapeType["VERTEX"], True)
[geomObj_1893, geomObj_1894] = geompy.ExtractShapes(geomObj_1887, geompy.
ShapeType["VERTEX"], True)
geomObj_1895 = geompy.MakePlaneThreePnt(geomObj_1795, geomObj_1725,
geomObj_1723, 10000)
geomObj_1896 = geompy.MakeSection(geomObj_1895, geomObj_1715, True)
geomObj_1897 = geompy.MakePartition([geomObj_1896], [geomObj_1718,
geomObj_1788], [], [], geompy.ShapeType["EDGE"], 0, [], 0)
[geomObj_1898, geomObj_1899, geomObj_1900, geomObj_1901] = geompy.
ExtractShapes(geomObj_1897, geompy.ShapeType["EDGE"], True)
[geomObj_1902, geomObj_1903] = geompy.ExtractShapes(geomObj_1898, geompy.
ShapeType["VERTEX"], True)
[geomObj_1904, geomObj_1905] = geompy.ExtractShapes(geomObj_1899, geompy.
ShapeType["VERTEX"], True)
[geomObj_1906, geomObj_1907] = geompy.ExtractShapes(geomObj_1900, geompy.
ShapeType["VERTEX"], True)
geomObj_1908 = geompy.MakeLineTwoPnt(geomObj_1721, geomObj_1876)
geomObj_1909 = geompy.MakeLineTwoPnt(geomObj_1720, geomObj_1877)
geomObj_1910 = geompy.MakeLineTwoPnt(geomObj_1724, geomObj_1878)
geomObj_1911 = geompy.MakeLineTwoPnt(geomObj_1723, geomObj_1879)
geomObj_1912 = geompy.MakeLineTwoPnt(geomObj_1721, geomObj_1720)

```

EDF R&D	code_saturne version 8.0 tutorial: Turbulence simulation in a mixing tee	code_saturne documentation Page 94/127
---------	---	--

```

geomObj_1913 = geompy.MakeLineTwoPnt(geomObj_1721, geomObj_1722)
geomObj_1914 = geompy.MakeLineTwoPnt(geomObj_1724, geomObj_1726)
geomObj_1915 = geompy.MakeLineTwoPnt(geomObj_1720, geomObj_1719)
geomObj_1916 = geompy.MakeLineTwoPnt(geomObj_1723, geomObj_1725)
geomObj_1917 = geompy.MakeLineTwoPnt(geomObj_1724, geomObj_1723)
geomObj_1918 = geompy.MakeLineTwoPnt(geomObj_1721, geomObj_1724)
geomObj_1919 = geompy.MakeLineTwoPnt(geomObj_1720, geomObj_1723)
geomObj_1920 = geompy.MakeLineTwoPnt(geomObj_1876, geomObj_1877)
geomObj_1921 = geompy.MakeLineTwoPnt(geomObj_1876, geomObj_1792)
geomObj_1922 = geompy.MakeLineTwoPnt(geomObj_1878, geomObj_1796)
geomObj_1923 = geompy.MakeLineTwoPnt(geomObj_1877, geomObj_1789)
geomObj_1924 = geompy.MakeLineTwoPnt(geomObj_1879, geomObj_1795)
geomObj_1925 = geompy.MakeLineTwoPnt(geomObj_1878, geomObj_1879)
geomObj_1926 = geompy.MakeLineTwoPnt(geomObj_1876, geomObj_1878)
geomObj_1927 = geompy.MakeLineTwoPnt(geomObj_1877, geomObj_1879)
geomObj_1928 = geompy.MakeFaceWires([geomObj_1918, geomObj_1908,
    geomObj_1926, geomObj_1910], 0)
geomObj_1929 = geompy.MakeFaceWires([geomObj_1919, geomObj_1909,
    geomObj_1927, geomObj_1911], 0)
geomObj_1930 = geompy.MakeFaceWires([geomObj_1914, geomObj_1910,
    geomObj_1922, geomObj_1887], 0)
geomObj_1931 = geompy.MakeFaceWires([geomObj_1917, geomObj_1910,
    geomObj_1925, geomObj_1911], 0)
geomObj_1932 = geompy.MakeFaceWires([geomObj_1916, geomObj_1911,
    geomObj_1924, geomObj_1900], 0)
geomObj_1933 = geompy.MakeFaceWires([geomObj_1920, geomObj_1926,
    geomObj_1925, geomObj_1927], 0)
geomObj_1934 = geompy.MakeFaceWires([geomObj_1921, geomObj_1926,
    geomObj_1922, geomObj_1804], 0)
geomObj_1935 = geompy.MakeFaceWires([geomObj_1922, geomObj_1925,
    geomObj_1924, geomObj_1807], 0)
geomObj_1936 = geompy.MakeFaceWires([geomObj_1923, geomObj_1927,
    geomObj_1924, geomObj_1802], 0)
geomObj_1937 = geompy.MakePrismVecH(geomObj_1718, geomObj_1638, 10.14)
geomObj_1938 = geompy.MakePartition([geomObj_1933, geomObj_1934,
    geomObj_1935, geomObj_1936], [], [], [], geompy.ShapeType["FACE"], 0,
    [], 0)
geomObj_1939 = geompy.MakePrismVecH(geomObj_1938, geomObj_1640, 0.14)
geomObj_1940 = geompy.MakeFaceWires([geomObj_1666, geomObj_1667], 1)
geomObj_1941 = geompy.MakePrismVecH(geomObj_1940, geomObj_1638, 0.14)
geomObj_1942 = geompy.MakeVertex(0, -0.42, -0.42)
geomObj_1943 = geompy.MakeVertex(0.42, 0.42, 0.42)
geomObj_1944 = geompy.MakeBoxTwoPnt(geomObj_1942, geomObj_1943)
geomObj_1945 = geompy.MakeRotation(geomObj_1944, geomObj_1639, 45*math.pi
    /180.0)
geomObj_1946 = geompy.MakeCutList(geomObj_1941, [geomObj_1939,
    geomObj_1945], True)
geomObj_1947 = geompy.MakePartition([geomObj_1946], [geomObj_1928,
    geomObj_1929, geomObj_1930, geomObj_1931, geomObj_1932, geomObj_1715],
    [], [], geompy.ShapeType["SOLID"], 0, [], 0)
geomObj_1948 = geompy.MakeCompound([geomObj_1947, geomObj_1937,
    geomObj_1939])
geomObj_1949 = geompy.MakeGlueFaces(geomObj_1948, 1e-07)
geomObj_1950 = geompy.MakeVertex(-1, -0.12, -1)
geomObj_1951 = geompy.MakeVertex(0.14, 0.12, 0.14)

```

EDF R&D	code_saturne version 8.0 tutorial: Turbulence simulation in a mixing tee	code_saturne documentation Page 95/127
---------	---	--

```

geomObj_1952 = geompy.MakeBoxTwoPnt(geomObj_1950, geomObj_1951)
geomObj_1953 = geompy.MakeCommonList([geomObj_1952, geomObj_1949], True)
geomObj_1954 = geompy.MakeVertex(0, 0, 0)
geomObj_1955 = geompy.MakeVectorDXDYDZ(1, 0, 0)
geomObj_1956 = geompy.MakeVectorDXDYDZ(0, 1, 0)
geomObj_1957 = geompy.MakeVectorDXDYDZ(0, 0, 1)
geomObj_1958 = geompy.MakeVertex(0, 0, 0)
geomObj_1959 = geompy.MakeVertex(0, 0.035, 0)
geomObj_1960 = geompy.MakeVertex(0, 0.070000000000000001, 0)
geomObj_1961 = geompy.MakeLineTwoPnt(geomObj_1959, geomObj_1960)
geomObj_1962 = geompy.MakeRotation(geomObj_1961, geomObj_1955, 45*math.pi
    /180.0)
geomObj_1963 = geompy.MakeRotation(geomObj_1959, geomObj_1955, 45*math.pi
    /180.0)
geomObj_1964 = geompy.MakeRotation(geomObj_1960, geomObj_1955, 45*math.pi
    /180.0)
geomObj_1965 = geompy.MakeVertex(0, -0.035, 0)
geomObj_1966 = geompy.MakeVertex(0, -0.070000000000000001, 0)
geomObj_1967 = geompy.MakeLineTwoPnt(geomObj_1965, geomObj_1966)
geomObj_1968 = geompy.MakeRotation(geomObj_1967, geomObj_1955, -45*math.
    pi/180.0)
geomObj_1969 = geompy.MakeRotation(geomObj_1965, geomObj_1955, -45*math.
    pi/180.0)
geomObj_1970 = geompy.MakeRotation(geomObj_1966, geomObj_1955, -45*math.
    pi/180.0)
geomObj_1971 = geompy.MakeLineTwoPnt(geomObj_1963, geomObj_1969)
geomObj_1972 = geompy.MakeLineTwoPnt(geomObj_1959, geomObj_1963)
geomObj_1973 = geompy.MakeLineTwoPnt(geomObj_1965, geomObj_1969)
geomObj_1974 = geompy.MakeVertex(0, 0, 0.070000000000000001)
geomObj_1975 = geompy.MakeArc(geomObj_1960, geomObj_1974, geomObj_1966)
geomObj_1976 = geompy.MakeLineTwoPnt(geomObj_1960, geomObj_1966)
geomObj_1977 = geompy.MakeFaceWires([geomObj_1975, geomObj_1976], 1)
geomObj_1978 = geompy.MakePartition([geomObj_1977], [geomObj_1962,
    geomObj_1968, geomObj_1971, geomObj_1972, geomObj_1973], [], [],
    geompy.ShapeType["FACE"], 0, [], 0)
geomObj_1979 = geompy.MakeRotation(geomObj_1959, geomObj_1956, 180*math.
    pi/180.0)
geomObj_1980 = geompy.MakeRotation(geomObj_1960, geomObj_1956, 180*math.
    pi/180.0)
geomObj_1981 = geompy.MakeRotation(geomObj_1965, geomObj_1956, 180*math.
    pi/180.0)
geomObj_1982 = geompy.MakeRotation(geomObj_1966, geomObj_1956, 180*math.
    pi/180.0)
geomObj_1983 = geompy.MakeRotation(geomObj_1963, geomObj_1956, 180*math.
    pi/180.0)
geomObj_1984 = geompy.MakeRotation(geomObj_1969, geomObj_1956, 180*math.
    pi/180.0)
geomObj_1985 = geompy.MakeRotation(geomObj_1964, geomObj_1956, 180*math.
    pi/180.0)
geomObj_1986 = geompy.MakeRotation(geomObj_1970, geomObj_1956, 180*math.
    pi/180.0)
geomObj_1987 = geompy.MakeRotation(geomObj_1976, geomObj_1956, 180*math.
    pi/180.0)
geomObj_1988 = geompy.MakeRotation(geomObj_1961, geomObj_1956, 180*math.
    pi/180.0)

```

EDF R&D	code_saturne version 8.0 tutorial: Turbulence simulation in a mixing tee	code_saturne documentation Page 96/127
---------	---	--

```

geomObj_1989 = geompy.MakeRotation(geomObj_1962, geomObj_1956, 180*math.
    pi/180.0)
geomObj_1990 = geompy.MakeRotation(geomObj_1967, geomObj_1956, 180*math.
    pi/180.0)
geomObj_1991 = geompy.MakeRotation(geomObj_1968, geomObj_1956, 180*math.
    pi/180.0)
geomObj_1992 = geompy.MakeRotation(geomObj_1971, geomObj_1956, 180*math.
    pi/180.0)
geomObj_1993 = geompy.MakeRotation(geomObj_1972, geomObj_1956, 180*math.
    pi/180.0)
geomObj_1994 = geompy.MakeRotation(geomObj_1973, geomObj_1956, 180*math.
    pi/180.0)
geomObj_1995 = geompy.MakeRotation(geomObj_1975, geomObj_1956, 180*math.
    pi/180.0)
geomObj_1996 = geompy.MakeRotation(geomObj_1978, geomObj_1956, 180*math.
    pi/180.0)
geomObj_1997 = geompy.MakePrismVecH(geomObj_1996, geomObj_1638, 0.14)
geomObj_1998 = geompy.MakeCompound([geomObj_1953, geomObj_1997])
geomObj_1999 = geompy.MakePlane(geomObj_1637, geomObj_1638, 2000)
geomObj_2000 = geompy.MakeMirrorByPlane(geomObj_1998, geomObj_1999)
geomObj_2001 = geompy.MakeCompound([geomObj_1998, geomObj_2000])
geomObj_2002 = geompy.MakeGlueFaces(geomObj_2001, 1e-07)
geomObj_2003 = geompy.MakeVertex(0, 0, 0)
geomObj_2004 = geompy.MakeVectorDXDYDZ(1, 0, 0)
geomObj_2005 = geompy.MakeVectorDXDYDZ(0, 1, 0)
geomObj_2006 = geompy.MakeVectorDXDYDZ(0, 0, 1)
geomObj_2007 = geompy.MakeVertex(0, 0, 0)
geomObj_2008 = geompy.MakeVectorDXDYDZ(1, 0, 0)
geomObj_2009 = geompy.MakeVectorDXDYDZ(0, 1, 0)
geomObj_2010 = geompy.MakeVectorDXDYDZ(0, 0, 1)
geomObj_2011 = geompy.MakeVertex(0, 0, 0)
geomObj_2012 = geompy.MakeVectorDXDYDZ(1, 0, 0)
geomObj_2013 = geompy.MakeVectorDXDYDZ(0, 1, 0)
geomObj_2014 = geompy.MakeVectorDXDYDZ(0, 0, 1)
geomObj_2015 = geompy.MakeVertex(0, 0, 0)
geomObj_2016 = geompy.MakeVertex(0, 0.035, 0)
geomObj_2017 = geompy.MakeVertex(0, 0.070000000000000001, 0)
geomObj_2018 = geompy.MakeLineTwoPnt(geomObj_2016, geomObj_2017)
geomObj_2019 = geompy.MakeRotation(geomObj_2018, geomObj_2012, 45*math.pi
    /180.0)
geomObj_2020 = geompy.MakeRotation(geomObj_2016, geomObj_2012, 45*math.pi
    /180.0)
geomObj_2021 = geompy.MakeRotation(geomObj_2017, geomObj_2012, 45*math.pi
    /180.0)
geomObj_2022 = geompy.MakeVertex(0, -0.035, 0)
geomObj_2023 = geompy.MakeVertex(0, -0.070000000000000001, 0)
geomObj_2024 = geompy.MakeLineTwoPnt(geomObj_2022, geomObj_2023)
geomObj_2025 = geompy.MakeRotation(geomObj_2024, geomObj_2012, -45*math.
    pi/180.0)
geomObj_2026 = geompy.MakeRotation(geomObj_2022, geomObj_2012, -45*math.
    pi/180.0)
geomObj_2027 = geompy.MakeRotation(geomObj_2023, geomObj_2012, -45*math.
    pi/180.0)
geomObj_2028 = geompy.MakeLineTwoPnt(geomObj_2020, geomObj_2026)
geomObj_2029 = geompy.MakeLineTwoPnt(geomObj_2016, geomObj_2020)

```

EDF R&D	code_saturne version 8.0 tutorial: Turbulence simulation in a mixing tee	code_saturne documentation Page 97/127
---------	---	--

```

geomObj_2030 = geompy.MakeLineTwoPnt(geomObj_2022 , geomObj_2026)
geomObj_2031 = geompy.MakeVertex(0 , 0 , 0.070000000000000001)
geomObj_2032 = geompy.MakeArc(geomObj_2017 , geomObj_2031 , geomObj_2023)
geomObj_2033 = geompy.MakeLineTwoPnt(geomObj_2017 , geomObj_2023)
geomObj_2034 = geompy.MakeFaceWires([geomObj_2032 , geomObj_2033] , 1)
geomObj_2035 = geompy.MakePartition([geomObj_2034] , [geomObj_2019 ,
    geomObj_2025 , geomObj_2028 , geomObj_2029 , geomObj_2030] , [], [] ,
    geompy.ShapeType["FACE"] , 0 , [], 0)
geomObj_2036 = geompy.MakeVertex(0 , 0 , 0)
geomObj_2037 = geompy.MakeVectorDXDYDZ(1 , 0 , 0)
geomObj_2038 = geompy.MakeVectorDXDYDZ(0 , 1 , 0)
geomObj_2039 = geompy.MakeVectorDXDYDZ(0 , 0 , 1)
geomObj_2040 = geompy.MakeVertex(0 , 0 , 0)
geomObj_2041 = geompy.MakeVertex(0 , 0.025 , 0)
geomObj_2042 = geompy.MakeVertex(0 , 0.05 , 0)
geomObj_2043 = geompy.MakeLineTwoPnt(geomObj_2041 , geomObj_2042)
geomObj_2044 = geompy.MakeRotation(geomObj_2043 , geomObj_2037 , 45*math.pi
    /180.0)
geomObj_2045 = geompy.MakeRotation(geomObj_2041 , geomObj_2037 , 45*math.pi
    /180.0)
geomObj_2046 = geompy.MakeRotation(geomObj_2042 , geomObj_2037 , 45*math.pi
    /180.0)
geomObj_2047 = geompy.MakeVertex(0 , -0.025 , 0)
geomObj_2048 = geompy.MakeVertex(0 , -0.05 , 0)
geomObj_2049 = geompy.MakeLineTwoPnt(geomObj_2047 , geomObj_2048)
geomObj_2050 = geompy.MakeRotation(geomObj_2049 , geomObj_2037 , -45*math.
    pi/180.0)
geomObj_2051 = geompy.MakeRotation(geomObj_2047 , geomObj_2037 , -45*math.
    pi/180.0)
geomObj_2052 = geompy.MakeRotation(geomObj_2048 , geomObj_2037 , -45*math.
    pi/180.0)
geomObj_2053 = geompy.MakeLineTwoPnt(geomObj_2045 , geomObj_2051)
geomObj_2054 = geompy.MakeLineTwoPnt(geomObj_2041 , geomObj_2045)
geomObj_2055 = geompy.MakeLineTwoPnt(geomObj_2047 , geomObj_2051)
geomObj_2056 = geompy.MakeVertex(0 , 0 , 0.05)
geomObj_2057 = geompy.MakeArc(geomObj_2042 , geomObj_2056 , geomObj_2048)
geomObj_2058 = geompy.MakeLineTwoPnt(geomObj_2042 , geomObj_2048)
geomObj_2059 = geompy.MakeFaceWires([geomObj_2057 , geomObj_2058] , 1)
geomObj_2060 = geompy.MakePartition([geomObj_2059] , [geomObj_2044 ,
    geomObj_2050 , geomObj_2053 , geomObj_2054 , geomObj_2055] , [], [] ,
    geompy.ShapeType["FACE"] , 0 , [], 0)
geomObj_2061 = geompy.MakeRotation(geomObj_2041 , geomObj_2038 , 90*math.pi
    /180.0)
geomObj_2062 = geompy.MakeRotation(geomObj_2042 , geomObj_2038 , 90*math.pi
    /180.0)
geomObj_2063 = geompy.MakeRotation(geomObj_2047 , geomObj_2038 , 90*math.pi
    /180.0)
geomObj_2064 = geompy.MakeRotation(geomObj_2048 , geomObj_2038 , 90*math.pi
    /180.0)
geomObj_2065 = geompy.MakeRotation(geomObj_2045 , geomObj_2038 , 90*math.pi
    /180.0)
geomObj_2066 = geompy.MakeRotation(geomObj_2051 , geomObj_2038 , 90*math.pi
    /180.0)
geomObj_2067 = geompy.MakeRotation(geomObj_2046 , geomObj_2038 , 90*math.pi
    /180.0)

```

EDF R&D	code_saturne version 8.0 tutorial: Turbulence simulation in a mixing tee	code_saturne documentation Page 98/127
---------	---	--

```

geomObj_2068 = geompy.MakeRotation(geomObj_2052, geomObj_2038, 90*math.pi
/180.0)
geomObj_2069 = geompy.MakeRotation(geomObj_2058, geomObj_2038, 90*math.pi
/180.0)
geomObj_2070 = geompy.MakeRotation(geomObj_2043, geomObj_2038, 90*math.pi
/180.0)
geomObj_2071 = geompy.MakeRotation(geomObj_2044, geomObj_2038, 90*math.pi
/180.0)
geomObj_2072 = geompy.MakeRotation(geomObj_2049, geomObj_2038, 90*math.pi
/180.0)
geomObj_2073 = geompy.MakeRotation(geomObj_2050, geomObj_2038, 90*math.pi
/180.0)
geomObj_2074 = geompy.MakeRotation(geomObj_2053, geomObj_2038, 90*math.pi
/180.0)
geomObj_2075 = geompy.MakeRotation(geomObj_2054, geomObj_2038, 90*math.pi
/180.0)
geomObj_2076 = geompy.MakeRotation(geomObj_2055, geomObj_2038, 90*math.pi
/180.0)
geomObj_2077 = geompy.MakeRotation(geomObj_2057, geomObj_2038, 90*math.pi
/180.0)
geomObj_2078 = geompy.MakeRotation(geomObj_2060, geomObj_2038, 90*math.pi
/180.0)
geomObj_2079 = geompy.MakePrismVecH(geomObj_2035, geomObj_2008, 0.14)
geomObj_2080 = geompy.MakePrismVecH(geomObj_2078, geomObj_2010, 0.14)
geomObj_2081 = geompy.MakePrismVecH(geomObj_2032, geomObj_2008, 0.14)
geomObj_2082 = geompy.MakePlane(geomObj_2007, geomObj_2008, 0.28)
geomObj_2083 = geompy.MakeRotation(geomObj_2082, geomObj_2009, 45*math.pi
/180.0)
geomObj_2084 = geompy.MakeCommonList([geomObj_2079, geomObj_2083], True)
[geomObj_2085, geomObj_2086, geomObj_2087, geomObj_2088, geomObj_2089,
geomObj_2090, geomObj_2091, geomObj_2092] = geompy.ExtractShapes(
geomObj_2084, geompy.ShapeType["VERTEX"], True)
[geomObj_2093, geomObj_2094, geomObj_2095, geomObj_2096, geomObj_2097,
geomObj_2098, geomObj_2099, geomObj_2100, geomObj_2101, geomObj_2102,
geomObj_2103] = geompy.ExtractShapes(geomObj_2084, geompy.ShapeType["
EDGE"], True)
[geomObj_2104, geomObj_2105] = geompy.ExtractShapes(geomObj_2093, geompy.
ShapeType["VERTEX"], True)
[geomObj_2106, geomObj_2107] = geompy.ExtractShapes(geomObj_2093, geompy.
ShapeType["VERTEX"], True)
[geomObj_2108, geomObj_2109] = geompy.ExtractShapes(geomObj_2093, geompy.
ShapeType["VERTEX"], True)
[geomObj_2110, geomObj_2111] = geompy.ExtractShapes(geomObj_2094, geompy.
ShapeType["VERTEX"], True)
[geomObj_2112, geomObj_2113] = geompy.ExtractShapes(geomObj_2094, geompy.
ShapeType["VERTEX"], True)
[geomObj_2114, geomObj_2115] = geompy.ExtractShapes(geomObj_2094, geompy.
ShapeType["VERTEX"], True)
[geomObj_2116, geomObj_2117] = geompy.ExtractShapes(geomObj_2095, geompy.
ShapeType["VERTEX"], True)
[geomObj_2118, geomObj_2119] = geompy.ExtractShapes(geomObj_2095, geompy.
ShapeType["VERTEX"], True)
[geomObj_2120, geomObj_2121] = geompy.ExtractShapes(geomObj_2095, geompy.
ShapeType["VERTEX"], True)

```

EDF R&D	code_saturne version 8.0 tutorial: Turbulence simulation in a mixing tee	code_saturne documentation Page 99/127
---------	---	--

```

[geomObj_2122,geomObj_2123] = geompj.ExtractShapes(geomObj_2096, geompj.
    ShapeType["VERTEX"], True)
[geomObj_2124,geomObj_2125] = geompj.ExtractShapes(geomObj_2096, geompj.
    ShapeType["VERTEX"], True)
[geomObj_2126,geomObj_2127] = geompj.ExtractShapes(geomObj_2096, geompj.
    ShapeType["VERTEX"], True)
[geomObj_2128,geomObj_2129] = geompj.ExtractShapes(geomObj_2097, geompj.
    ShapeType["VERTEX"], True)
[geomObj_2130,geomObj_2131] = geompj.ExtractShapes(geomObj_2097, geompj.
    ShapeType["VERTEX"], True)
[geomObj_2132,geomObj_2133] = geompj.ExtractShapes(geomObj_2097, geompj.
    ShapeType["VERTEX"], True)
[geomObj_2134,geomObj_2135] = geompj.ExtractShapes(geomObj_2098, geompj.
    ShapeType["VERTEX"], True)
[geomObj_2136,geomObj_2137] = geompj.ExtractShapes(geomObj_2098, geompj.
    ShapeType["VERTEX"], True)
[geomObj_2138,geomObj_2139] = geompj.ExtractShapes(geomObj_2098, geompj.
    ShapeType["VERTEX"], True)
[geomObj_2140,geomObj_2141] = geompj.ExtractShapes(geomObj_2099, geompj.
    ShapeType["VERTEX"], True)
[geomObj_2142,geomObj_2143] = geompj.ExtractShapes(geomObj_2099, geompj.
    ShapeType["VERTEX"], True)
[geomObj_2144,geomObj_2145] = geompj.ExtractShapes(geomObj_2100, geompj.
    ShapeType["VERTEX"], True)
[geomObj_2146,geomObj_2147] = geompj.ExtractShapes(geomObj_2100, geompj.
    ShapeType["VERTEX"], True)
[geomObj_2148,geomObj_2149] = geompj.ExtractShapes(geomObj_2101, geompj.
    ShapeType["VERTEX"], True)
[geomObj_2150,geomObj_2151] = geompj.ExtractShapes(geomObj_2102, geompj.
    ShapeType["VERTEX"], True)
[geomObj_2152,geomObj_2153] = geompj.ExtractShapes(geomObj_2103, geompj.
    ShapeType["VERTEX"], True)
geomObj_2154 = geompj.MakeCommonList([geomObj_2080, geomObj_2081], True)
[geomObj_2155,geomObj_2156,geomObj_2157,geomObj_2158,geomObj_2159,
    geomObj_2160,geomObj_2161,geomObj_2162] = geompj.ExtractShapes(
    geomObj_2154, geompj.ShapeType["VERTEX"], True)
[geomObj_2163,geomObj_2164,geomObj_2165,geomObj_2166,geomObj_2167,
    geomObj_2168,geomObj_2169,geomObj_2170,geomObj_2171,geomObj_2172,
    geomObj_2173] = geompj.ExtractShapes(geomObj_2154, geompj.ShapeType["
    EDGE"], True)
[geomObj_2174,geomObj_2175] = geompj.ExtractShapes(geomObj_2163, geompj.
    ShapeType["VERTEX"], True)
[geomObj_2176,geomObj_2177] = geompj.ExtractShapes(geomObj_2163, geompj.
    ShapeType["VERTEX"], True)
[geomObj_2178,geomObj_2179] = geompj.ExtractShapes(geomObj_2163, geompj.
    ShapeType["VERTEX"], True)
[geomObj_2180,geomObj_2181] = geompj.ExtractShapes(geomObj_2164, geompj.
    ShapeType["VERTEX"], True)
[geomObj_2182,geomObj_2183] = geompj.ExtractShapes(geomObj_2164, geompj.
    ShapeType["VERTEX"], True)
[geomObj_2184,geomObj_2185] = geompj.ExtractShapes(geomObj_2164, geompj.
    ShapeType["VERTEX"], True)
[geomObj_2186,geomObj_2187] = geompj.ExtractShapes(geomObj_2165, geompj.
    ShapeType["VERTEX"], True)

```

```

[geomObj_2188 ,geomObj_2189 ] = geompy.ExtractShapes(geomObj_2165 , geompy .
    ShapeType[" VERTEX" ], True)
[geomObj_2190 ,geomObj_2191 ] = geompy.ExtractShapes(geomObj_2165 , geompy .
    ShapeType[" VERTEX" ], True)
[geomObj_2192 ,geomObj_2193 ] = geompy.ExtractShapes(geomObj_2166 , geompy .
    ShapeType[" VERTEX" ], True)
[geomObj_2194 ,geomObj_2195 ] = geompy.ExtractShapes(geomObj_2166 , geompy .
    ShapeType[" VERTEX" ], True)
[geomObj_2196 ,geomObj_2197 ] = geompy.ExtractShapes(geomObj_2166 , geompy .
    ShapeType[" VERTEX" ], True)
[geomObj_2198 ,geomObj_2199 ] = geompy.ExtractShapes(geomObj_2167 , geompy .
    ShapeType[" VERTEX" ], True)
[geomObj_2200 ,geomObj_2201 ] = geompy.ExtractShapes(geomObj_2167 , geompy .
    ShapeType[" VERTEX" ], True)
[geomObj_2202 ,geomObj_2203 ] = geompy.ExtractShapes(geomObj_2167 , geompy .
    ShapeType[" VERTEX" ], True)
[geomObj_2204 ,geomObj_2205 ] = geompy.ExtractShapes(geomObj_2168 , geompy .
    ShapeType[" VERTEX" ], True)
[geomObj_2206 ,geomObj_2207 ] = geompy.ExtractShapes(geomObj_2168 , geompy .
    ShapeType[" VERTEX" ], True)
[geomObj_2208 ,geomObj_2209 ] = geompy.ExtractShapes(geomObj_2168 , geompy .
    ShapeType[" VERTEX" ], True)
[geomObj_2210 ,geomObj_2211 ] = geompy.ExtractShapes(geomObj_2169 , geompy .
    ShapeType[" VERTEX" ], True)
[geomObj_2212 ,geomObj_2213 ] = geompy.ExtractShapes(geomObj_2169 , geompy .
    ShapeType[" VERTEX" ], True)
[geomObj_2214 ,geomObj_2215 ] = geompy.ExtractShapes(geomObj_2170 , geompy .
    ShapeType[" VERTEX" ], True)
[geomObj_2216 ,geomObj_2217 ] = geompy.ExtractShapes(geomObj_2170 , geompy .
    ShapeType[" VERTEX" ], True)
[geomObj_2218 ,geomObj_2219 ] = geompy.ExtractShapes(geomObj_2171 , geompy .
    ShapeType[" VERTEX" ], True)
[geomObj_2220 ,geomObj_2221 ] = geompy.ExtractShapes(geomObj_2172 , geompy .
    ShapeType[" VERTEX" ], True)
[geomObj_2222 ,geomObj_2223 ] = geompy.ExtractShapes(geomObj_2173 , geompy .
    ShapeType[" VERTEX" ], True)
geomObj_2224 = geompy.MakePlaneThreePnt(geomObj_2016 , geomObj_2017 ,
    geomObj_2027 , 10000)
geomObj_2225 = geompy.MakeProjection(geomObj_2085 , geomObj_2224)
geomObj_2226 = geompy.MakeProjection(geomObj_2086 , geomObj_2224)
geomObj_2227 = geompy.MakeProjection(geomObj_2087 , geomObj_2224)
geomObj_2228 = geompy.MakeProjection(geomObj_2088 , geomObj_2224)
geomObj_2229 = geompy.MakeProjection(geomObj_2089 , geomObj_2224)
geomObj_2230 = geompy.MakeProjection(geomObj_2090 , geomObj_2224)
geomObj_2231 = geompy.MakeProjection(geomObj_2091 , geomObj_2224)
geomObj_2232 = geompy.MakeProjection(geomObj_2092 , geomObj_2224)
geomObj_2233 = geompy.MakePlaneThreePnt(geomObj_2061 , geomObj_2062 ,
    geomObj_2068 , 10000)
geomObj_2234 = geompy.MakeProjection(geomObj_2155 , geomObj_2233)
geomObj_2235 = geompy.MakeProjection(geomObj_2156 , geomObj_2233)
geomObj_2236 = geompy.MakeProjection(geomObj_2157 , geomObj_2233)
geomObj_2237 = geompy.MakeProjection(geomObj_2158 , geomObj_2233)
geomObj_2238 = geompy.MakeProjection(geomObj_2159 , geomObj_2233)
geomObj_2239 = geompy.MakeProjection(geomObj_2160 , geomObj_2233)
geomObj_2240 = geompy.MakeProjection(geomObj_2161 , geomObj_2233)

```



```

geomObj_2241 = geompy.MakeProjection(geomObj_2162 , geomObj_2233)
geomObj_2242 = geompy.MakeTranslation(geomObj_2157 , 0 , 0 , -0.025)
geomObj_2243 = geompy.MakeTranslation(geomObj_2156 , 0 , 0 , -0.025)
geomObj_2244 = geompy.MakeTranslation(geomObj_2160 , 0 , 0 , -0.025)
geomObj_2245 = geompy.MakeTranslation(geomObj_2159 , 0 , 0 , -0.025)
geomObj_2246 = geompy.MakeArcCenter(geomObj_2007 , geomObj_2158 ,
    geomObj_2088 , False)
geomObj_2247 = geompy.MakeArcCenter(geomObj_2007 , geomObj_2155 ,
    geomObj_2085 , False)
geomObj_2248 = geompy.MakePlaneThreePnt(geomObj_2162 , geomObj_2092 ,
    geomObj_2090 , 10000)
geomObj_2249 = geompy.MakeSection(geomObj_2248 , geomObj_2081 , True)
geomObj_2250 = geompy.MakePartition([geomObj_2249] , [geomObj_2084 ,
    geomObj_2154] , [], [], geompy.ShapeType["EDGE"] , 0 , [], 0)
[geomObj_2251 , geomObj_2252 , geomObj_2253 , geomObj_2254] = geompy.
    ExtractShapes(geomObj_2250 , geompy.ShapeType["EDGE"] , True)
[geomObj_2255 , geomObj_2256] = geompy.ExtractShapes(geomObj_2251 , geompy.
    ShapeType["VERTEX"] , True)
[geomObj_2257 , geomObj_2258] = geompy.ExtractShapes(geomObj_2252 , geompy.
    ShapeType["VERTEX"] , True)
[geomObj_2259 , geomObj_2260] = geompy.ExtractShapes(geomObj_2253 , geompy.
    ShapeType["VERTEX"] , True)
geomObj_2261 = geompy.MakePlaneThreePnt(geomObj_2161 , geomObj_2091 ,
    geomObj_2089 , 10000)
geomObj_2262 = geompy.MakeSection(geomObj_2261 , geomObj_2081 , True)
geomObj_2263 = geompy.MakePartition([geomObj_2262] , [geomObj_2084 ,
    geomObj_2154] , [], [], geompy.ShapeType["EDGE"] , 0 , [], 0)
[geomObj_2264 , geomObj_2265 , geomObj_2266 , geomObj_2267] = geompy.
    ExtractShapes(geomObj_2263 , geompy.ShapeType["EDGE"] , True)
[geomObj_2268 , geomObj_2269] = geompy.ExtractShapes(geomObj_2264 , geompy.
    ShapeType["VERTEX"] , True)
[geomObj_2270 , geomObj_2271] = geompy.ExtractShapes(geomObj_2265 , geompy.
    ShapeType["VERTEX"] , True)
[geomObj_2272 , geomObj_2273] = geompy.ExtractShapes(geomObj_2266 , geompy.
    ShapeType["VERTEX"] , True)
geomObj_2274 = geompy.MakeLineTwoPnt(geomObj_2087 , geomObj_2242)
geomObj_2275 = geompy.MakeLineTwoPnt(geomObj_2086 , geomObj_2243)
geomObj_2276 = geompy.MakeLineTwoPnt(geomObj_2090 , geomObj_2244)
geomObj_2277 = geompy.MakeLineTwoPnt(geomObj_2089 , geomObj_2245)
geomObj_2278 = geompy.MakeLineTwoPnt(geomObj_2087 , geomObj_2086)
geomObj_2279 = geompy.MakeLineTwoPnt(geomObj_2087 , geomObj_2088)
geomObj_2280 = geompy.MakeLineTwoPnt(geomObj_2090 , geomObj_2092)
geomObj_2281 = geompy.MakeLineTwoPnt(geomObj_2086 , geomObj_2085)
geomObj_2282 = geompy.MakeLineTwoPnt(geomObj_2089 , geomObj_2091)
geomObj_2283 = geompy.MakeLineTwoPnt(geomObj_2090 , geomObj_2089)
geomObj_2284 = geompy.MakeLineTwoPnt(geomObj_2087 , geomObj_2090)
geomObj_2285 = geompy.MakeLineTwoPnt(geomObj_2086 , geomObj_2089)
geomObj_2286 = geompy.MakeLineTwoPnt(geomObj_2242 , geomObj_2243)
geomObj_2287 = geompy.MakeLineTwoPnt(geomObj_2242 , geomObj_2158)
geomObj_2288 = geompy.MakeLineTwoPnt(geomObj_2244 , geomObj_2162)
geomObj_2289 = geompy.MakeLineTwoPnt(geomObj_2243 , geomObj_2155)
geomObj_2290 = geompy.MakeLineTwoPnt(geomObj_2245 , geomObj_2161)
geomObj_2291 = geompy.MakeLineTwoPnt(geomObj_2244 , geomObj_2245)
geomObj_2292 = geompy.MakeLineTwoPnt(geomObj_2242 , geomObj_2244)
geomObj_2293 = geompy.MakeLineTwoPnt(geomObj_2243 , geomObj_2245)

```

EDF R&D	code_saturne version 8.0 tutorial: Turbulence simulation in a mixing tee	code_saturne documentation Page 102/127
---------	---	---

```

geomObj_2294 = geompy.MakeFaceWires([geomObj_2284, geomObj_2274,
    geomObj_2292, geomObj_2276], 0)
geomObj_2295 = geompy.MakeFaceWires([geomObj_2285, geomObj_2275,
    geomObj_2293, geomObj_2277], 0)
geomObj_2296 = geompy.MakeFaceWires([geomObj_2280, geomObj_2276,
    geomObj_2288, geomObj_2253], 0)
geomObj_2297 = geompy.MakeFaceWires([geomObj_2283, geomObj_2276,
    geomObj_2291, geomObj_2277], 0)
geomObj_2298 = geompy.MakeFaceWires([geomObj_2282, geomObj_2277,
    geomObj_2290, geomObj_2266], 0)
geomObj_2299 = geompy.MakeFaceWires([geomObj_2286, geomObj_2292,
    geomObj_2291, geomObj_2293], 0)
geomObj_2300 = geompy.MakeFaceWires([geomObj_2287, geomObj_2292,
    geomObj_2288, geomObj_2170], 0)
geomObj_2301 = geompy.MakeFaceWires([geomObj_2288, geomObj_2291,
    geomObj_2290, geomObj_2173], 0)
geomObj_2302 = geompy.MakeFaceWires([geomObj_2289, geomObj_2293,
    geomObj_2290, geomObj_2168], 0)
geomObj_2303 = geompy.MakePrismVecH(geomObj_2084, geomObj_2004, 10.14)
geomObj_2304 = geompy.MakePartition([geomObj_2299, geomObj_2300,
    geomObj_2301, geomObj_2302], [], [], [], geompy.ShapeType["FACE"], 0,
    [], 0)
geomObj_2305 = geompy.MakePrismVecH(geomObj_2304, geomObj_2006, 0.14)
geomObj_2306 = geompy.MakeFaceWires([geomObj_2032, geomObj_2033], 1)
geomObj_2307 = geompy.MakePrismVecH(geomObj_2306, geomObj_2004, 0.14)
geomObj_2308 = geompy.MakeVertex(0, -0.42, -0.42)
geomObj_2309 = geompy.MakeVertex(0.42, 0.42, 0.42)
geomObj_2310 = geompy.MakeBoxTwoPnt(geomObj_2308, geomObj_2309)
geomObj_2311 = geompy.MakeRotation(geomObj_2310, geomObj_2005, 45*math.pi
    /180.0)
geomObj_2312 = geompy.MakeCutList(geomObj_2307, [geomObj_2305,
    geomObj_2311], True)
geomObj_2313 = geompy.MakePartition([geomObj_2312], [geomObj_2294,
    geomObj_2295, geomObj_2296, geomObj_2297, geomObj_2298, geomObj_2081],
    [], [], geompy.ShapeType["SOLID"], 0, [], 0)
geomObj_2314 = geompy.MakeCompound([geomObj_2313, geomObj_2303,
    geomObj_2305])
geomObj_2315 = geompy.MakeGlueFaces(geomObj_2314, 1e-07)
geomObj_2316 = geompy.MakeVertex(-1, -0.12, -1)
geomObj_2317 = geompy.MakeVertex(0.14, 0.12, 0.14)
geomObj_2318 = geompy.MakeBoxTwoPnt(geomObj_2316, geomObj_2317)
geomObj_2319 = geompy.MakeCommonList([geomObj_2318, geomObj_2315], True)
geomObj_2320 = geompy.MakeVertex(0, 0, 0)
geomObj_2321 = geompy.MakeVectorDXDYDZ(1, 0, 0)
geomObj_2322 = geompy.MakeVectorDXDYDZ(0, 1, 0)
geomObj_2323 = geompy.MakeVectorDXDYDZ(0, 0, 1)
geomObj_2324 = geompy.MakeVertex(0, 0, 0)
geomObj_2325 = geompy.MakeVertex(0, 0.035, 0)
geomObj_2326 = geompy.MakeVertex(0, 0.07000000000000001, 0)
geomObj_2327 = geompy.MakeLineTwoPnt(geomObj_2325, geomObj_2326)
geomObj_2328 = geompy.MakeRotation(geomObj_2327, geomObj_2321, 45*math.pi
    /180.0)
geomObj_2329 = geompy.MakeRotation(geomObj_2325, geomObj_2321, 45*math.pi
    /180.0)

```

EDF R&D	code_saturne version 8.0 tutorial: Turbulence simulation in a mixing tee	code_saturne documentation Page 103/127
---------	---	---

```

geomObj_2330 = geompy.MakeRotation(geomObj_2326 , geomObj_2321 , 45*math.pi
/180.0)
geomObj_2331 = geompy.MakeVertex(0 , -0.035, 0)
geomObj_2332 = geompy.MakeVertex(0 , -0.07000000000000001, 0)
geomObj_2333 = geompy.MakeLineTwoPnt(geomObj_2331 , geomObj_2332)
geomObj_2334 = geompy.MakeRotation(geomObj_2333 , geomObj_2321 , -45*math.
pi/180.0)
geomObj_2335 = geompy.MakeRotation(geomObj_2331 , geomObj_2321 , -45*math.
pi/180.0)
geomObj_2336 = geompy.MakeRotation(geomObj_2332 , geomObj_2321 , -45*math.
pi/180.0)
geomObj_2337 = geompy.MakeLineTwoPnt(geomObj_2329 , geomObj_2335)
geomObj_2338 = geompy.MakeLineTwoPnt(geomObj_2325 , geomObj_2329)
geomObj_2339 = geompy.MakeLineTwoPnt(geomObj_2331 , geomObj_2335)
geomObj_2340 = geompy.MakeVertex(0 , 0 , 0.07000000000000001)
geomObj_2341 = geompy.MakeArc(geomObj_2326 , geomObj_2340 , geomObj_2332)
geomObj_2342 = geompy.MakeLineTwoPnt(geomObj_2326 , geomObj_2332)
geomObj_2343 = geompy.MakeFaceWires([geomObj_2341 , geomObj_2342] , 1)
geomObj_2344 = geompy.MakePartition([geomObj_2343] , [geomObj_2328 ,
geomObj_2334 , geomObj_2337 , geomObj_2338 , geomObj_2339] , [], [],
geompy.ShapeType["FACE"] , 0 , [], 0)
geomObj_2345 = geompy.MakeRotation(geomObj_2325 , geomObj_2322 , 180*math.
pi/180.0)
geomObj_2346 = geompy.MakeRotation(geomObj_2326 , geomObj_2322 , 180*math.
pi/180.0)
geomObj_2347 = geompy.MakeRotation(geomObj_2331 , geomObj_2322 , 180*math.
pi/180.0)
geomObj_2348 = geompy.MakeRotation(geomObj_2332 , geomObj_2322 , 180*math.
pi/180.0)
geomObj_2349 = geompy.MakeRotation(geomObj_2329 , geomObj_2322 , 180*math.
pi/180.0)
geomObj_2350 = geompy.MakeRotation(geomObj_2335 , geomObj_2322 , 180*math.
pi/180.0)
geomObj_2351 = geompy.MakeRotation(geomObj_2330 , geomObj_2322 , 180*math.
pi/180.0)
geomObj_2352 = geompy.MakeRotation(geomObj_2336 , geomObj_2322 , 180*math.
pi/180.0)
geomObj_2353 = geompy.MakeRotation(geomObj_2342 , geomObj_2322 , 180*math.
pi/180.0)
geomObj_2354 = geompy.MakeRotation(geomObj_2327 , geomObj_2322 , 180*math.
pi/180.0)
geomObj_2355 = geompy.MakeRotation(geomObj_2328 , geomObj_2322 , 180*math.
pi/180.0)
geomObj_2356 = geompy.MakeRotation(geomObj_2333 , geomObj_2322 , 180*math.
pi/180.0)
geomObj_2357 = geompy.MakeRotation(geomObj_2334 , geomObj_2322 , 180*math.
pi/180.0)
geomObj_2358 = geompy.MakeRotation(geomObj_2337 , geomObj_2322 , 180*math.
pi/180.0)
geomObj_2359 = geompy.MakeRotation(geomObj_2338 , geomObj_2322 , 180*math.
pi/180.0)
geomObj_2360 = geompy.MakeRotation(geomObj_2339 , geomObj_2322 , 180*math.
pi/180.0)
geomObj_2361 = geompy.MakeRotation(geomObj_2341 , geomObj_2322 , 180*math.
pi/180.0)

```



```

geomObj_2362 = geompy.MakeRotation(geomObj_2344 , geomObj_2322 , 180*math.
    pi/180.0)
geomObj_2363 = geompy.MakePrismVecH(geomObj_2362 , geomObj_2004 , 0.14)
geomObj_2364 = geompy.MakeCompound([geomObj_2319 , geomObj_2363])
geomObj_2365 = geompy.MakePlane(geomObj_2003 , geomObj_2004 , 2000)
geomObj_2366 = geompy.MakeMirrorByPlane(geomObj_2364 , geomObj_2365)
geomObj_2367 = geompy.MakeCompound([geomObj_2364 , geomObj_2366])
T_shape_fluid = geompy.MakeGlueFaces(geomObj_2367 , 1e-07)
[geomObj_2368] = geompy.SubShapes(T_shape_fluid , [514])
[geomObj_2369] = geompy.SubShapes(T_shape_fluid , [490])
[geomObj_2370] = geompy.SubShapes(T_shape_fluid , [376])
[geomObj_2371] = geompy.SubShapes(T_shape_fluid , [107])
[geomObj_2372] = geompy.SubShapes(T_shape_fluid , [242])
[geomObj_2373] = geompy.SubShapes(T_shape_fluid , [276])
[geomObj_2374] = geompy.SubShapes(T_shape_fluid , [241])
[geomObj_2375] = geompy.SubShapes(T_shape_fluid , [275])
[geomObj_2376] = geompy.SubShapes(T_shape_fluid , [327])
[geomObj_2377] = geompy.SubShapes(T_shape_fluid , [335])
[geomObj_2378] = geompy.SubShapes(T_shape_fluid , [342])
[geomObj_2379] = geompy.SubShapes(T_shape_fluid , [59])
[geomObj_2380] = geompy.SubShapes(T_shape_fluid , [66])
[geomObj_2381] = geompy.SubShapes(T_shape_fluid , [73])
[geomObj_2382] = geompy.SubShapes(T_shape_fluid , [51])
inlet_1 = geompy.CreateGroup(T_shape_fluid , geompy.ShapeType["FACE"])
geompy.UnionIDs(inlet_1 , [525 , 367 , 518 , 408 , 420 , 494 , 391 , 506])
Inlet_2 = geompy.CreateGroup(T_shape_fluid , geompy.ShapeType["FACE"])
geompy.UnionIDs(Inlet_2 , [204 , 461 , 449 , 432 , 163 , 473 , 187 , 216])
Outlet = geompy.CreateGroup(T_shape_fluid , geompy.ShapeType["FACE"])
geompy.UnionIDs(Outlet , [98 , 266 , 283 , 122 , 151 , 293 , 249 , 139])
groupe_h_mid = geompy.CreateGroup(T_shape_fluid , geompy.ShapeType["EDGE
    "])
geompy.UnionIDs(groupe_h_mid , [44 , 8 , 313 , 347 , 78 , 30 , 20 , 54 , 330 , 303 ,
    68 , 13])
groupe_cote = geompy.CreateGroup(T_shape_fluid , geompy.ShapeType["EDGE"])
geompy.UnionIDs(groupe_cote , [141 , 242 , 103 , 276 , 155 , 107 , 490 , 372 ,
    376 , 410 , 424 , 514 , 46 , 241 , 66 , 275 , 342 , 335 , 59 , 73 , 327 , 51 , 83 ,
    352])
groupe_petit_arc = geompy.CreateGroup(T_shape_fluid , geompy.ShapeType["
    EDGE"])
geompy.UnionIDs(groupe_petit_arc , [374 , 524 , 493 , 422 , 153 , 246 , 105 ,
    290 , 289 , 245 , 369 , 235 , 502 , 100 , 485 , 259 , 124 , 393 , 80 , 325 , 349 ,
    49 , 56 , 332 , 344 , 75 , 258 , 234 , 25 , 308 , 301 , 18 , 22 , 305 , 315 , 32])
groupe_grand_arc = geompy.CreateGroup(T_shape_fluid , geompy.ShapeType["
    EDGE"])
geompy.UnionIDs(groupe_grand_arc , [396 , 412 , 517 , 127 , 280 , 279 , 143 ,
    397 , 262 , 11 , 128 , 263 , 505 , 27 , 310 , 90 , 359 , 15 , 35 , 318 , 93 , 362])
groupe_proff_mid_hori_int = geompy.CreateGroup(T_shape_fluid , geompy.
    ShapeType["EDGE"])
geompy.UnionIDs(groupe_proff_mid_hori_int , [400 , 231 , 380 , 483 , 131 , 500 ,
    111 , 255 , 401 , 110 , 379 , 132])
groupe_proff_mid_hori_ext = geompy.CreateGroup(T_shape_fluid , geompy.
    ShapeType["EDGE"])
geompy.UnionIDs(groupe_proff_mid_hori_ext , [415 , 158 , 146 , 117 , 383 , 238 ,
    512 , 427 , 114 , 272 , 488 , 386])

```

```

groupe_proff_mid_verti_int = geompy.CreateGroup(T_shape_fluid , geompy.
    ShapeType["EDGE"])
geompy.UnionIDs(groupe_proff_mid_verti_int , [444, 176, 179, 175, 441,
    182])
groupe_proff_mid_verti_ext = geompy.CreateGroup(T_shape_fluid , geompy.
    ShapeType["EDGE"])
geompy.UnionIDs(groupe_proff_mid_verti_ext , [211, 197, 456, 196, 223,
    468])
geompy.DifferenceIDs(groupe_cote , [141, 242, 103, 276, 155, 107, 490,
    372, 376, 410, 424, 514, 46, 241, 66, 275, 342, 335, 59, 73, 327, 51,
    83, 352])
geompy.UnionIDs(groupe_cote , [141, 242, 103, 276, 155, 107, 490, 372,
    376, 410, 424, 514, 46, 241, 66, 275, 342, 335, 59, 73, 327, 51, 83,
    352, 192, 206, 453, 463])
geompy.DifferenceIDs(groupe_petit_arc , [374, 524, 493, 422, 153, 246,
    105, 290, 289, 245, 369, 235, 502, 100, 485, 259, 124, 393, 80, 325,
    349, 49, 56, 332, 344, 75, 258, 234, 25, 308, 301, 18, 22, 305, 315,
    32])
geompy.UnionIDs(groupe_petit_arc , [374, 524, 493, 422, 153, 246, 105,
    290, 289, 245, 369, 235, 502, 100, 485, 259, 124, 393, 80, 325, 349,
    49, 56, 332, 344, 75, 258, 234, 25, 308, 301, 18, 22, 305, 315, 32,
    189, 475, 220, 451])
geompy.DifferenceIDs(groupe_grand_arc , [396, 412, 517, 127, 280, 279,
    143, 397, 262, 11, 128, 263, 505, 27, 310, 90, 359, 15, 35, 318, 93,
    362])
geompy.UnionIDs(groupe_grand_arc , [396, 412, 517, 127, 280, 279, 143,
    397, 262, 11, 128, 263, 505, 27, 310, 90, 359, 15, 35, 318, 93, 362,
    165, 436, 465, 208, 170])
geompy.DifferenceIDs(groupe_petit_arc , [374, 524, 493, 422, 153, 246,
    105, 290, 289, 245, 369, 235, 502, 100, 485, 259, 124, 393, 80, 325,
    349, 49, 56, 332, 344, 75, 258, 234, 25, 308, 301, 18, 22, 305, 315,
    32, 189, 475, 220, 451])
geompy.UnionIDs(groupe_petit_arc , [374, 524, 493, 422, 153, 246, 105,
    290, 289, 245, 369, 235, 502, 100, 485, 259, 124, 393, 80, 325, 349,
    49, 56, 332, 344, 75, 258, 234, 25, 308, 301, 18, 22, 305, 315, 32,
    189, 475, 220, 451, 438, 434, 172, 168])
geompy.DifferenceIDs(groupe_cote , [141, 242, 103, 276, 155, 107, 490,
    372, 376, 410, 424, 514, 46, 241, 66, 275, 342, 335, 59, 73, 327, 51,
    83, 352, 192, 206, 453, 463])
geompy.UnionIDs(groupe_cote , [141, 242, 103, 276, 155, 107, 490, 372,
    376, 410, 424, 514, 46, 241, 66, 275, 342, 335, 59, 73, 327, 51, 83,
    352, 192, 206, 453, 463, 193, 218])
geompy.DifferenceIDs(groupe_cote , [141, 242, 103, 276, 155, 107, 490,
    372, 376, 410, 424, 514, 46, 241, 66, 275, 342, 335, 59, 73, 327, 51,
    83, 352, 192, 206, 453, 463, 193, 218])
geompy.UnionIDs(groupe_cote , [141, 242, 103, 276, 155, 107, 490, 372,
    376, 410, 424, 514, 46, 241, 66, 275, 342, 335, 59, 73, 327, 51, 83,
    352, 192, 206, 453, 463, 193, 218, 42, 70])
A = geompy.MakeVertex(-0.14, 0, 0)
B = geompy.MakeVertex(0.14, 0, 0)
C = geompy.MakeVertex(0, 0, 0.14)
AA = geompy.MakeVertex(-0.42, 0, 0)
BB = geompy.MakeVertex(3.08, 0, 0)
CC = geompy.MakeVertex(0, 0, 0.31)
proff_small = geompy.MakeLineTwoPnt(A, AA)

```

```

proff_long = geompy.MakeLineTwoPnt(B, BB)
proff_verti = geompy.MakeLineTwoPnt(C, CC)
wall_inlet_1 = geompy.CreateGroup(inlet_1 , geompy.ShapeType["EDGE"])
geompy.UnionIDs(wall_inlet_1 , [19, 28, 34, 38, 43, 7])
wall_inlet_2 = geompy.CreateGroup(Inlet_2 , geompy.ShapeType["EDGE"])
geompy.UnionIDs(wall_inlet_2 , [11, 21, 24, 42, 45, 48])
wall_outlet = geompy.CreateGroup(Outlet , geompy.ShapeType["EDGE"])
geompy.UnionIDs(wall_outlet , [27, 35, 42, 45, 48, 9])
wall = geompy.CreateGroup(T_shape_fluid , geompy.ShapeType["FACE"])
geompy.UnionIDs(wall , [224, 212, 194, 454, 469, 476, 416, 425, 384, 115,
    345, 328, 91, 76, 147, 360, 52, 287, 515, 522, 277, 243, 491, 156])
geompy.addToStudy( O , 'O' )
geompy.addToStudy( OX , 'OX' )
geompy.addToStudy( OY , 'OY' )
geompy.addToStudy( OZ , 'OZ' )
geompy.addToStudy( T_shape_fluid , 'T_shape_fluid' )
geompy.addToStudyInFather( T_shape_fluid , inlet_1 , 'inlet_1' )
geompy.addToStudyInFather( T_shape_fluid , Inlet_2 , 'Inlet_2' )
geompy.addToStudyInFather( T_shape_fluid , Outlet , 'Outlet' )
geompy.addToStudyInFather( T_shape_fluid , groupe_h_mid , 'groupe_h_mid' )
geompy.addToStudyInFather( T_shape_fluid , groupe_cote , 'groupe_cote' )
geompy.addToStudyInFather( T_shape_fluid , groupe_petit_arc , '
    groupe_petit_arc' )
geompy.addToStudyInFather( T_shape_fluid , groupe_grand_arc , '
    groupe_grand_arc' )
geompy.addToStudyInFather( T_shape_fluid , groupe_proff_mid_hori_int , '
    groupe_proff_mid_hori_int' )
geompy.addToStudyInFather( T_shape_fluid , groupe_proff_mid_hori_ext , '
    groupe_proff_mid_hori_ext' )
geompy.addToStudyInFather( T_shape_fluid , groupe_proff_mid_verti_int , '
    groupe_proff_mid_verti_int' )
geompy.addToStudyInFather( T_shape_fluid , groupe_proff_mid_verti_ext , '
    groupe_proff_mid_verti_ext' )
geompy.addToStudy( A , 'A' )
geompy.addToStudy( B , 'B' )
geompy.addToStudy( C , 'C' )
geompy.addToStudy( AA , 'AA' )
geompy.addToStudy( BB , 'BB' )
geompy.addToStudy( CC , 'CC' )
geompy.addToStudy( proff_smal , 'proff_smal' )
geompy.addToStudy( proff_long , 'proff_long' )
geompy.addToStudy( proff_verti , 'proff_verti' )
geompy.addToStudyInFather( inlet_1 , wall_inlet_1 , 'wall_inlet_1' )
geompy.addToStudyInFather( Inlet_2 , wall_inlet_2 , 'wall_inlet_2' )
geompy.addToStudyInFather( Outlet , wall_outlet , 'wall_outlet' )
geompy.addToStudyInFather( T_shape_fluid , wall , 'wall' )

###
### SMESH component
###

import SMESH, SALOMEDS
from salome.smesh import smeshBuilder

smesh = smeshBuilder.New()

```

EDF R&D	code_saturne version 8.0 tutorial: Turbulence simulation in a mixing tee	code_saturne documentation Page 107/127
---------	---	---

```

#smesh.SetEnablePublish( False ) # Set to False to avoid publish in study
if not needed or in some particular situations:
    # multiples meshes built in parallel,
    # complex and numerous mesh edition (
    # performance)

Mesh_1 = smesh.Mesh( T_shape_fluid )
Regular_1D = Mesh_1.Segment()
Number_of_Segments_1 = Regular_1D.NumberOfSegments(15)
Quadrangle_2D = Mesh_1.Quadrangle( algo=smeshBuilder.QUADRANGLE)
Hexa_3D = Mesh_1.Hexahedron( algo=smeshBuilder.Hexa)
Regular_1D_1 = Mesh_1.Segment(geom=groupe_proff_mid_hori_int)
Number_of_Segments_2 = Regular_1D_1.NumberOfSegments(28)
Regular_1D_2 = Mesh_1.Segment(geom=groupe_proff_mid_hori_ext)
status = Mesh_1.AddHypothesis( Number_of_Segments_2 ,
    groupe_proff_mid_hori_ext )
Regular_1D_3 = Mesh_1.Segment(geom=groupe_proff_mid_verti_int)
Number_of_Segments_3 = Regular_1D_3.NumberOfSegments(20)
Regular_1D_4 = Mesh_1.Segment(geom=groupe_proff_mid_verti_ext)
status = Mesh_1.AddHypothesis( Number_of_Segments_3 ,
    groupe_proff_mid_verti_ext )
Regular_1D_5 = Mesh_1.Segment(geom=groupe_grand_arc)
Number_of_Segments_4 = Regular_1D_5.NumberOfSegments(14)
Regular_1D_6 = Mesh_1.Segment(geom=groupe_petit_arc)
Number_of_Segments_5 = Regular_1D_6.NumberOfSegments(6)
Regular_1D_7 = Mesh_1.Segment(geom=groupe_h_mid)
Number_of_Segments_6 = Regular_1D_7.NumberOfSegments(7)
Regular_1D_8 = Mesh_1.Segment(geom=groupe_cote)
Number_of_Segments_7 = Regular_1D_8.NumberOfSegments(12,1.4,[ 490, 514,
    376, 335, 342, 241, 275, 66, 59, 51, 73, 70, 42, 327, 107, 242, 276 ])
isDone = Mesh_1.Compute()
Mesh_verti = smesh.Mesh( proff_verti )
Regular_1D_9 = Mesh_verti.Segment()
Number_of_Segments_8 = Regular_1D_9.NumberOfSegments(34)
isDone = Mesh_verti.Compute()
Mesh_long = smesh.Mesh( proff_long )
Regular_1D_10 = Mesh_long.Segment()
Fixed_Points_1 = Regular_1D_10.FixedPoints1D([ 0.0010204, 0.0023809 ],[
    1, 1, 586 ],[])
Fixed_Points_1.SetObjectEntry( "proff_long" )
Mesh_small = smesh.Mesh( proff_smal )
Regular_1D_11 = Mesh_small.Segment()
Fixed_Points_2 = Regular_1D_11.FixedPoints1D([ 0.010714, 0.025 ],[ 1, 1,
    54 ],[])
Fixed_Points_2.SetObjectEntry( "proff_smal" )
isDone = Mesh_long.Compute()
isDone = Mesh_small.Compute()
wall_inlet_1_1 = Mesh_1.GroupOnGeom( wall_inlet_1 , 'wall_inlet_1' ,SMESH.
    EDGE)
wall_inlet_2_1 = Mesh_1.GroupOnGeom( wall_inlet_2 , 'wall_inlet_2' ,SMESH.
    EDGE)
wall_outlet_1 = Mesh_1.GroupOnGeom( wall_outlet , 'wall_outlet' ,SMESH.EDGE)
inlet_1_1 = Mesh_1.GroupOnGeom( inlet_1 , 'inlet_1' ,SMESH.FACE)
Inlet_2_1 = Mesh_1.GroupOnGeom( Inlet_2 , 'Inlet_2' ,SMESH.FACE)
Outlet_1 = Mesh_1.GroupOnGeom( Outlet , 'Outlet' ,SMESH.FACE)

```

```

wall_1 = Mesh_1.GroupOnGeom(wall , 'wall' ,SMESH.FACE)
([ wall_inlet_1_extruded , wall_inlet_1_top , inlet_1_extruded , inlet_1_top
  ], error) = Mesh_1.ExtrusionAlongPathObjects( [], [], [ inlet_1_1 ],
  Mesh_small, None, 1, 0, [ ], 0, 0, [ 0, 0, 0 ], 1 )
([ wall_inlet_2_extruded , wall_inlet_2_top , Inlet_2_extruded , Inlet_2_top
  ], error) = Mesh_1.ExtrusionAlongPathObjects( [], [], [ Inlet_2_1 ],
  Mesh_verti, None, 1, 0, [ ], 0, 0, [ 0, 0, 0 ], 1 )
([ wall_outlet_extruded , wall_outlet_top , Outlet_extruded , Outlet_top ],
  error) = Mesh_1.ExtrusionAlongPathObjects( [], [], [ Outlet_1 ],
  Mesh_long, None, 1, 0, [ ], 0, 0, [ 0, 0, 0 ], 1 )
[ wall_inlet_1_1 , wall_inlet_2_1 , wall_outlet_1 , inlet_1_1 , Inlet_2_1 ,
  Outlet_1 , wall_1 , wall_inlet_1_extruded , wall_inlet_1_top ,
  inlet_1_extruded , inlet_1_top , wall_inlet_2_extruded , wall_inlet_2_top
  , Inlet_2_extruded , Inlet_2_top , wall_outlet_extruded , wall_outlet_top
  , Outlet_extruded , Outlet_top ] = Mesh_1.GetGroups()
Sub_mesh_1 = Regular_1D_1.GetSubMesh()
Sub_mesh_2 = Regular_1D_2.GetSubMesh()
Sub_mesh_3 = Regular_1D_3.GetSubMesh()
Sub_mesh_4 = Regular_1D_4.GetSubMesh()
Sub_mesh_5 = Regular_1D_5.GetSubMesh()
Sub_mesh_6 = Regular_1D_6.GetSubMesh()
Sub_mesh_7 = Regular_1D_7.GetSubMesh()
Sub_mesh_8 = Regular_1D_8.GetSubMesh()

### Set names of Mesh objects
smesh.SetName(Fixed_Points_1 , 'Fixed Points_1 ')
smesh.SetName(Fixed_Points_2 , 'Fixed Points_2 ')
smesh.SetName(Regular_1D.GetAlgorithm() , 'Regular_1D ')
smesh.SetName(Hexa_3D.GetAlgorithm() , 'Hexa_3D ')
smesh.SetName(Quadrangle_2D.GetAlgorithm() , 'Quadrangle_2D ')
smesh.SetName(Mesh_small.GetMesh() , 'Mesh_small ')
smesh.SetName(Mesh_long.GetMesh() , 'Mesh_long ')
smesh.SetName(Mesh_verti.GetMesh() , 'Mesh_verti ')
smesh.SetName(Mesh_1.GetMesh() , 'Mesh_1 ')
smesh.SetName(Inlet_2_extruded , 'Inlet_2_extruded ')
smesh.SetName(Outlet_extruded , 'Outlet_extruded ')
smesh.SetName(inlet_1_extruded , 'inlet_1_extruded ')
smesh.SetName(Outlet_top , 'Outlet_top ')
smesh.SetName(Sub_mesh_8 , 'Sub-mesh_8 ')
smesh.SetName(Sub_mesh_6 , 'Sub-mesh_6 ')
smesh.SetName(Sub_mesh_7 , 'Sub-mesh_7 ')
smesh.SetName(Sub_mesh_4 , 'Sub-mesh_4 ')
smesh.SetName(Sub_mesh_5 , 'Sub-mesh_5 ')
smesh.SetName(Sub_mesh_2 , 'Sub-mesh_2 ')
smesh.SetName(Sub_mesh_3 , 'Sub-mesh_3 ')
smesh.SetName(Sub_mesh_1 , 'Sub-mesh_1 ')
smesh.SetName(Number_of_Segments_4 , 'Number of Segments_4 ')
smesh.SetName(Number_of_Segments_3 , 'Number of Segments_3 ')
smesh.SetName(Number_of_Segments_2 , 'Number of Segments_2 ')
smesh.SetName(wall_outlet_extruded , 'wall_outlet_extruded ')
smesh.SetName(Number_of_Segments_1 , 'Number of Segments_1 ')
smesh.SetName(Inlet_2_top , 'Inlet_2_top ')
smesh.SetName(Number_of_Segments_8 , 'Number of Segments_8 ')
smesh.SetName(Number_of_Segments_7 , 'Number of Segments_7 ')

```

```
smesh.SetName(Number_of_Segments_6, 'Number of Segments_6')
smesh.SetName(wall_inlet_1_extruded, 'wall_inlet_1_extruded')
smesh.SetName(Number_of_Segments_5, 'Number of Segments_5')
smesh.SetName(wall_1, 'wall')
smesh.SetName(wall_inlet_2_extruded, 'wall_inlet_2_extruded')
smesh.SetName(inlet_1_top, 'inlet_1_top')
smesh.SetName(inlet_1_1, 'inlet_1')
smesh.SetName(Outlet_1, 'Outlet')
smesh.SetName(Inlet_2_1, 'Inlet_2')
smesh.SetName(wall_inlet_1_top, 'wall_inlet_1_top')
smesh.SetName(wall_inlet_2_top, 'wall_inlet_2_top')
smesh.SetName(wall_outlet_top, 'wall_outlet_top')
smesh.SetName(wall_inlet_1_1, 'wall_inlet_1')
smesh.SetName(wall_inlet_2_1, 'wall_inlet_2')
smesh.SetName(wall_outlet_1, 'wall_outlet')
```

```
if salome.sg.hasDesktop():
    salome.sg.updateObjBrowser()
```

3 Appendix C – Creating the Computational Domain

4 What you will learn

In this part of the tutorial you will use the geometry, GEOM, and meshing, MESH, modules of SALOME to create the computational domain. Through the different steps, you will learn to:

- Create a decomposition in blocks of the geometry in order to have a conformal hexahedral mesh by executing basic operations
- Create groups in order to prepare the meshing process and the setting-up of the boundary condition
- Specify different mesh sizes by applying different laws to mesh your domain.

You can skip this part and obtain the mesh with the groups by executing the script supplied in Appendix 2.

5 Creating the Geometry

The domain geometry is built in such a way that different meshes can be generated for RANS or LES calculations by modifying only the refinement parameters. A butterfly decomposition in 8 parts is used for the inlet and the outlet.

Only the T junction is created in this module (red part in Figure VII.1) the. The complete domain will be constructed in the MESH module.

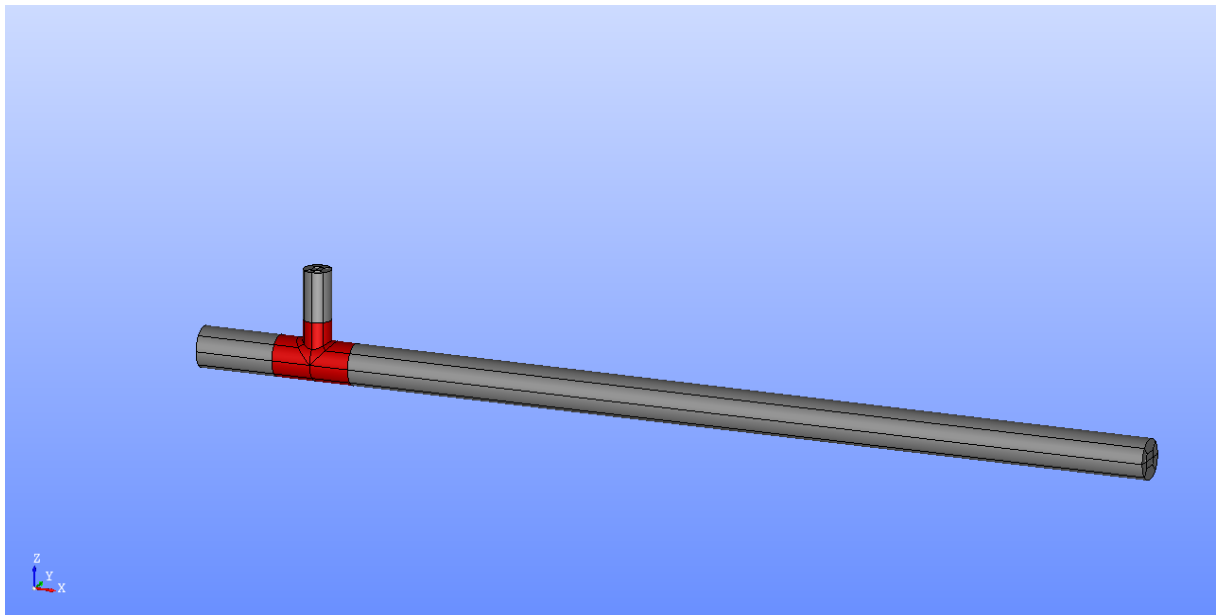

Figure VII.1: Geometry of the T junction pipe.

Go to the GEOM module of SALOME.

Click on *New Entity* ⇒ *Python Plugins* ⇒ *T shape fluid* as shown in Figure VII.2 below.

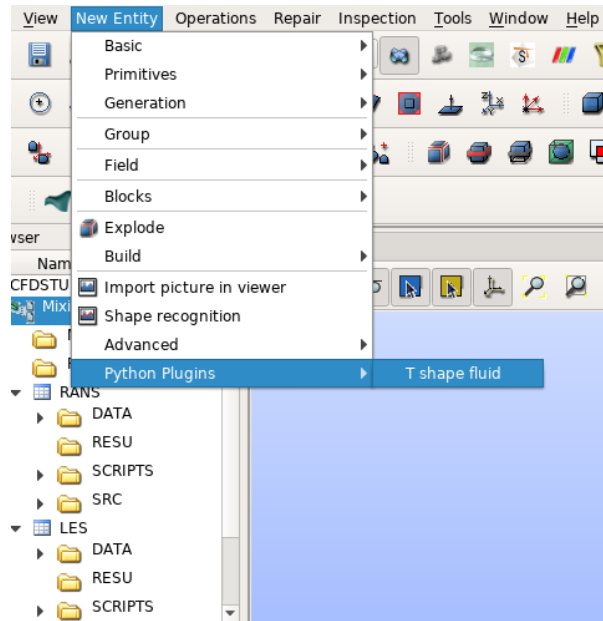

Figure VII.2: Creating T shape.

In the pop-up menu activated, the T junction's dimensions are specified according to the problem definition as shown in Figure VII.3.

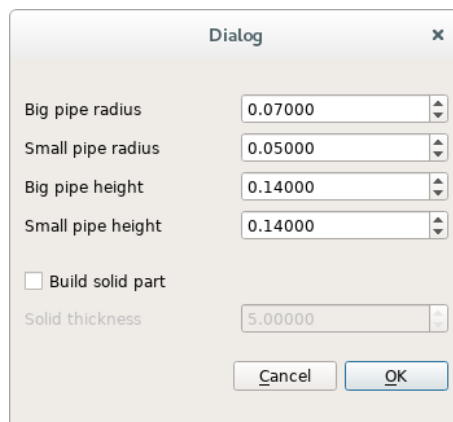

Figure VII.3: T shape definition menu.

You obtain the shape shown in Figure VII.4.

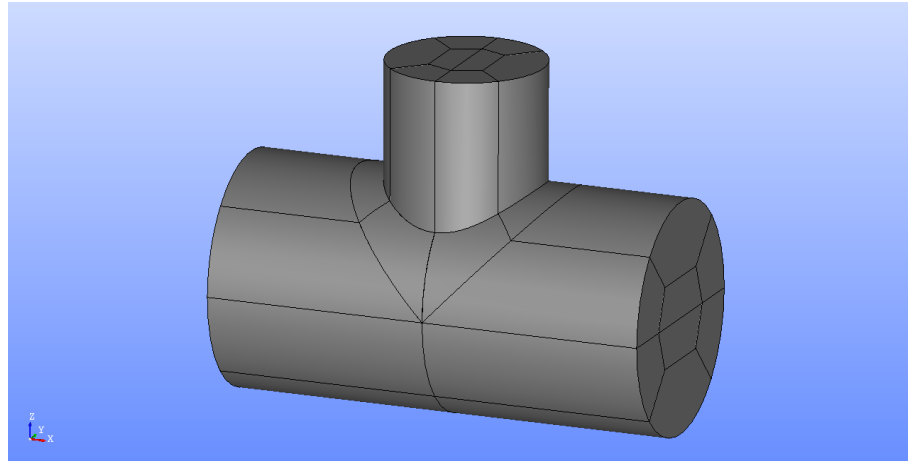

Figure VII.4: T junction visualisation.

Finally, create the following points:

Name:	Coordinates
A	x: -0.14; y: 0, z: 0
AA	x: -0.42; y: 0, z: 0
B	x: 0.14; y: 0, z: 0
BB	x: 3.08; y: 0, z: 0
C	x: 0; y: 0, z: 0.14
CC	x: 0; y: 0, z: 0.31

Table VII.10: Points coordinates.

and the following lines:

Name:	Point 1	Point 2
proff_small	A	AA
proff_long	B	BB
proff_verti	C	CC

Table VII.11: Lines definition.

6 Creating groups

6.1 Creating groups of faces

In order to set up the boundary conditions later, it is necessary to create several groups of faces.

To create a group of faces, right click on your geometry in "Object Browser" then click on "Create group".

In the "Create Group" pop-up window, select "faces" in "Shape type", name and select your faces for the horizontal pipe's inlet, *inlet_1*, Figure VII.5, the vertical pipe's inlet, *inlet_2*, Figure VII.6, the

horizontal pipe's outlet, *outlet*, Figure VII.7 and, lastly, the wall boundary, *wall*, Figure VII.8. To select several faces keep the shift key pressed.

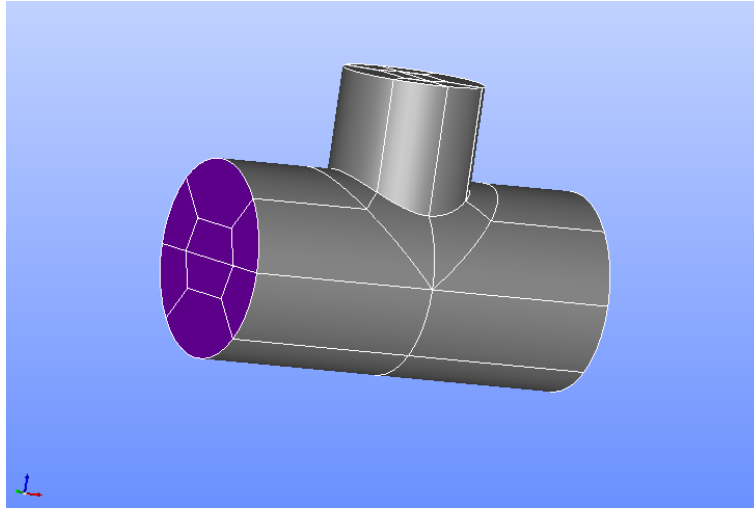

Figure VII.5: inlet_1.

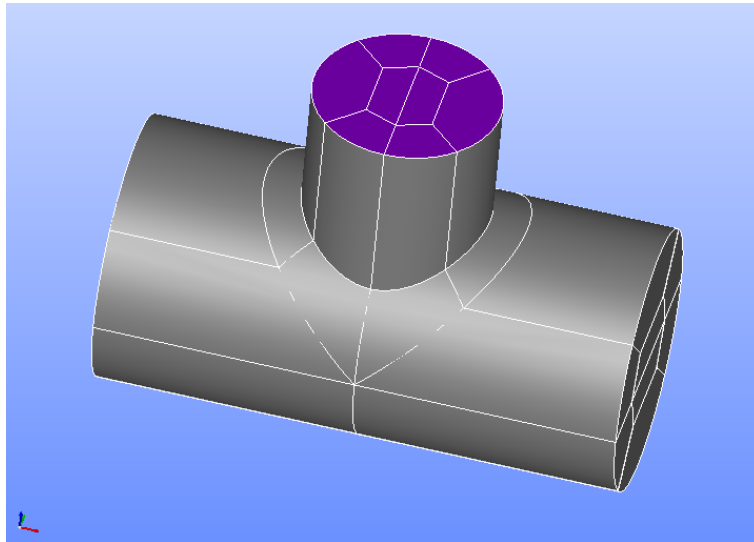

Figure VII.6: inlet_2

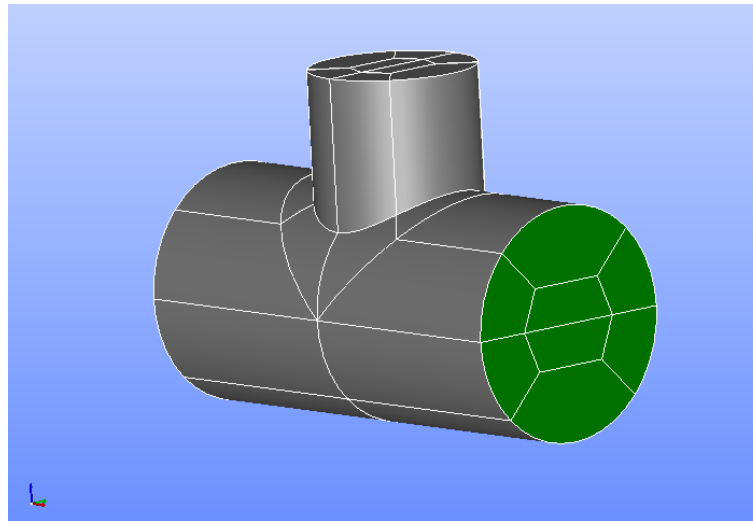

Figure VII.7: outlet.

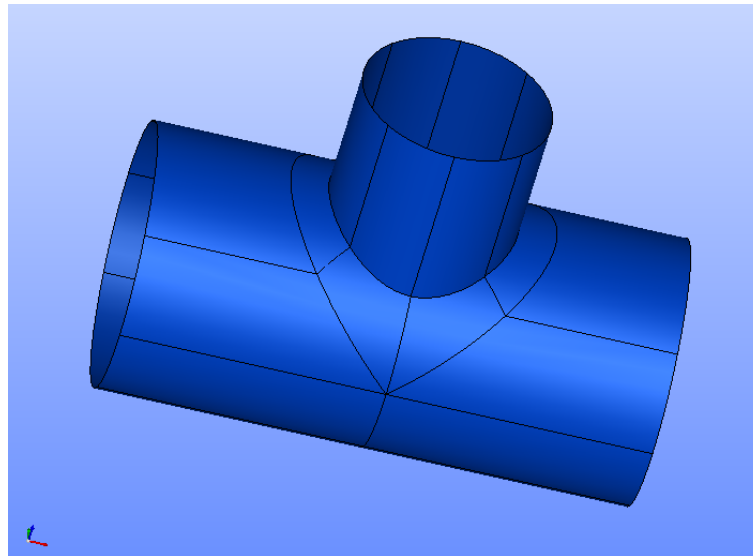
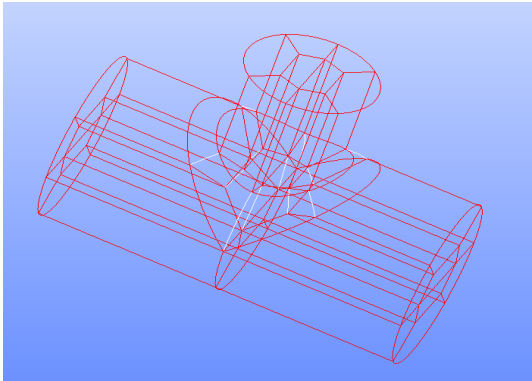

Figure VII.8: wall.

6.2 Creating group of edges

In order to mesh the computational domain easily it is necessary to create several groups of edges. To create a group of edges, right click on your geometry in "Object Browser" and then click on "Create group". A pop-up window called "Create Group" appears, select edges in "Shape type", name and select your groups as shown in Figure VII.9a to VII.9h. To select several edges keep the shift key pressed.



(a) groupe_h_mid

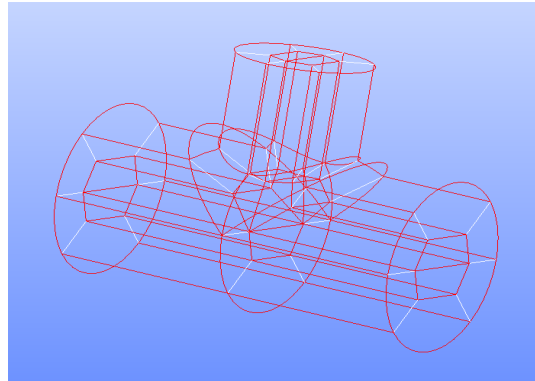

(b) groupe_cote

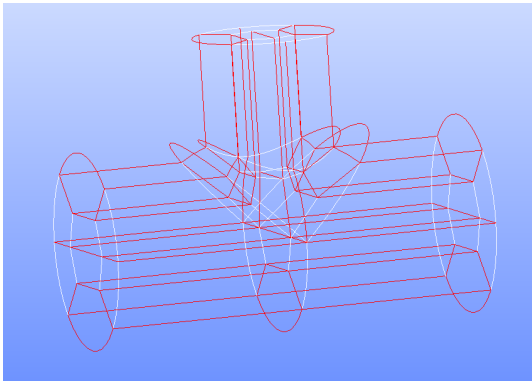

(c) groupe_petit_arc

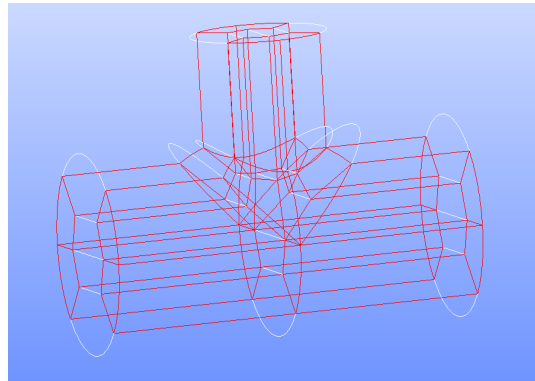

(d) groupe_grand_arc

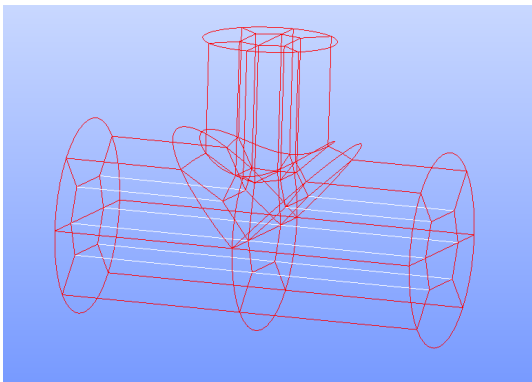

(e) groupe_proff_mid_hori_int

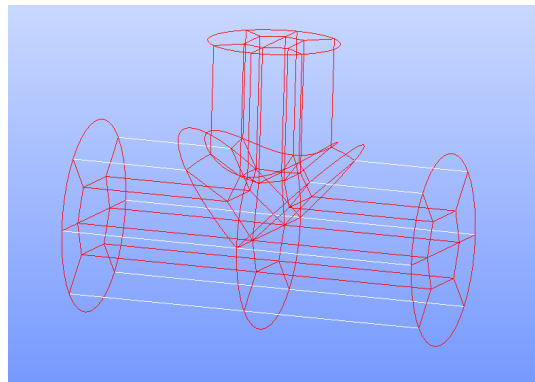

(f) groupe_proff_mid_hori_ext

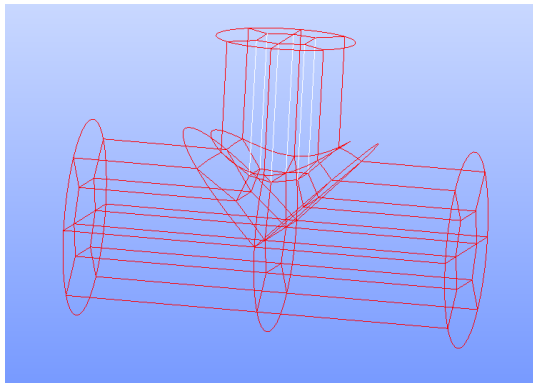

(g) groupe_proff_mid_verti_int

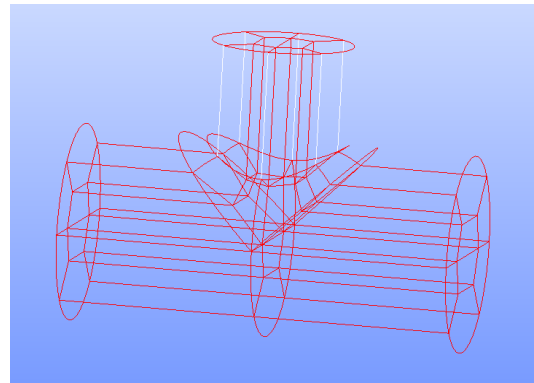

(h) groupe_proff_mid_verti_ext

Figure VII.9: Defining the groups of edges.

The last step is to create some groups that will be useful in creating the wall boundary of the complete domain.

Right click on the groupe of faces inlet_1 and select **Create Group**. Select the edges composing the border of the disk and add them to the group (Figure VII.10). It will be a part of our boundary condition "wall".

- **Shape Type:** edges
- **Group Name:** wall_inlet_1
- **Main Shape:** inlet_1
- **Main Shape Selection restriction:** No restriction

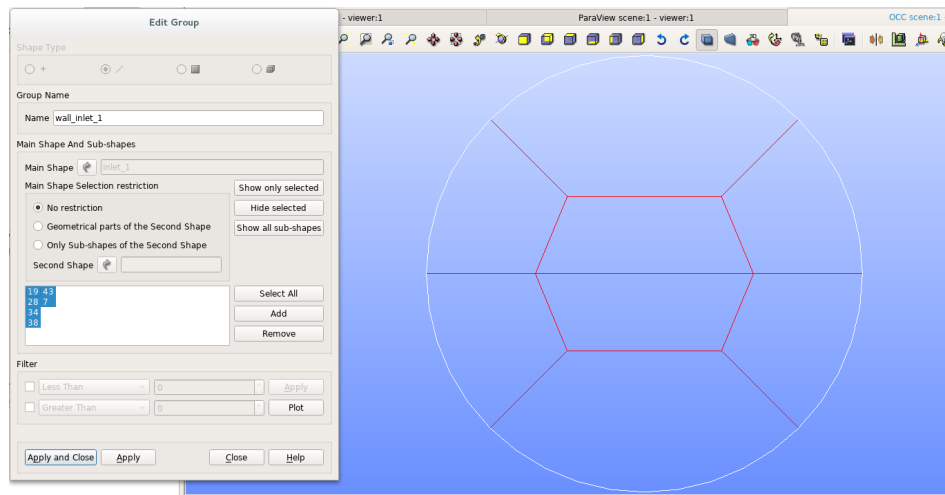

Figure VII.10: Creation of the group "wall_inlet_1"

Follow the same steps to create the groups wall_inlet_2 and wall_outlet from the border of inlet_2 and outlet groups of faces.

The geometry model is now ready to be meshed in the MESH module.

7 Meshing

Move to the MESH module of SALOME.

In order to keep a conform and hexahedral mesh, different sets of hypotheses are needed to discretise the different groups of edges.

First, create a mesh of your geometry: *Mesh* \Rightarrow *Create Mesh*. In the pop-up, click on "Assign a set of hypotheses" and choose "3D: Automatic Hexahedralization" as shown in Figure VII.11. Then, press "Apply and Close".

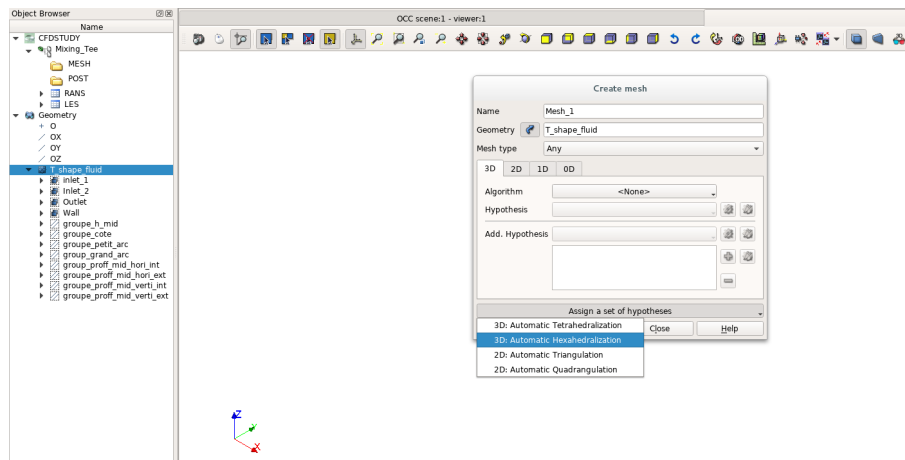

Figure VII.11: Selecting the hexahedral hypothesis.

The next step is to create a sub-mesh for each group of edges. Right click on your mesh previously created, called "Mesh_1" by default, and select "Create sub-mesh". Then select a group of edges by clicking on a group in the tree of the "Object Browser" as shown in Figure VII.12. Then select "Wire Discretisation" for the algorithm and select the hypothesis "Nb Segments" that you can rename. In Figure VII.12 is an example of how to proceed for the group of edges "proff_small_int".

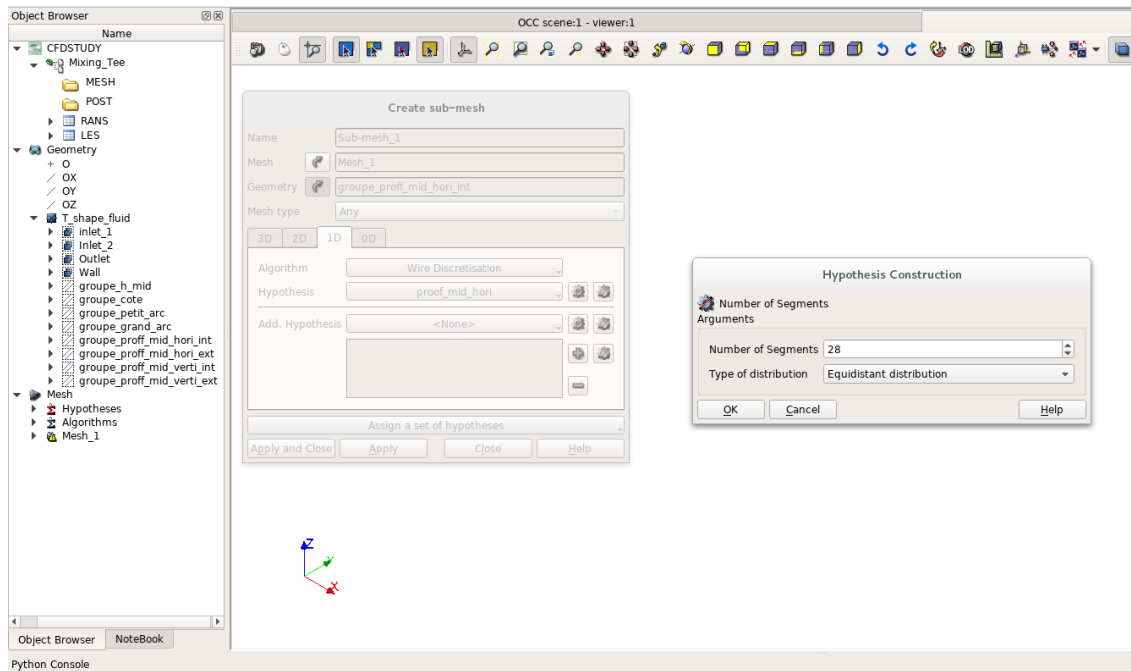

Figure VII.12: Creating a Sub-mesh for proff_small_int.

Repeat the same operation for the others groups of edges with the parameters given in Table VII.12.

Group	Hypothesis	Type of distribution	Nb. Segments
proff_mid_hori_int	Nb. Segments	Equidistant distribution	28
proff_mid_hori_ext	Nb. Segments	Equidistant distribution	28
proff_mid_verti_int	Nb. Segments	Equidistant distribution	20
proff_mid_verti_ext	Nb. Segments	Equidistant distribution	20
grand_arc	Nb. Segments	Equidistant distribution	14
petit_arc	Nb. Segments	Equidistant distribution	6
h_mid	Nb. Segments	Equidistant distribution	7

Table VII.12: Meshing parameters.

For the group named "cote" instead of selecting "Equidistant distribution" select "Scale distribution" and set a scale factor of 1.4 as shown in Figure VII.13. Check the orientation of every edges is going from the exterior to the interior of the pipe. Otherwise add the edges where the orientation is wrong in "Reversed Edges" field (see Figure VII.13).

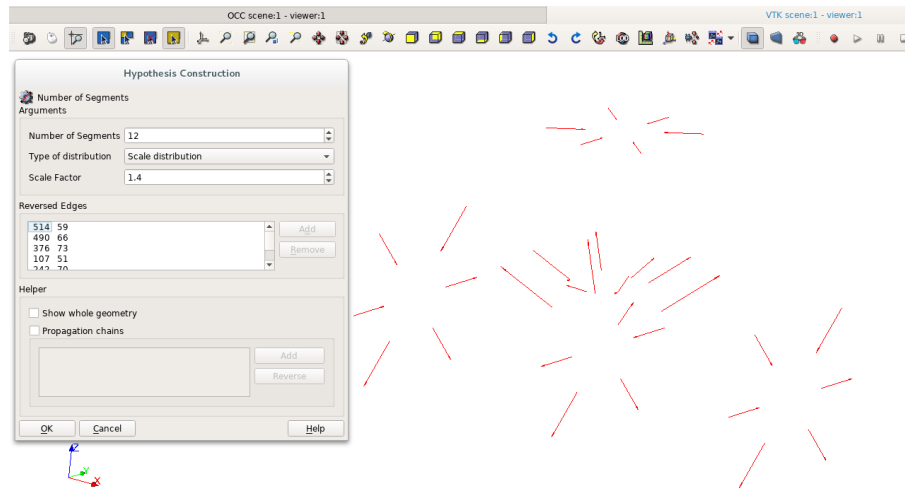

Figure VII.13: Scaling law and reversed edges.

You should have now a mesh with 8 sub-meshes. Right click on your mesh "Mesh_1" by default and select "compute". Your mesh will be created, if you right click on "Mesh_1" and select "Mesh information" you should have the same criteria as Figure VII.14.

Mesh Information				
Base Info	Element Info	Additional Info	Quality Info	
Name:	Mesh_1			
Object:	Mesh			
Nodes:	69186			
Elements:	<i>Total</i>	<i>Linear</i>	<i>Quadratic</i>	<i>Bi-Quadratic</i>
	87884	87884	0	0
0D:	0			
Balls:	0			
ID (edges):	2022	2022	0	
2D (faces):	20126	20126	0	
Triangles:	0	0	0	
Quadrangles:	20126	20126	0	
Polygons:	0	0	0	
3D (volumes):	65736	65736	0	
Tetrahedrons:	0	0	0	
Hexahedrons:	65736	65736	0	
Pyramids:	0	0	0	
Prisms:	0	0	0	0
Hexagonal Prisms:	0			
Polyhedrons:	0			

Figure VII.14: Mesh information.

The Figure [VII.15](#) is a view of the junction's mesh.

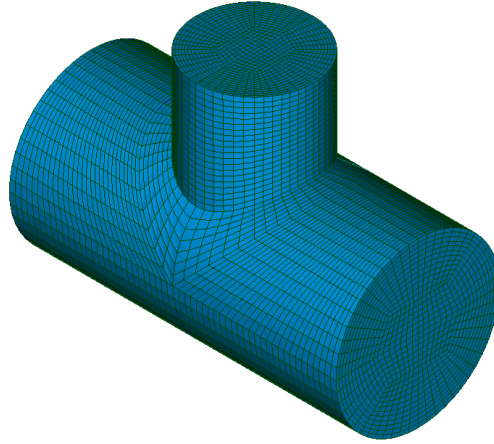

Figure VII.15: Junction between the cold and hot pipe.

In order to prepare the extrusion of the inlet disk, the best way is to mesh the three lines defined in the GEOM module and extrude the domain along these lines. The refinement of the lines mesh will be the final refinement of the domain in that directions.

Create a mesh for the line `proff_verti` with the parameters given in Table [VII.13](#) :

Group	Hypothesis	Type of distribution	Nb. Segments
<code>proff_verti</code>	Nb. Segments	Equidistant distribution	34

Table VII.13: Meshing parameters for line `proff_verti`.

For the last two lines set "Fixed Points 1D" for the hypothesis and set the parameters as shown in Figure [VII.16](#) and Figure [VII.17](#).

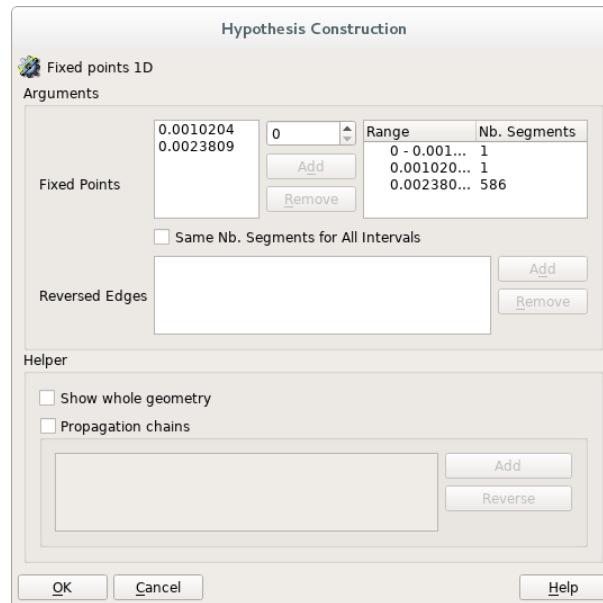

Figure VII.16: Fixed_Points_1d hypothesis for the line "proff.long".

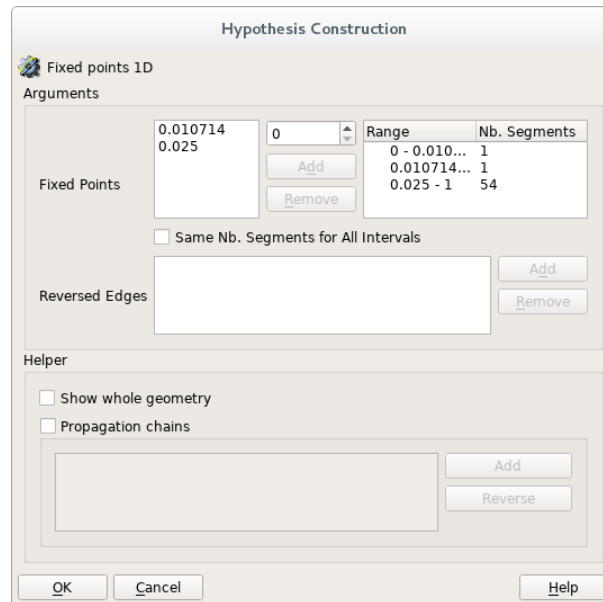

Figure VII.17: Fixed_Points_1d for the group "proff.small".

Compute all meshes by right clicking on each mesh and selecting "Compute".

7.1 Creating Groups in MESH

Right click on Mesh_1 and **Create Groups from Geometry**, then select the following groups : inlet_1, inlet_2, outlet, wall, wall_inlet_1, wall_inlet_2 and wall_outlet. Apply and close.



Figure VII.18: Creating groups from geometry.

Now the junction is well discretized and just needs to be extruded along each line.

7.2 Extrusion

For the first section, select *Modification* \Rightarrow *Extrusion along a path* and fill the pop-up window as follows:

Extrusion along a path

Extrusion

Nodes

Objects Set Filter

Select whole mesh, sub-mesh or group

Edges

Objects Set Filter

Select whole mesh, sub-mesh or group

Faces

Objects inlet_1 Set Filter

Select whole mesh, sub-mesh or group

Path

Mesh or sub-mesh Mesh_small

Start node 1

Base Point

X 0 Y 0 Z 0

Rotation Angles

45

Linear variation of the angles

Preview

Generate groups

Apply and Close Apply Close Help

Figure VII.19: Extrusion along proff_small

Select the group inlet_2 and extrude it along the mesh of proff_verti (Figure VII.20):

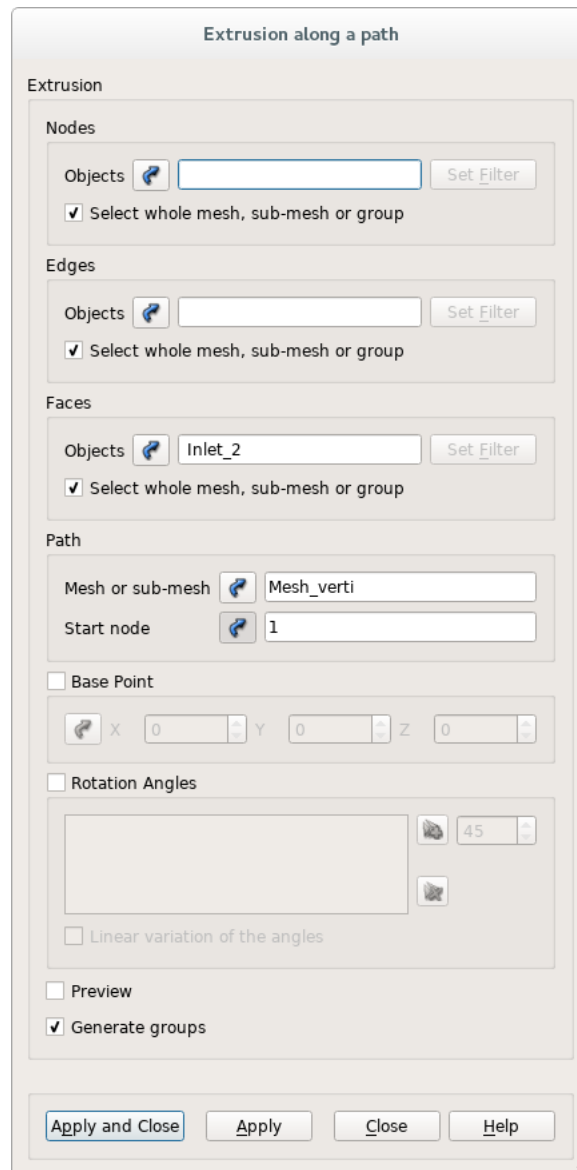

Figure VII.20: Extrusion along proff_verti

Finally, select the group outlet, and extrude it along the mesh of proff_log (Figure VII.20):

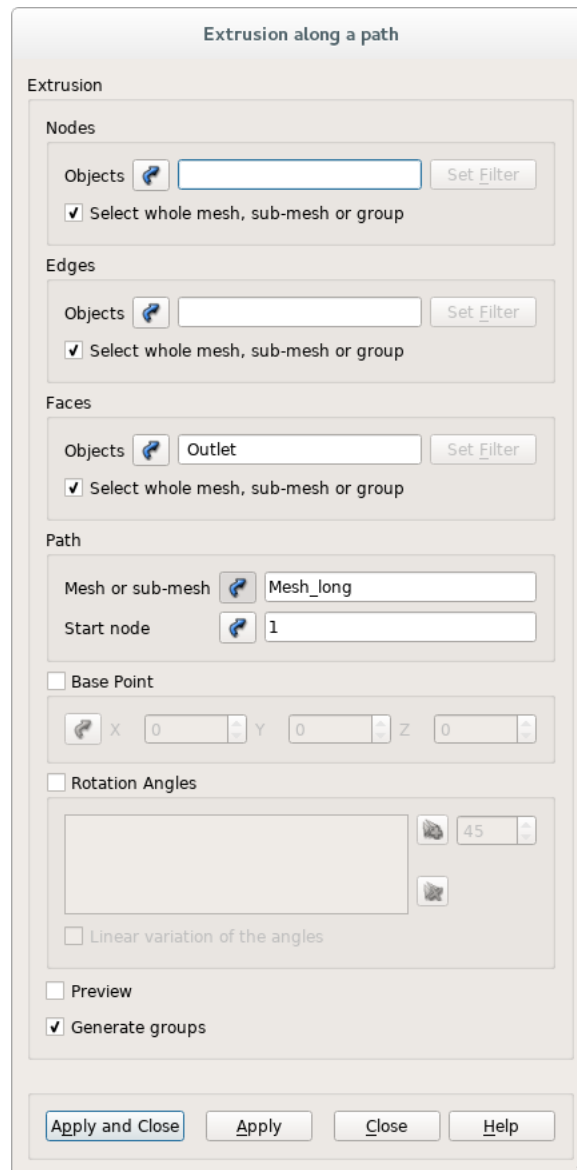

Figure VII.21: Extrusion along proff_log

Remove all groups of Groups of Edges. In Groups of Faces, select wall_inlet_1_extruded, wall_inlet_2_extruded, wall_outlet_extruded and Wall (with "Ctrl"), click on **Mesh** ⇒ **Union groups** and name it wall. Apply and close, then remove wall_inlet_1_extruded, wall_inlet_2_extruded, wall_outlet_extruded, Wall, Inlet_1, Inlet_2 and Outlet. Rename Inlet_1_top as inlet_1, Inlet_2_top as inlet_2 and Outlet_top as outlet. Finally, remove all groups of Groups of Volumes. You can also change the groups colors to be able to distinguish them clearly.

You should get a final mesh as shown on Figure VII.22 and Figure VII.23.

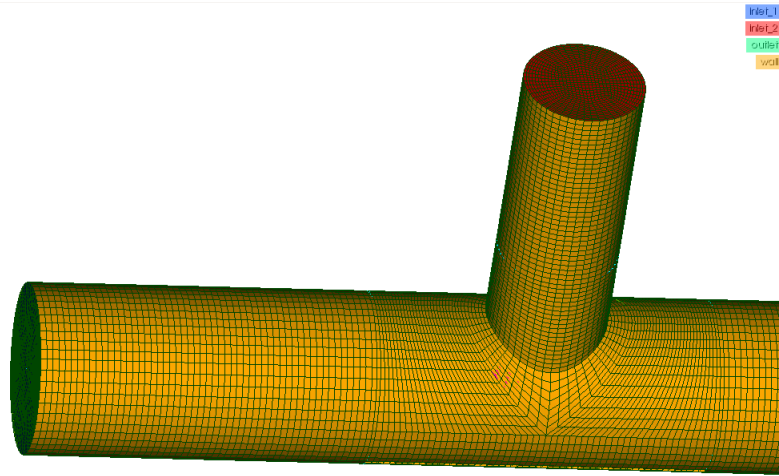

Figure VII.22: Zoom on final mesh

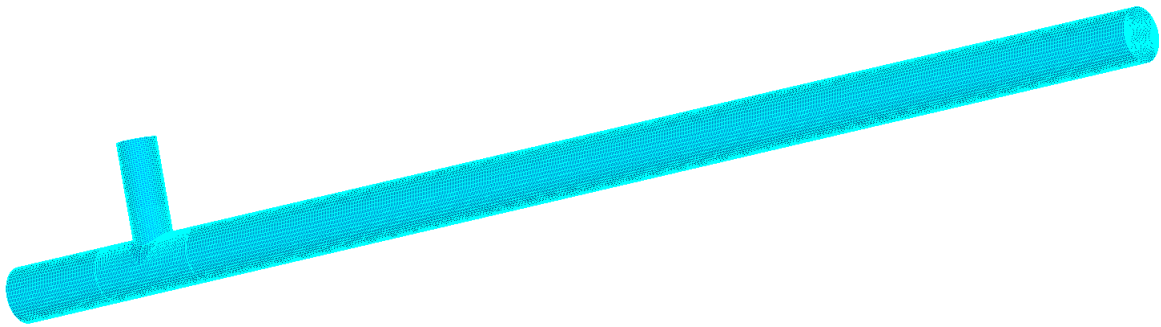

Figure VII.23: Final mesh

If you right click on "Mesh_1" and select "Mesh information" you should have now the same criteria as Figure VII.24.

Mesh Information

Base Info | Element Info | Additional Info | Quality Info

Name: Mesh_1

Object: Mesh

Nodes: 624468

Elements:	Total	Linear	Quadratic	Bi-Quadratic
	662648	662648	0	0

0D: 0

Balls: 0

1D (edges):	2178	2178	0
	2178	2178	0

2D (faces):	57758	57758	0	0
Triangles:	0	0	0	0
Quadrangles:	57758	57758	0	0
Polygons:	0	0	0	0

3D (volumes):	602712	602712	0	0
Tetrahedrons:	0	0	0	0
Hexahedrons:	602712	602712	0	0
Pyramids:	0	0	0	0
Prisms:	0	0	0	0
Hexagonal Prisms:	0	0	0	0
Polyhedrons:	0	0	0	0

Ok Dump Help

Figure VII.24: Final mesh information.

Save the SALOME file and export the mesh file in .med format by selecting from the main menu: **File** ⇒ **Export** ⇒ **MED file**. The file should be placed in the "MESH" directory of the T Junction study, where code_saturne will expect the file to be situated by default.

For the file name, choose "Mesh_RANS_1"; the .med extension is automatically added. You are now ready to set up the CFD simulation with the CFDStudy module.